



Installation and Test Guidelines

Generic Cabling



090.6323

One LAN for all needs – Your goal: A single structured solution that makes it easy to maintain your cabling infrastructure, whether your site is an office, building, apartment, a bigger installation like a hotel, recreational facility, social/ health care institution, factory – or even a ship.

Your partner? R&M, of course.

Our local area network (LAN) solutions provide planners, installers and users with end-to-end support for all their data network and communication infrastructure needs, whether these be future-proof design, trouble-free implementation or high-availability operation.

Our modular R&M*freenet* cabling system lets you configure a complete, quality solution, regardless of the size of your project or specific application, and also goes that extra step in user friendliness and ease of installation. All our products are application-neutral and have the ability to manage current and future transmission methods. R&M*freenet* was designed to be a best-in-class solution and thus surpasses all relevant standards.

Thanks to R&M's worldwide QPP Partner Program, certified partners receive priority support no matter where they are located, and in turn R&M, together with its partners, have the freedom to grant their end customers long-term system and application guarantees.



Data Center

High density, parallel optic connection technology translates into tremendous performance.



Public Networks

Marketable glass fiber solutions for implementing broadband infrastructures that will grow with the future.



Components

Pre-assembled units save time, while R&M's unique Security System optimizes availability.

Our Mission – We provide connectivity that matters

As an independent Swiss family business, Reichle & De-Massari AG (R&M), in Wetzikon (Zürich), has more than 50 years of experience in the information and communications technology market. Founded in 1964, R&M is now one of the leading providers of passive cabling solutions for high-quality communication networks (Layer 1). With its copper and fiber optic systems, the company makes a decisive contribution to operational reliability in voice, data and video transmission worldwide. As a system provider, R&M has set itself the goal of developing optimum functionality and above all fulfilling the highest quality criteria. R&M also offers maximum installation and maintenance convenience.

R&M solutions convince with maximum availability and cost-effective network operation. R&M's high product quality and forward-looking system design ensure that networks are future-proof and investments are secure in the long term. R&M cabling solutions are used in office buildings, data centers, by network operators, in homes and in industry. R&M helps people and organizations to communicate without restrictions. The company's drive and passion is to create a passive cabling infrastructure for end customers that guarantees maximum reliability and transmission security.

R&M (Reichle & De-Massari AG) is a leading global producer of future-proof products and systems for communication and data networks. The company's close collaboration with certified partners results in pioneering work in the sectors LAN, Public and Telecom Networks as well as Data Centers. The Swiss family company stands for innovation, quality, and customer orientation. Thanks to the innovative strength of the company, R&M now covers the entire connectivity range. For more information: www.rdm.com

Innovation

The innovative strength of the company is reflected in the R&D ratio. R&M invests over 5 percent of its annual sales in research and development. 23 percent of sales are generated with products that are less than three years old. The company holds over 100 international patents and participates in various international standards committees. The development work focuses on specific market and customer needs.



050.2205

It's in the production

The special experience and competence lies in the production of connection and distribution technology (connectivity) for copper and fiber optic networks. R&M offers solutions based on these technologies in its two business units Private Networks and Public Networks. Private networks offer structured cabling solutions for offices, data centers, industrial buildings and apartments. The focus here is on the highest transmission speeds and maximum network availability in the most diverse areas of application. The modular system supports high-speed network protocols up to 10 Gigabit Ethernet and more. The solutions for use in industrial buildings also meet the highest demands. The Cat. 6A as the top model of the FM45 family convinces with a compact housing and outstanding inner values. For the first time, a field-assembled RJ45 connector exceeds the requirements of ISO/IEC 11801-1 for category 6A. The FM45 Cat. 6A is suitable for the safe operation of 10 Gigabit Ethernet and also for the application of Power over Ethernet Plus (PoE+). Of course it is backwards compatible to Cat. 6 and Cat. 5e connections.

R&M's Netscale solutions are the optical fiber management solutions with the highest port density worldwide. These are the first solutions to feature integrated, intelligent infrastructure management. Designed as an ultra-high density platform, the system uses the thinnest Uniboot patch cords for minimal cabling space requirements and provides up to 67% higher density than previous solutions. It eliminates a multitude of cable management problems that today's data centers suffer from. With the Netscale patch cord, these problems are a thing of the past. It features an innovative push-pull mechanism with textured cap for easy access and removal of the connector. Polarity reversal without tools is also possible.

1,4 mm wins

Of particular interest is the industry-leading fiber cable diameter of 1.4 mm. Compared to conventional patch cords with a diameter of 2 mm or more, it offers unsurpassed convenience in high-density rack and panel configurations. Of course, the cables can be equipped with the R&M *IntelliPhy* RFID tag.

« The R&M team understands the customer's challenges and is entrusted to quickly develop uniquely designed and innovative products to meet the project objectives and delivery timelines. »







Mr. NR Patil, Assistant Vice President – Projects at Sterlite Power











&M

Table of Contents

	Installation and Test Guidelines	3
	Introduction	6
	Table of Contents	8
	Why R&Mfreenet	12
	1.1 Warranty	16
	1.1.1 Product certification	16
	1.1.2 QPP program	17
	2. Project quality assurance	18
	3. Pre-installation	22
	3.1 General	24
	3.1.1 Generic cabling standards	24
	3.1.2 MICE	27
	3.1.3 CPR Fire protection classes	28
	3.1.4 EMC concepts	32
	3.1.5 Infrastructure program	36
	3.2 Copper	37
	3.2.1 Copper standards	37
	3.2.2 Cable properties	40
	3.2.3 Channel restrictions for balanced cabling links	40
	3.2.4 Beyond the standard's length restrictions	48
	3.2.5 Coupler module Cat. 6 _A , cable coupler Cat.6 _A and connection kit RJ45	54
	3.2.6 Clearances between copper data and power cables	58
	3.2.7 Remote Powering – PoE, PoE+ and 4PPoE	62
	3.2.8 The importance of TCL test criteria for patch cords	68
	3.2.9 Screened vs unshielded	69
	3.2.10 Testing Class E _A Installation according ISO/IEC TR11801-9905	71
	3.2.9 Category 8	73
	3.3 Fiber	77
	3.3.1 Fiber standards	77
	3.3.2 Channel restrictions for fiber optic cable installations	91
	3.3.3 Creating a passive optical LAN network (POLAN)	93
	3.3.4 Planning the polarity of your fiber network	98

4. Installation	108
4.1 General	110
4.1.1 Safety	110
4.1.2 Labels and administration	110
4.1.3 Storage and transport of installation cable	111
4.1.4 Environmental conditions	112
4.2 Copper	114
4.2.1 Cable characteristics	114
4.2.2 Cable preparation	118
4.2.3 Termination of modules	119
4.2.4 Patch cables	120
4.2.5 Characteristic problems in generic cabling systems	120
4.3 Fiber	122
4.3.1 Safety	122
4.3.2 Cable installation	127
4.3.3 Cable preparation	129
4.3.4 Fiber cable termination	130
4.3.5 Patch cables	132
4.4 Installation checklist	133
5. Post-installation	134
5.1 General	136
5.1.1 Measurement accuracy	136
5.2 Copper	138
5.2.1 Approved certification test equipment for class D/E/E _A /Class I	138
5.2.2 Appropriate test adapter for class D/E/E _A /Class I	139
5.2.3 Test link configurations	141
5.2.4 Measurement Analysis	143

Table of Contents

	5.3 Fiber	145
	5.3.1 Approved certification test equipment for fiber	145
	5.3.2 Test link configurations	147
	5.3.3 Inspection and cleaning	150
	5.3.4 FO test conditions	153
	5.3.5 LSPM testing	156
	5.3.6 OTDR testing	162
	5.3.7 Documentation of fiber optic measurements	172
	6. Glossary	174
	7. Abbreviations	182
	8. Picture Key	186
	9. List of Tables	190
	10. List of Figures	194
	11. Notes	200



About the installation and test guidelines

These guidelines are an integral part of the R&M*freenet* warranty program. They are designed to take account of the increased complexity of acceptance tests and simplify field measurements in R&M*freenet* systems.

They are also intended to help installers, project managers and planners set up standards-compliant, highly reliable and extremely powerful passive networks. This document has been prepared with the greatest possible care. It contains the current technical status at the time of going to press.

Changes or corrections to this document will be taken into account in the new edition. Subject to technical changes and errors at any time There are some massive changes listed from the previous edition and we recommend the reader to read through all changed chapters in order to choose the correct procedure for a warranty installation.

Please check regularly at www.rdm.com to ensure you have the latest version.

Why R&Mfreenet

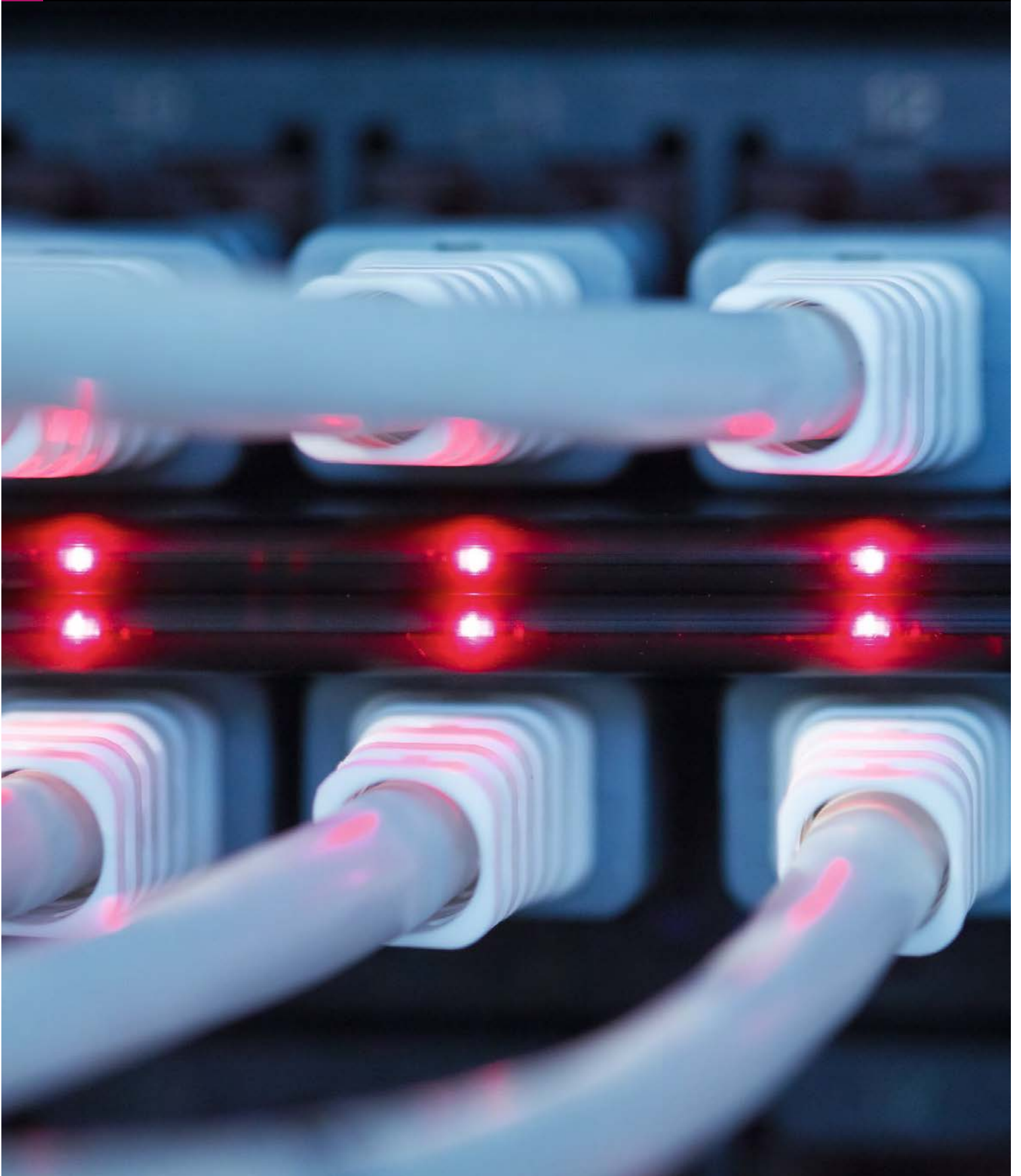

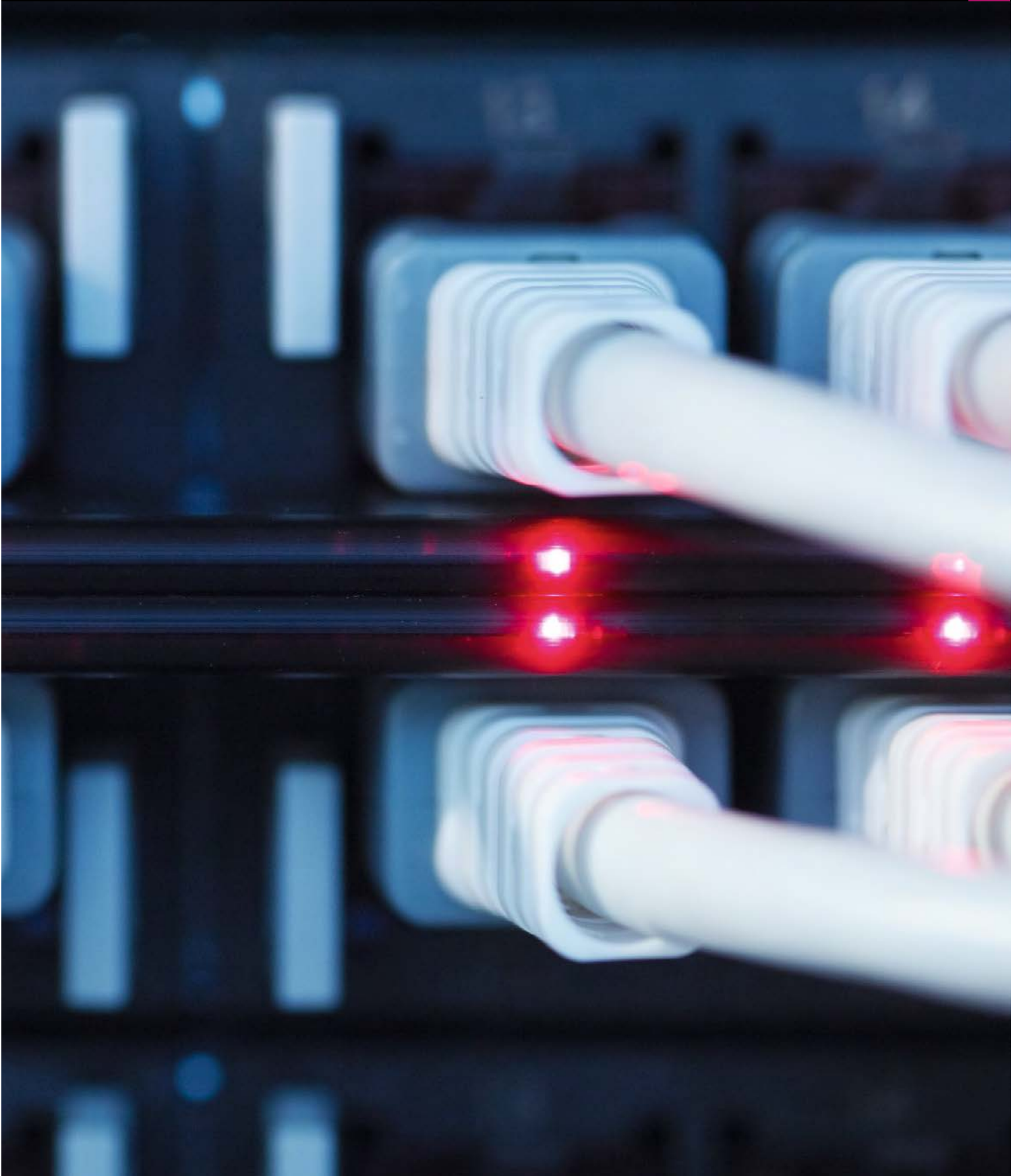

Powerful and reliable communication networks are crucial success factors for our customers.

Endless and absolutely logical

For planners and installers, the R&Mfreenet cabling system opens up a universe of infinite possibilities and a convincingly logical structure. With the systems for copper and fiber optics we can cover each and every cabling demand of our customers – be it for office premises, buildings, industrial plants, company locations, medical surroundings or high-performance data centers. On the base of the required performance capacity of the IT and telecommunications infrastructure, the environmental conditions and the required level of security, the ideal solution is configured from these systems. The modular principle and the standards-compliant, application-neutral

design guarantees that every installation can be used flexibly and extended in the future. The product ranges are consistently interoperable and based on the latest and relevant international standards series ISO/IEC 11801, EN 50173 and EIA/TIA 568.

Powerful and reliable communication networks are crucial success factors for our customers. They expect infrastructure investments to have a positive influence on their results - through higher productivity, reduced downtime costs or lower maintenance costs; that's why we do everything we can to make our customers successful.



Quality

It takes consistent Quality Management to guarantee the steady improvement of products, service and processes. That's how R&M partners worldwide are able to benefit from the consistent high Swiss quality standard. Our quality philosophy is reflected in recognized certifications such as EN ISO 9001:2008.



Continuity and Customer Orientation

As an independent family-owned company, R&M pursues a corporate strategy based on sustainability and involving all stakeholders. The company is wholly owned by the Reichle family. Since its founding in 1964, R&M has focused on passive cabling solutions - the reliable foundation of all communication networks. Martin and Peter Reichle represent the owner family in the second generation as active board members in all relevant committees. Our decisions are not subject to short-term profit considerations, but rather focus on long-term corporate development. This way our customers always know where they stand. Short decision paths and a collegial, team-oriented way of working encourage self-responsibility and initiative. The employees are characterized by a sense of responsibility and customer orientation.

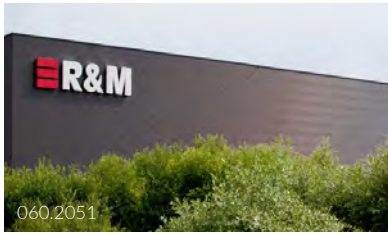

Environment

We strive to minimize the impact of our company's activities on the environment through careful management of resources. We set concrete objectives to ensure a sustainable approach. R&M's environmental commitment is in accordance with applicable laws and standards. The company is certified according to ISO 14001:2004.



Innovation

Research & Development is of great importance to R&M. For over 50 years we have been developing technological excellence in high-frequency technology and fiber optics. We are actively involved in the drafting of many international standards and recognize trends early on. The close proximity to our partners allows us to develop needed, innovative products. This means that our customers benefit from farsighted solutions that are also ideally suited to deal with future challenges and to protect their investments.



Reliability

Our products and services are aimed at ensuring a high level of network stability and availability. We achieve this through unrivalled product quality. This guarantees longevity and high performance. We also provide on-site support to planners, installers and end customers during the phase of solution design, as well as advice in the choice of systems; on request we also follow projects right through to commissioning.



Flexibility

Special tasks call for special solutions. In such cases, we team up with our customers to develop customized products or special service packages. With our international organization, we are big enough to be able to deliver this level of flexibility on site, wherever you are. Yet we are also small and dynamic enough to respond swiftly to our customers' wishes.

1. Why R&Mfreenet

1.1 Warranty

R&M offers one of the most comprehensive warranty programs in structured cabling in accordance with EN 50173, ISO/IEC 11801 and TIA 568. We do more than develop and manufacture products and systems of the highest quality. Our aim is to provide the customer with a solution that offers a high level of sustained performance. The warranty program comprises all the key elements needed for that solution: planning, product selection, installation, acceptance measurements and operational maintenance. In this way we achieve a homogeneous solution with a defined quality level.

With our three-level warranty program R&M guarantees its customers the faultless functioning of the R&M cabling system. The warranty is provided by certified partners who have completed the Qualified Partner Program (QPP).

5-year R&Mfreenet product warranty

This guarantees that R&Mfreenet passive components function faultlessly throughout the warranty period and exceed the requirements stipulated by each relevant cabling standard. This warranty cover is available to any customer who acquires R&Mfreenet passive components.

25-year R&Mfreenet system warranty

Covers the entire R&Mfreenet cabling system and protects the customer in the event of component malfunction and installation problems. The warranty applies if the installation consists exclusively of R&Mfreenet passive components and the entire installation was performed by an R&Mfreenet certified installation manager (or a higher instance trained by QPP).

Lifetime R&Mfreenet application warranty

This warranty is subject to the requirement that the installation with passive components from the R&Mfreenet cabling system was planned by a certified designer. It includes the commitment that all the protocols supported by industry standards are running on the system throughout its service life, plus any new applications that are retrospectively included into the Category or Class of system.

R&M have numerous products and systems proven and certified by multiple independent test laboratories. Our 3rd party certificates can be found online at www.rdm.com

1.1.1 Product certification

Structured IT cabling is the backbone of any network infrastructure. Malfunctions and failures quickly have considerable cost consequences. High network availability is therefore of fundamental importance.

In the context of «KonTraG», «Basel II» or «Solvency II», the responsibility of network operators is also increasingly demanded by law. Increasingly, customers rely on independent product evaluations by highly qualified and independent laboratories.

1.1.2 QPP program

Competent with QPP. The Qualified Partner Program for installers, planners and users of R&M*freenet* components.

R&M supports and encourages professionals in network technology and structured cabling with its Qualified Partner Program. You will increase your expertise and the quality of your projects. And you will gain satisfied customers. As a QPP partner, you will be part of the R&M family. The global network of certified R&M partners that:

- gives customers competent, professional advice on site
- always provides the ideal cabling solution pursuant to ISO/IEC 11801, EN 50173 or TIA 568
- has a compelling and unique Warranty Program, covering 5 years product, 25 years System and lifelong application warranty
- provides an ID card along with a certificate and unrestricted permission to install R&M*freenet*

With the QPP, R&M assures multinational customers the same high quality standard worldwide.

QPP Qualified Partner Program

R&M*freenet*

LAN Designer

DC Designer



**Lifetime
Warranty**

LAN Installation Manager



**25 Years
Warranty**

Copper Installer

Fiber Optics Installer

Sales & Support Specialist



**5 Years
Warranty**

2. Project quality assurance





2. Project quality assurance

Process	Objective	Responsible party
Planning	<ul style="list-style-type: none"> The generic cabling system must be carefully designed to comply with the current applicable standards Use new, approved/selected/suitable components The building infrastructure must be designed so that the generic cabling system can be installed in accordance with current applicable standards The planner is required to ensure that this occurs by preparing a cabling specification which is agreed upon by the architect/end user/installer Make sure that all needed tools are available Make sure the proper test procedures and equipment is defined Make sure all safety precautions are defined and the relevant personnel instructed 	Planner/architect end-customer
Component manufacturing	<ul style="list-style-type: none"> Materials used must be in accordance with the standards defined by the planner Components used must adhere to international and local regulations 	Component manufacturer
Installation	<ul style="list-style-type: none"> Components must be procured, stored, delivered and installed in accordance with the operating instructions Components must undergo receiving inspection Installation cables must be of the same or higher category as the connecting hardware Install in accordance with standard Make sure the cable duct is adequately protected to avoid damage from third parties Inspect the building infrastructure before installing. E.g. large enough cable routes, separation of data and power cables, large enough risers etc. Check labels Inspect the cabling installation frequently for proper workmanship (maintained bending radii, no kinks in the cables, periodic measurements etc.) Locate/remove or provide solutions for critical obstacles for pulling installation cables Provide adequate personnel (skill and number) for the project size Provide all adequate tools 	Installer

Project Quality Assurance, part 1

Process	Objective	Responsible party
Acceptance	<ul style="list-style-type: none"> • Periodic tests during the installation and before project completion according to agreed schedule (with end user) • Test in accordance with the instructions from the system supplier, the test equipment manufacturer and planner procedure • Make sure that the test equipment is adequate and in good working order • Ensure test equipment for both fiber and copper systems is calibrated in accordance with manufacturer specification (typically once per year) • Ensure also that test heads for modular equipment are calibrated in accordance with manufacturer specification (typically once per year) 	Installer, test company
Operation	<ul style="list-style-type: none"> • Ensure efficient system capacity utilization • Use the cabling in accordance with the specifications • Make sure the maintenance plan covers repair action procedures 	Building operator

Project Quality Assurance, part 2

3. Pre-installation

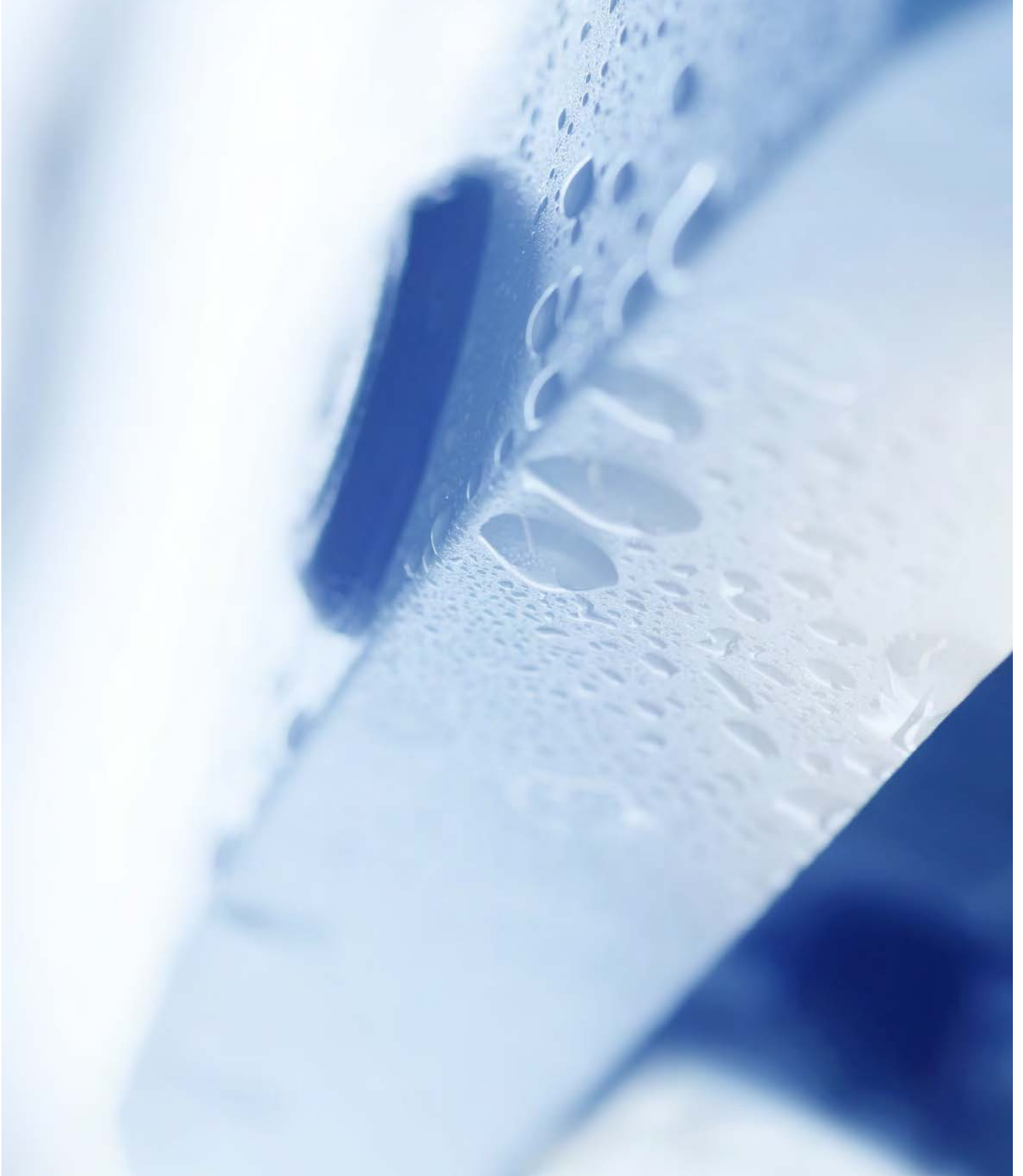

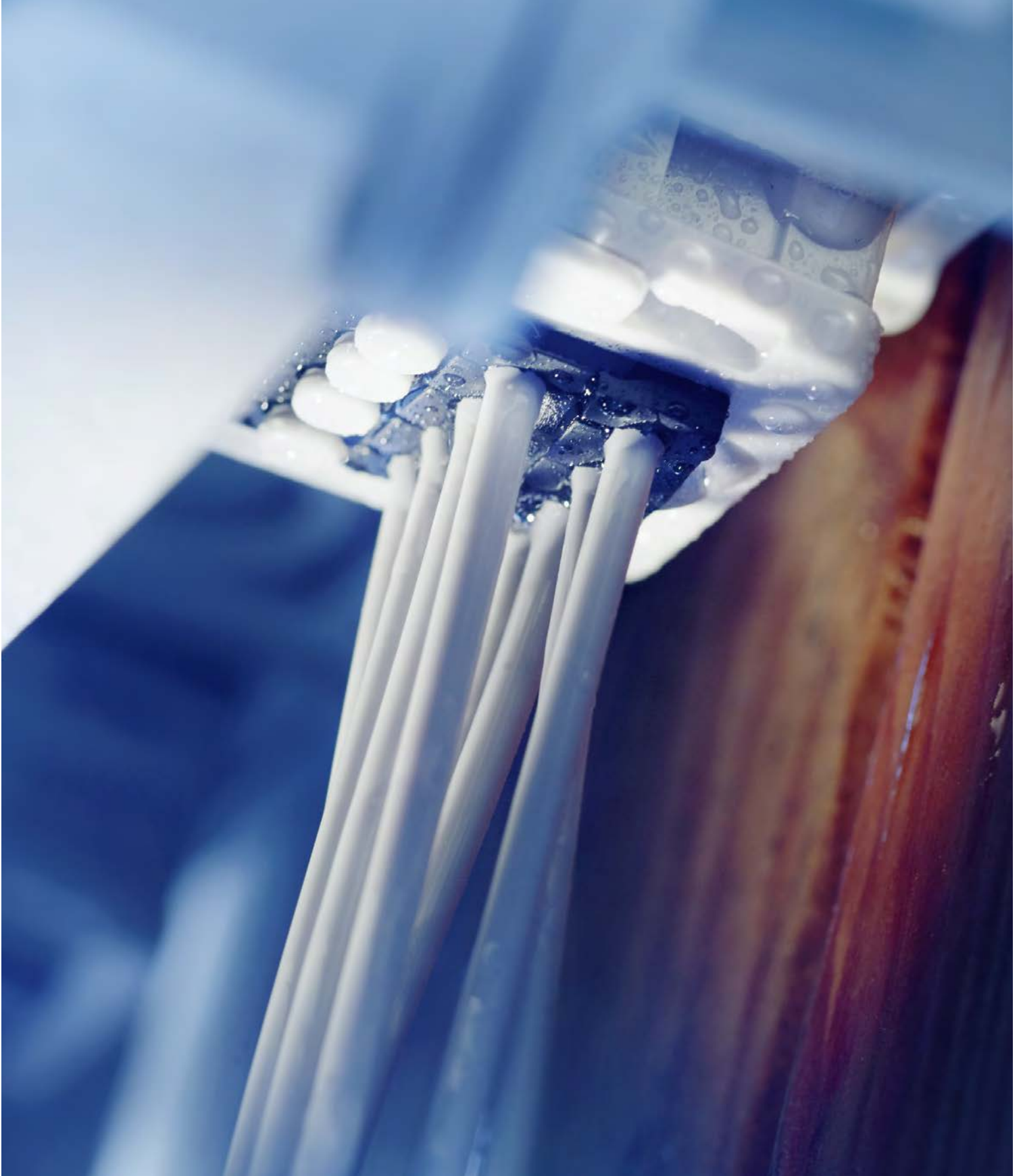

3. Pre-installation

3.1 General

3.1.1 Generic cabling standards

The following lists the current standards in the field of cabling and their status. Where uncertainties or contradictions exist, R&M uses ISO/IEC 11801 as a reference standard. The current valid edition can be found in «Appendix 1 to the Warranty Program» found at www.rdm.com.

ISO Standard	Description	Notes
ISO/IEC 11801-1: 2017	Information technology – Generic cabling for customer premises Part 1: General requirements	Ratified
ISO/IEC 11801-2: 2017	Information technology – Generic cabling for customer premises Part 2: Office premises	Ratified
ISO/IEC 11801-3: 2017	Information technology – Generic cabling for customer premises Part 3: Industrial premises	Ratified
ISO/IEC 11801-4: 2017	Information technology – Generic cabling for customer premises Part 4: Single-tenant homes	Ratified
ISO/IEC 11801-5: 2017	Information technology – Generic cabling for customer premises Part 5: Data Centers	Ratified
ISO/IEC 11801-6: 2017	Information technology – Generic cabling for customer premises Part 2: Distributed building services	Ratified
ISO/IEC 14763-2 Ed 2.0 2019	Information technology – Implementation and operation of customer premises cabling Part 2: Planning and installation	Ratified
ISO/IEC 14763-3:2014/A1:2018	Information technology – Implementation and operation of customer premises cabling Part 3: Testing of optical fiber cabling	Ratified
ISO/IEC 30129: 2015/A1:2019	Information technology – Telecommunications bonding networks for buildings and other structures	Ratified

ISO Standard

TIA Standard	Description	Notes
TIA-607-D: 2019	Generic Telecommunications Bonding and Grounding (Earthing) for Customer Premises	Ratified
TIA-568.0-D: 2015/A1:2017	Generic Telecommunications Cabling for Customer Premises	Ratified
TIA-568.1-E:2020	Commercial Building Telecommunications Infrastructure Standard	Ratified
TIA-568.2-D: 2018/A1:2019	Balanced Twisted-Pair Telecommunication Cabling and Components Standard	Ratified
TIA-568.3-D: 2016/A1:2019	Optical Fiber Cabling Components Standard	Ratified
TIA-942-B: 2017	Telecommunications Infrastructure Standard for Data Centers	Ratified

TIA Standard

TIA Standard

3. Pre-installation

EN Standard	Description	Notes
EN 50173-1: 2018	Information technology – Generic cabling systems Part 1: General requirements	Ratified
EN 50173-2: 2018	Information technology – Generic cabling systems Part 2: Office premises	Ratified
EN 50173-3: 2018	Information technology – Generic cabling systems Part 3: Industrial premises	Ratified
EN 50173-4: 2018	Information technology – Generic cabling systems Part 4: Homes	Ratified
EN 50173-5: 2018	Information technology – Generic cabling systems Part 5: Data centers	Ratified
EN 50173-6: 2018	Information technology – Generic cabling systems Part 6: Distributed building services	Ratified
EN 50174-1: 2018	Information technology – Cabling installation Part 1: Installation specification and quality assurance	Ratified
EN 50600-1: 2019	Information technology – Data center facilities and infrastructures Part 1: General concepts	Ratified
EN 50600-2-1: 2020	Information technology – Data center facilities and infrastructures Part 2-1: Building construction	Approval pending
EN 50600-2-2: 2019	Information technology – Data center facilities and infrastructures Part 2-2: Power distribution	Ratified
EN 50600-2-3: 2019	Information technology – Data center facilities and infrastructures Part 2-3: Environmental control	Ratified
EN 50600-2-4: 2015	Information technology – Data center facilities and infrastructures Part 2-4: Telecommunications Cabling Infrastructure	New version underway
EN 50600-2-5: 2016	Information technology – Data center facilities and infrastructures Part 2-5: Security systems	Ratified
EN 50600-3-1: 2016	Information technology – Data center facilities and infrastructures Part 2-6: Management and operational information	Ratified
EN 50174-2: 2018	Information technology – Data center facilities and infrastructures Part 2-6: Management and operational information	Ratified
EN 50174-3: 2013/A1:2018	Information technology – Cabling installation Part 3: Installation planning and practices outside buildings	Ratified
EN 50310: 2016	Telecommunications bonding networks for buildings and other structures	Ratified

EN Standard

3.1.2 MICE

To allow planning and cabling in a standardized and economical fashion within a varied range of environments, the ISO/IEC standardization committees developed the MICE concept. The so-called MICE matrix is the main item of this concept that provides planners with an easily manageable method for the description of environmental cabling conditions.

The matrix, based on the latest information, is part of the standard for structured cabling ISO/IEC 11801-1. At the same time it is integrated into the updated European EN 50173 standard series, which covers the industrial sector in EN 50173-3.

The matrix concept allows the division of environmental situations into three load classes which makes it possible to treat them with the use of four parameters. Class 1 corresponds to the load in the office environment and distribution rooms; class 2 is typical for light industry and class 3 corresponds to heavy industry, machine environments and outdoor conditions. The memorable name MICE stems from the individual parameters:

M = Mechanical rating
(mechanical load, shock, vibration, pressure, impact)

I = Ingress rating
(penetration of foreign particles, dust, dampness, immersion)

C = Climatic rating
(climatic load, radiation, liquids, gases, contamination)

E = Electromagnetic rating
(electrostatic, electromagnetic and similar loads)

Criteria and standards from several relevant technical areas as well as a spectrum of physical and chemical values are assigned to the primary parameters. Overall, MICE takes more than one hundred individual factors or secondary parameters into account.

MICE – No universal tool

Thus, the MICE concept represents a very broad view. Previously, only the two classes of light duty and heavy duty environments had been differentiated in the Industrial Ethernet discussion. Here too, the assumption was based on four parameters: Protection indices according to IEC or EN 60529, operational temperature, shock and vibration (IEC or EN 60068-2-x).

However, even the MICE concept is not all inclusive. It covers only typical building and industrial environments. Particular security problems (e.g. protection against manipulation and attack, safety for people and animals), fire hazard and explosion risks are not covered by the MICE classes. Electrical, nuclear and chemical risks and dangers occurring in industrial production cannot be covered across the whole spectrum. MICE is also not a universal tool for planning according to ISO/IEC 11801-3 or IEC 61918. In every case, national laws and standards as well as sector-specific safety regulations must be taken into consideration, in particular in environments where mains current is used.

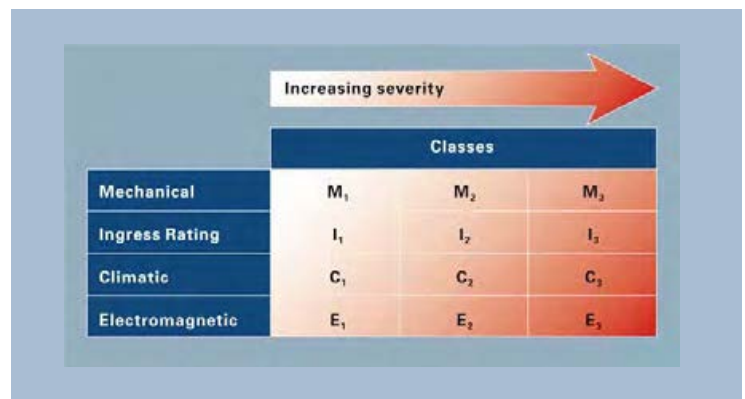

MICE classification

3. Pre-installation

The R&M warranty applies for installations in all mice classifications as long as the cable installed is suited for the MICE conditions it runs through and that the connectivity is located in a $M_2I_1C_1E_2$ or environments for screened installations and a $M_2I_1C_1E_1$ environment for unscreened installations.

3.1.3 CPR Fire protection classes (Europe only)

What is CPR (Construction Product Regulation)?

Anyone wishing to market a copper or FO cable in Europe must test, classify and label the product in accordance with the uniform European CPR rules. CE marking in accordance with the Construction Products Ordinance is mandatory for all cables and lines that are permanently connected to the building. CPR defines the fire classes of copper and FO cables by referencing to the homologated standard EN50575 and must have implemented the special CE marking and adapted to all national standards by 1 July 2017 at the latest. Deviation from these standards may no longer be allowed.

CPR requirements for manufacturers

A manufacturer producing cables and wires under the new standard is obliged to use an authorised body for testing and production inspection. The CPR-relevant properties must be stated in a Declaration of Performance (DoP). All products covered by the CPR carry a mandatory CE mark with the CPR fire class on the packaging.

Fire behaviour according CPR

The fire behavior of cables is classified as follows:

Main criteria: Flame propagation and heat emission (EN 60332-1, EN50399)

Additional criteria: Smoke development (EN 50399, EN 61034-2), corrosiveness (EN 50267-2-3) and flaming droplets (EN 50399)

EN 13501-6 defines in which combination the above test criteria can occur. The harmonized standard EN 50575 finally defines how the CPR is implemented in cabling and specifies the new fire protection classes

There are seven new Euroclasses: Aca, B1ca, B2ca, Cca, Dca, Eca and Fca.

Four of these are relevant for data cabling. B2ca, Cca, Dca, Eca.



Euro classification (ca)	Classification criterion	Additional criteria	Assessing and examining the consistency of the performance system	
A	EN ISO 1716 Gross heat of combustion		1+ Verification documents: <ul style="list-style-type: none"> • Type testing • Regular works audit • Regular sampling of ongoing production 	
B1	EN 50399 Heat release	Smoke production (s1a, s1b, s2, s3) EN 50399 / EN 61034-2		
B2		Acidity (a1, a2, a3) EN 50267-2-3		
C	Flame propagation EN 60332-1-2	Flaming droplets (d0, d1, d2) EN 50399		3 Verification documents: <ul style="list-style-type: none"> • Type testing
D	Flame propagation			
E	EN 60332-1-2 Flame propagation		4 No verification documents	
F				

CPR Classes & criteria



Recommendations for the future use of EU fire protection classes

The CPR primarily makes the fire protection properties of products comparable. However, each member state is obliged to define the minimum fire protection class required for a wide variety of applications. The requirements for the products can therefore vary greatly across Europe for each type of building. The planner must therefore check and comply with local regulations. Various organisations and international associations have now made their own recommendations, some of which go significantly beyond the minimum legal requirements. R&M makes the following recommendation based on cost/benefit considerations:

3. Pre-installation

Euro classification Flame propagation Heat production	Additional classification			Fire protection level of the installation cables (Use recommendations from R&M)*
	Smoke production/ density	Acid production/ corrosivity	Flaming droplets	
A _{ca}				NA
B1 _{ca}				NA
B2 _{ca}	s1	a1	d1	Very high (e.g. escape routes, tunnels, high-risk industries)
C _{ca}	s1	a1	d1	High (e.g. hospitals, nursing homes, schools)
D _{ca}	s2	a2	d1	Medium (e.g. public buildings, hotels, airports, industrial environments)
E _{ca}				Normal (e.g. normal office buildings, residential premises)
F _{ca}				Low (not recommended)

* The necessary fire protection classification for installation cables is prescribed by the relevant fire prevention authority.

CPR Additional classes and fire protection levels



Security system

R&M's three-layer security system provides clear component coding as well as plug-in/plug-out protection for critical data channels.

Fast installation

Fast, secure installation: snap-in DIN DRM45 rail modules, suitable for RJ45, SC-RJ or E-2000™ Compact.



Space-saving

A higher degree of automation for a rising need for information – R&M components like our FM45, which can be assembled in the field, make machine connection simple while providing maximum network availability.



Building connection

Venus boxes with protection class IP43 or IP54 protect building access nodes in the tightest of spaces.

3. Pre-installation

3.1.4 EMC concepts

In relation to obtaining a satisfactory EMC and earthing concept for the safety of personal, equipment and signals several requirements and recommendations are to be considered.

First there is the earthing network for the building(s) which forms the basis for a comprehensive EMC and safety platform. The building where information cabling is intended to be installed must be carefully inspected or designed with respect to their equipotential network. The system earthing should be designed with an aim to get low impedance in order to increase the current carrying capacity of the network. Local regulations regarding earth bonding must be complied with; however it is common knowledge that independent and dedicated earth bonding probes for individual separate networks is insufficient to obtain a good EMC protection.

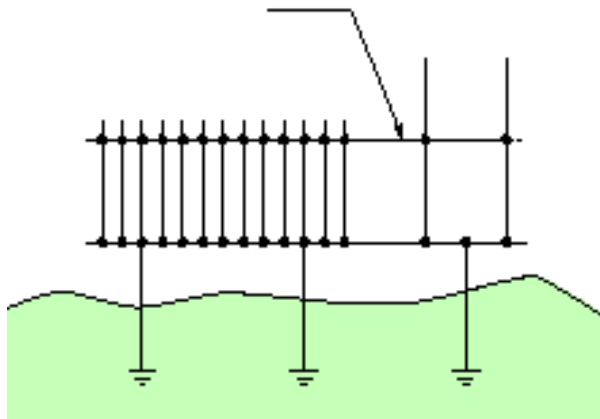

Premises earthing

In certain countries this way of bonding is even forbidden as the separate earthing method could present a serious health and safety hazard. Figure «Premises earthing» shows the preferred configurations for implementation of earthing networks. Individual earthing networks are not recommended, be it with an individual earth probe or a single earth electrode, as there is a risk the transient currents are created during a lightning strike. These fault currents and HF disturbances could subsequently

destroy equipment and cause damage to the installation. Furthermore is a two or three dimensional earthing network less maintenance prone, because when one earthing electrode breaks you have at least one or two still bonded to the earth.

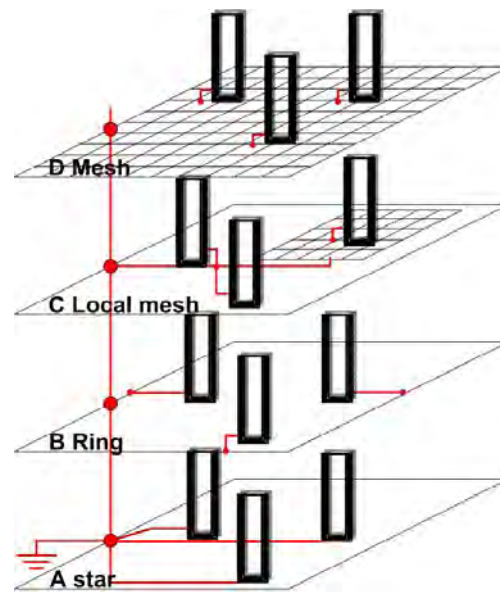

EN 50310 Minimum

If different metals are interconnected, consideration should be given to the possible deterioration of the contact points due to electro-chemical corrosion. Metals which interconnect should be selected so that their electro-chemical potentials are close or the contact point suitably protected from environmental influences (i.e. moisture). Once we are sure that our earthing network has acceptable low impedance to earth we can address the next bonding levels:

- Building level i.e. a common bonding network (CBN) or a meshed bonding network (MESH-BN)
- Installation level i.e. merging a CBN and Mesh-BN
- Equipment level i.e. MESH-BN

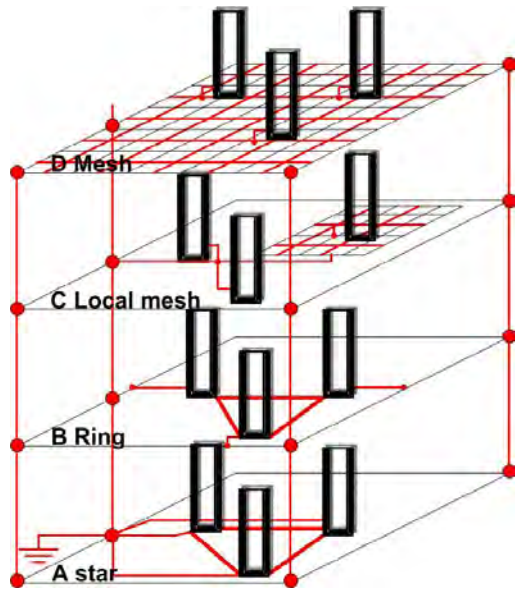

EN50310 Recommended

In order to construct a basic CBN configuration it is important to connect all metallic objects in the buildings to the earthing system using suitable interconnection components, in accordance with national and local regulations. The interconnection elements should have as large a conducting surface area as possible, so that they can conduct high-frequency currents (e.g. earthing straps, metal bus, bus links, etc.). The CBN and MESH-BN's performance can be improved by increasing the earthing network type, where the hierarchy's lowest level is A star and the highest D Mesh (see Figure «EN50310 Minimum»), or by implementing the recommended improvements shown in Figure «EN50310 Recommended».

From an installation point of view care has to be taken that the physical separation of high and low-current cables is maintained. This issue is covered in detail under [chapter 3.2.5](#) clearances between copper data and power cables

Where raised floors without support rails are used for the floor panels, the panel supports should be interconnected in an equipotential mesh pattern to achieve optimum results. It is not necessary to

connect each support with each other; in general a mesh of 1.5m is suitable. The conductor used to interconnect the columns should be at least 10mm². In case the raised floor provides an electrostatic protection, the DC resistance between the raised floor and the earthing grid needs to be between 1MΩ and 10MΩ. The previous mentioned conditions shall be recorded and re-measured when the raised floor is maintained, which is approximately every 5 years, or repaired.

All cabinets must have an earthing bar or a ground reference point, to which all metal housed equipment will be connected (including patch panels). For screened generic cabling systems the screen in the floor distributor should be connected to the earthing system, this can be done with the appropriate R&M *freenet* patch panels. If a good mesh earth is available at a particular level, the outlet can also be earthed to provide extra protection against external disturbers. For 10GBase-T and above transmission in heavy industrial environments the earthing of the outlet is recommended.

Additionally the correct power distribution should be coordinated with the electrical engineer to obtain a complete EMC valid network. If you are using an indoor secondary DC electrical distribution system it is recommended to use a DC-I installation, where the L+ and L- are routed close together. The IT system's DC return conductor will only be connected to the L+, which will be connected to the CBN and MESH-BN. The voltage drop in the DC return system shall not exceed 1V, this can be obtained by having large enough L+ and L- conductors.

3. Pre-installation

External distributor	Internal Installation	EMC	Remarks
TN-S	TN-S	Excellent	Good equipotential level
TN-C	TN-S	Good	
TN-C-S	TN-S	Good	
TN-C	TN-C	Poor	Should never be used, circulation of disturbed currents (high magnetic field radiation)
TN-C	TN-C-S	Poor	
TN-C	TN-C basement till MET & TN-S between and at floors	Good	Good equipotential level
TT	TT	Medium	Risk of equipotential problems within the building. No EMC coverage between buildings with IT, improved performance if bonding equipotential by-pass conductor is installed
TT	An isolating transformer (EN 61558-1) to realize TN-S	Good	Good inter building equipotential level
IT	IT	Medium	Commonly used isolated from earth (FR with impedance @230/440V, NO voltage limiter, no distributed neutral @ 230V line-to-line)
IT	An isolating transformer (EN 61558-1) to realize TN-S	Good	Good inter building equipotential level

EMC power distribution

For an AC electrical supply distribution system table above will provide you with the correct information to choose the optimal configuration in order to maintain the optimal EMC requirements. The European standards recommend the TN-S system, as this will cause the fewest EMC problems for IT equipment and communication. Furthermore is it recommended to install separated transformers for high power circuits, i.e. CRAC, lifts, UPS, motors. The transformer(s) for the IT systems should be in a TN-S configuration for EMC purposes and the outgoing electrical distribution circuits should all leave the main low voltage switchboard (star).

Buildings and building groups that require an excellent EMC quality, e.g. hospitals, telecom centers, military barracks, etc. should opt for a TN-S configuration to warrant their operational necessities. Especially if they use intra building cable infrastruc-

ture for their interactive services. In relation to safety of persons RCD is mandatory for TT systems and needs the continuity of the PE conductor be ensured.

TN-S and TN-C have reasonably high fault currents (transient disturbances) of ca. 1kA, which requires a good management of devices that have high leakage currents.

The latest also applies for TT systems, however here the currents are lower (few Amps). The TT and IT system however do hold the risk of overvoltages, with IT having problems the tripping of the common mode filters needed to handle the phase-to-phase voltages.

This installation guide recommendations follow the requirement outlined in EN 50174-2 and EN 50310.

Erdungskonzept für 24-Port-PC-Panel
Grounding concept for 24-Port-PC-Panel
Principe de mise à la terre pour panneau 24-Ports-PC

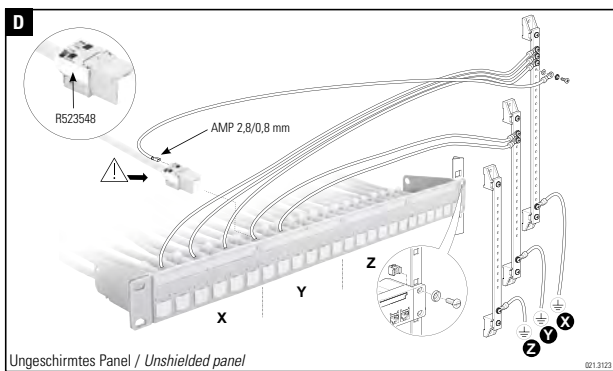
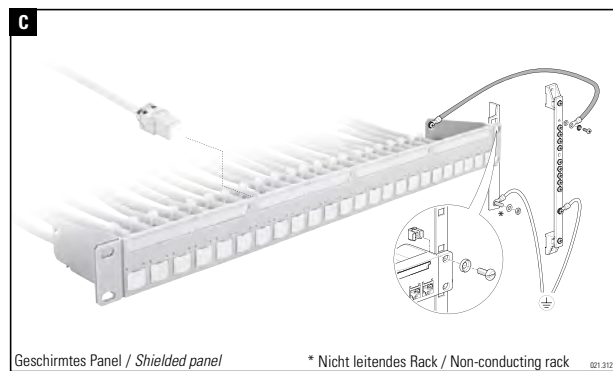
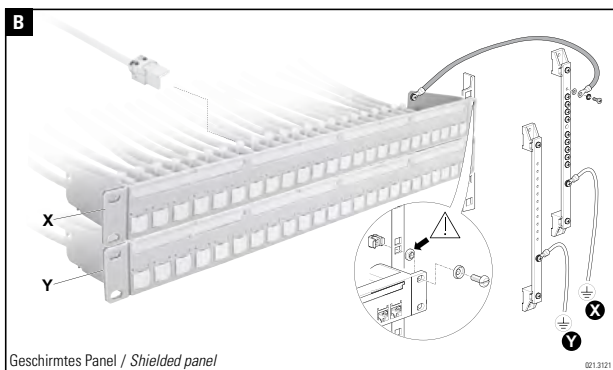
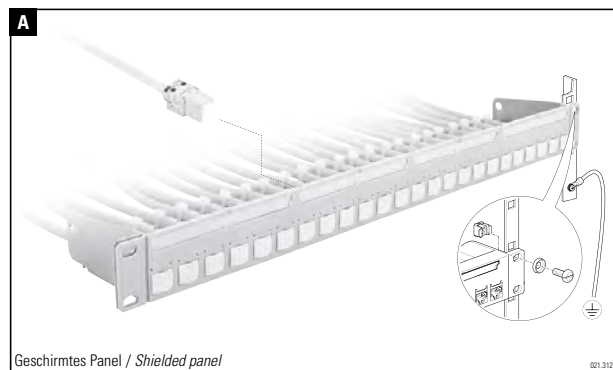

Bonding Concept R&M Panels

3. Pre-installation

3.1.5 Infrastructure program

The program comprises a number of high level definition statements that should be clearly understood and followed by the contractor.

- Room Ready RR Stage 1: All non-IT trades must be finished within the rooms. All construction, all conveyance installed, raised floor complete, decorators finish and fit-out works have been completed, a builders clean has been conducted and the room is under secure lock and any activities requires a work permit to be completed. These spaces will then be protected by temporary air curtain containing the internal environment. The rooms must be clean (and cleaned weekly for the duration, including the floor void, by the Construction Manager), decorated and protected from any dust from outside environments
- RR 2: All MEP commissioning works and structured cabling completed, final decorating snag, technology infrastructure cabling completed and core services installation proceeding. A clinical clean has been conducted of the entire environment within these spaces ahead of any main plant is connected to live power. This ensures no further air contamination will occur.
- RR 3: All power must be UPS and generator backed and on permanently (many items to be installed within these rooms require extensive programming which could be lost and require controlled shutdowns which may cause damage if not adhered to). Unscheduled and even scheduled power interruptions after hand-over of the room could result in significant delays. A minimum of 72 hours' written notice of planned power shut downs must be given. Finished doors will be required although it is recognized that they may not be initially connected to the main security system. Therefore, security guards and passes may be deemed necessary to maintain a high level of security
- Permanent Power: applicable to all HUBs and ERs. Integrated System Test IST – All building systems under change management for shutdowns, building in Operational Control.
- IT Infrastructure Permit to Operate: All base-build and fit-out plant has been commissioned and is running in a live operation without any planned or unplanned disruptions.

These milestones and definitions are a critical element of the IT program of works.

3.2 Copper

3.2.1 Copper standards

Naming conventions: ISO/EN/TIA

Differences between class and category in today's standards

ISO / EN		TIA	
System	Components	Components	System
Class D	Category 5	Category 5e	Category 5e
Class E	Category 6	Category 6	Category 6
Class E _A	Category 6 _A	Category 6A	Category 6A
Class F	Category 7	Not recognized	Not recognized
Class F _A	Category 7 _A	Not recognised	Not recognised
Class I	Category 8.1	Category 8	Category 8
Class II	Category 8.2	Not recognised	Not recognised

Standard differences

Although the performance specification of all R&M Category 5e components are to that of the ISO/IEC specified performance of Category 5, R&M generally use the naming convention of «Category 5e» or «Cat 5e» as it is more widely understood and accepted.

Component standard

Connector standard in PL and Channel

R&M System	Permanent Link (PL)	Channel (CH)
Cat. 5e	Class D	Class D
Cat. 6	Class E	Class E
Cat. 6 real 10 (screened)	Class E	Class E _A
Cat. 6 _A EL	Class E _A	Class E _A
Expected NEXT margin min. 2dB		
Cat. 6 _A ISO	Class E _A	Class E _A
Expected NEXT margin min. 4dB		
Cat. 8.1	Class I	Class I

R&M/IEEE/ENET Connector Link Classification

3. Pre-installation

Cable performance and construction

The cable nomenclature holds 2 key parameters. The first letter describes the sheath screening and the second letter the type of screening of the individual pairs.

R&Mfreenet solution	Cat. 5e Cat. 6	Cat. 6	Cat. 6 _A
U/UTP			
U/UTP WARP		<ol style="list-style-type: none"> 1. Copper core 2. Insulation 3. Spacer 4. non-continuous foil 5. Outer sheath 	
F/UTP		<ol style="list-style-type: none"> 1. Copper core 2. Insulation 3. Spacer 4. Drain wire 5. Foil 6. Outer sheath 	
U/FTP		<ol style="list-style-type: none"> 1. Copper core 2. Insulation 3. Drain wire 4. Foil 5. Outer sheath 	
F/FTP		<ol style="list-style-type: none"> 1. Copper core 2. Insulation 3. Drain wire 4. Foil 5. Foil 5. Outer sheath 	
SF/UTP S/FTP		<ol style="list-style-type: none"> 1. Copper core 2. Insulation 3. Foil 4. Braided shield 5. Outer sheath 	

TP cable structure

A complete Repertoire of RJ45 Modules

RJ45 Connectivity from R&M

The RJ45 connectivity is the core component of the twisted pair structured cabling system and is mainly responsible for its reliability. Thanks to its advanced, installation-friendly connection and distribution technology, R&M *freenet* connectivity is the optimum platform for all transmission classes and the applications of both today and tomorrow. Depending on the category of the connectors, transmission rates of up to 40 GBit/s are supported. All R&M RJ45 modules are manufactured on R&M owned fully automatic assembly lines. They are 100 % functionality tested and of topmost quality. The complete range of shielded and unshielded cabling solutions is available as part of R&M *freenet* – it provides optimal cabling components for reliable, high-performance networks.

Of course, all R&M *freenet* RJ45 modules are optimized for 4PPoE transmission and *PowerSafe*.

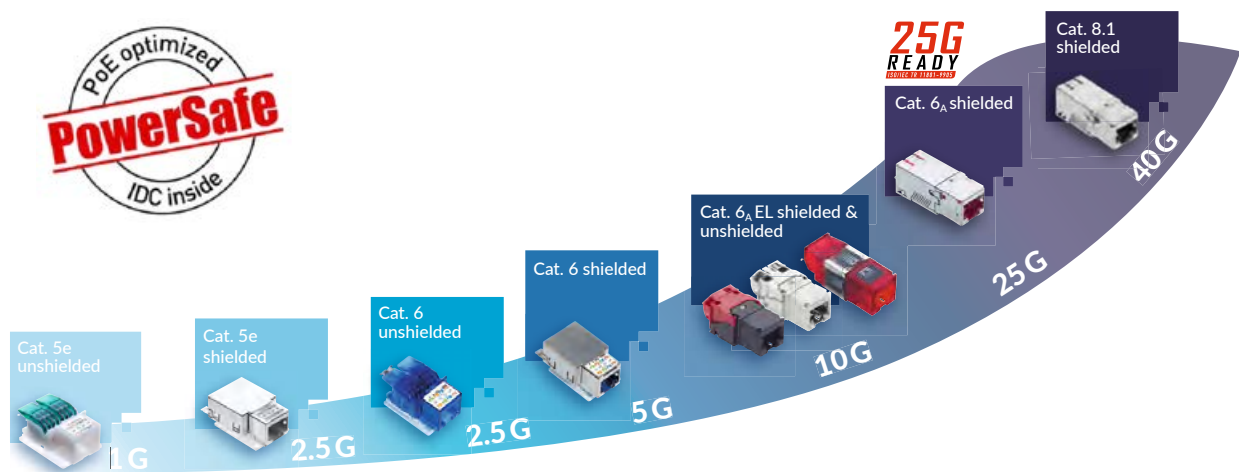

Standards, Links and Transmission Distances						
	1G	2.5G	5G	10G	25G	40G
Cat. 5e/u	90m	*				
Cat. 5e/s	90m	90m				
Cat. 6/u	90m	90m	*			
Cat. 6/s	90m	90m	90m			
Cat. 6 _A EL/u	90m	90m	90m	90m		
Cat. 6 _A EL/s	90m	90m	90m	90m		
Cat. 6 _A /u	90m	90m	90m	90m		
Cat. 6 _A /s	90m	90m	90m	90m	24m**	
Cat. 8.1	96m	96m	96m	96m	50 m***	24m

* 90m may be possible, depending on the characteristics and installation conditions of the installation cables
 ** compliant to TR11801-9905
 *** compliant to TR11801-9909

3. Pre-installation

3.2.2 Cable properties

General requirements

The bending radius is specified in the R&M data sheets in mm or as a multiple of the outer diameter of the cable (see the following excerpt from the data sheet of a data cable). A distinction is made between a minimum permissible radius during installation and a minimum permissible radius after it is laid (without mechanical load).

Properties copper cable examples			
Radii		Temperature range [°C]	
Minimum bending radius during installation	8 x D	Operation	-20 to +75
Minimum bending radius, installed	4 x D	Installation	0 to +50
Copper cable tensile strength [N]		Materials	
Maximum tensile strength during installation		PVC	IEC 60332-1
Unshielded	100	LSZH	IEC 61034, IEC 60754-1, IEC 60332-1-2
Shielded	100 - 160	LSFRZH	IEC 61034-1, IEC 60754-2, IEC60332-3-2
Maximum tensile strength, installed	No tension		
Example data sheet – copper cable		Fire load [MJ/km]	CPR
		PVC	276
		LSZH	639
		LSFRZH	550
			Cca

3.2.3 Channel restrictions for balanced cabling links

Length calculation for generic cabling systems

The following table can be used to calculate the maximum length for fixed cable installations. The length of cable calculated by the planner or installer for fixed cable installations must not be exceeded, even for possible expansions. Note that if any maintenance work is required, different lengths of patch cables or connection cables must not be used, otherwise an error-free operation of the previously calculated transmission links cannot be guaranteed. When an optional consolidation point or a cross-connect panel or both are present, the following cabling models must be differentiated. It should be noted that a NVP deviation of ~5% can occur.

Segment	Minimum (m)	Maximum (m)
FD-CP	15	85
CP-TO	5	-
FD-TO (no CP)	15	90
Work area cord ^a	2	5
Patch cord	2	-
Equipment cord ^b	2	5
All cords	-	10

^a If there is no CP, the minimum length of the work area cord is 1 m

ISO/IEC 11801 reference cabling lengths

^b If there is no cross-connect, the minimum length of the equipment cord is 1 m

LAN cabling horizontal link length equation

Model	Implementation Equation		
	Class D Channel	Class E/E _A Channel	Class F/F _A Channel
2 Connector	$H = 109 - F*X$	$H = 107 - 3a - F*X$	$H = 107 - 2a - F*X$
3 Connector	$H = 107 - F*X$	$H = 106 - 3a - F*X$	$H = 106 - 3a - F*X$
3 Connector CP	$H = 107 - F*X - C*Y$	$H = 106 - 3a - F*X - C*Y$	$H = 106 - 3a - F*X - C*Y$
4 Connector	$H = 105 - F*X - C*Y$	$H = 105 - 3a - F*X - C*Y$	$H = 105 - 3a - F*X - C*Y$

* This length reduction is to be used to provide a margin for attenuation differences at high frequencies.

Horizontal cabling link equation (See following pages for diagrams and key below)

- C** Length of the CP cable (CP = consolidation point) (m)
- F** Combined length for the patch/connection cables, equipment/workplace side (m)
- H** Maximum length for the fixed horizontal cabling (m)
- X** The cable attenuation factor for the difference between smaller copper core diameter of flexible cable and that of installation cables (UTP/STP = 1.5) and for thinLine cables (UTP/STP = 2.0)
- Y** The cable attenuation factor for difference between smaller copper core diameter of flexible cable and that of installation cables (CP – cable UTP/STP =1.5)
- L** Length of the LDP cable (LDP = local distribution point) (m)
- Z** Maximum length of the fixed zone distribution cable (m) (FD – Floor Distributor)
(TO – Telecommunications Outlet)

3. Pre-installation

LAN cabling horizontal link length models

Models

Interconnect - TO model

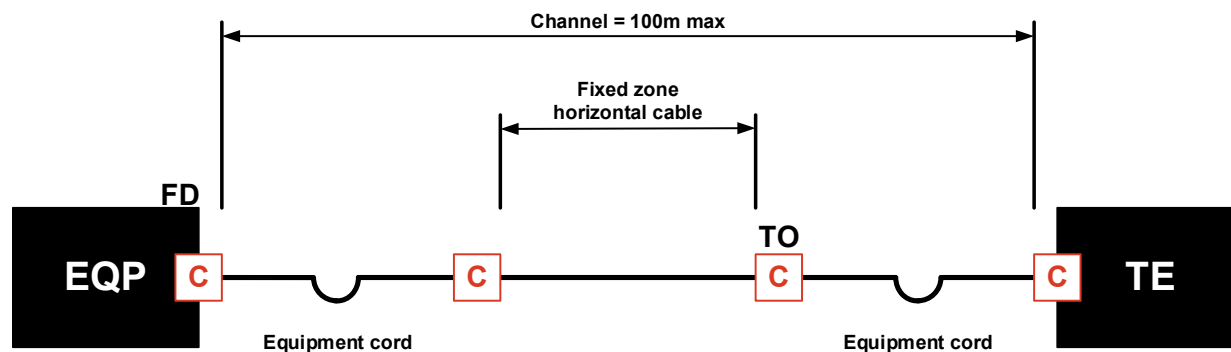

Interconnect-TO model

Implementation Equation		
Class D Channel	Class E/E _A Channel	Class F/F _A Channel
$H = 109 - F * X$	$H = 107 - 3^a - F * X$	$H = 107 - 2^a - F * X$

Interconnect-TO equation (see table «Horizontal cabling link equation» on page 41 for key)

Cross connect - TO model

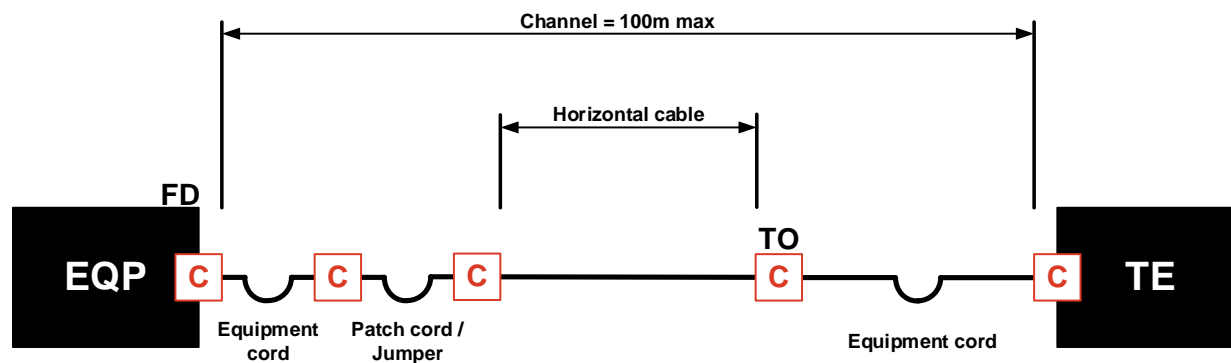

Interconnect-TO model

Implementation Equation		
Class D Channel	Class E/E _A Channel	Class F/F _A Channel
$H = 107 - F * X$	$H = 106 - 3^a - F * X$	$H = 106 - 3^a - F * X$

Cross connect-TO equation (see table «Horizontal cabling link equation» on page 41 for key)

Notes

When ambient temperature during operation is above 20°C, H must be reduced by 0.2% per °C for screened installations, for unscreened installations the value is 0.4% for between 20°C - 40°C and 0.6% for between 40°C - 60°C.

Interconnect - CP-TO model

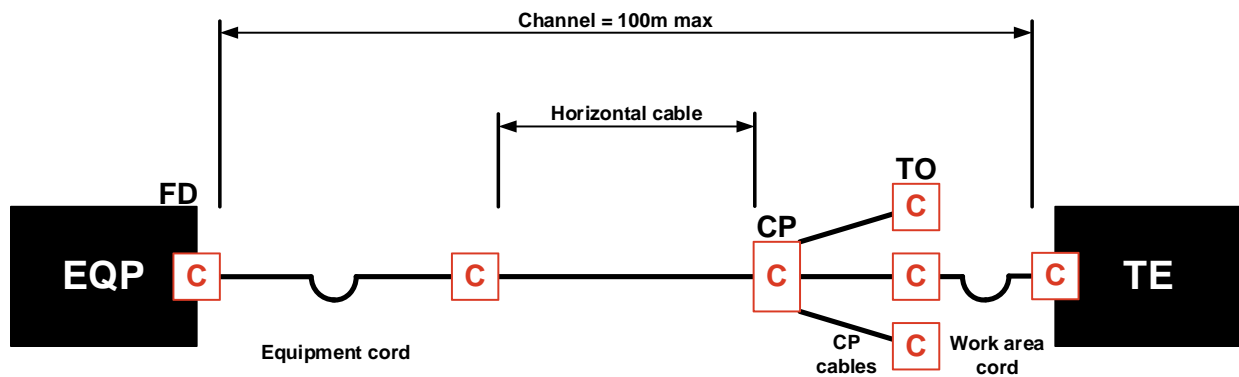

Interconnect-CP-TO model

Implementation Equation

Class D Channel	Class E/E _A Channel	Class F/F _A Channel
$H = 107 - F * X - C * Y$	$H = 106 - 3^a - F * X - C * Y$	$H = 106 - 3^a - F * X - C * Y$

Interconnect-CP-TO equation (see table «Horizontal cabling link equation» on page 41 for key)

3. Pre-installation

Cross connect - CP-TO model

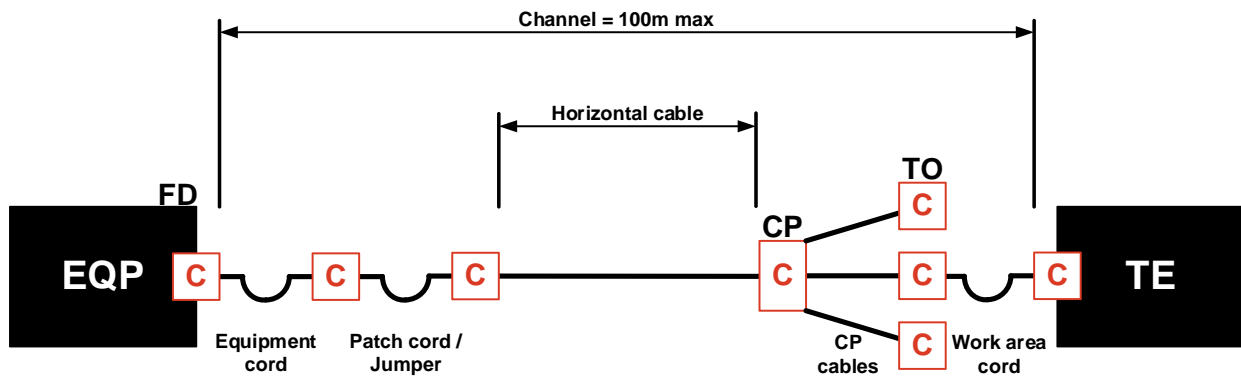

Cross connect-CP-TP model

Implementation Equation		
Class D Channel	Class E/E _A Channel	Class F/F _A Channel
$H = 105 - F * X - C * Y$	$H = 105 - 3^a - F * X - C * Y$	$H = 105 - 3^a - F * X - C * Y$

Cross connectCP-TO equation (see table «Horizontal cabling link equation» on page 41 for key)

Restrictions in accordance with reference model ISO11801

- The physical length of the permanently installed (if no CP cable is present) installation cable, permanent link, may not exceed the maximum length of 90m.
- The physical length of the channel may not exceed the maximum length of 100m.
- The consolidation point (CP) must be at least 15m away from the floor distributor.
- The CP cable connected to the TO must be at least 5m long.
- If a MUTO (multi-user telecommunication outlet) is used, the workplace connection cables must not be longer than 20m.
- Patch and connection cables may not be longer than 5m

Data center cabling zone distribution length model

Models

Interconnect - EO model

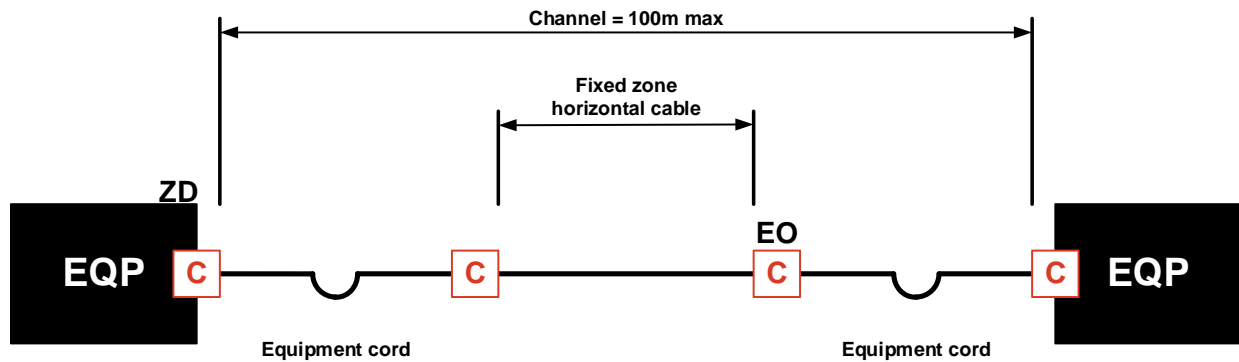

Interconnect-EO model

Implementation Equation		
Class D Channel	Class E/E _A Channel	Class F/F _A Channel
$H = 109 - F \cdot X$	$H = 107 - 3^a - F \cdot X$	$H = 107 - 2^a - F \cdot X$

Interconnect-EO equation (see table «Horizontal cabling link equation» on page 41 for key)

Cross connect - EO model

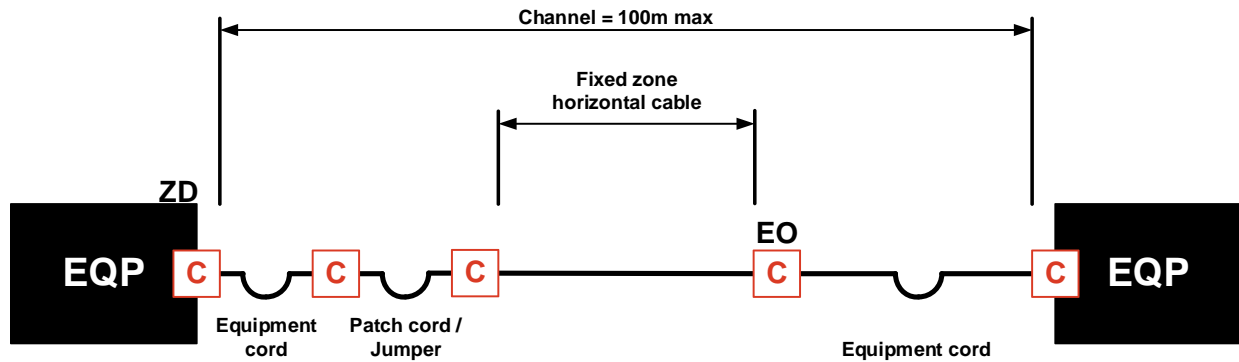

Cross connect-EO model

Implementation Equation		
Class D Channel	Class E/E _A Channel	Class F/F _A Channel
$H = 107 - F \cdot X$	$H = 106 - 3^a - F \cdot X$	$H = 106 - 2^a - F \cdot X$

Cross connect-EO equation (see table «Horizontal cabling link equation» on page 41 for key)

3. Pre-installation

Interconnect - LDP - EO model

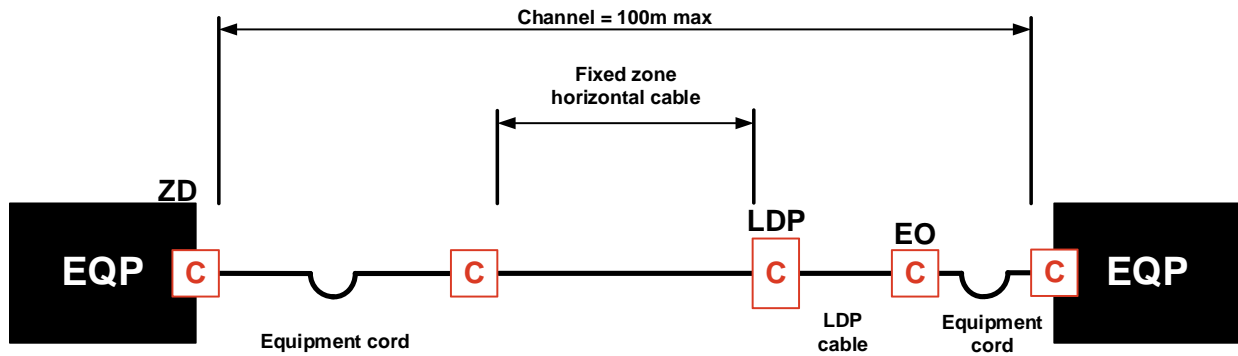

Interconnect-LDP-EO model

Implementation Equation		
Class D Channel	Class E/E _A Channel	Class F/F _A Channel
$H = 107 - F * X - C * Y$	$H = 106 - 3^a - F * X - C * Y$	$H = 106 - 3^a - F * X - C * Y$

Interconnect-LDP-EO equation (see table «Horizontal cabling link equation» on page 41 for key)

Cross connect - LDP - EO model

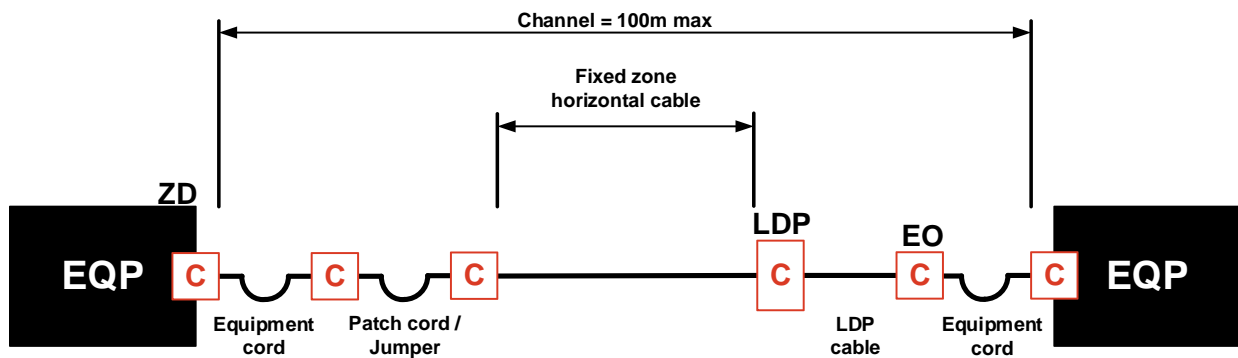

Cross connect-LDP-EO model

Implementation Equation		
Class D Channel	Class E/E _A Channel	Class F/F _A Channel
$H = 105 - F * X - C * Y$	$H = 105 - 3^a - F * X - C * Y$	$H = 105 - 3^a - F * X - C * Y$

Cross connect-LDP-EO equation (see table «Horizontal cabling link equation» on page 41 for key)

Restrictions in accordance with reference model ISO11801

- The physical length of the channel shall not exceed 100m.
- The physical length of the fixed zone distribution cable shall not exceed 90m and may be less depending on the length of LDP cables and cords used and the number of connections.

Data center cabling main distribution channel length model

Models

Main Distributor channel model

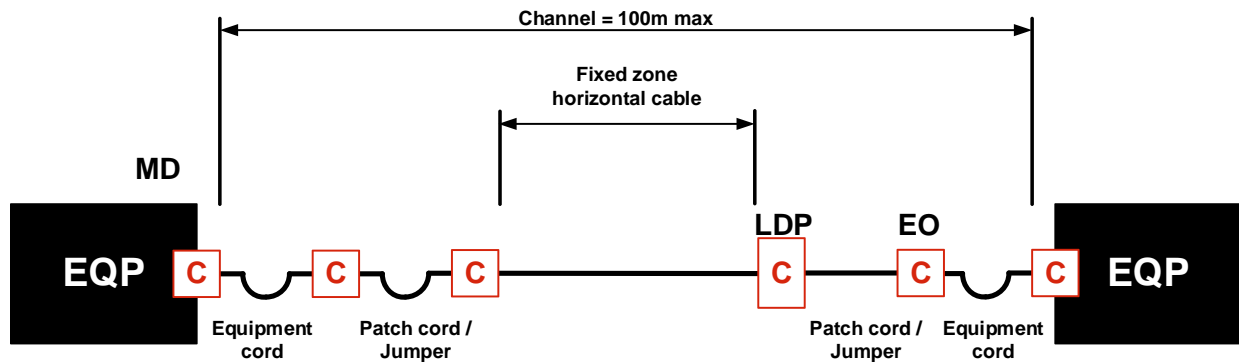

Main Distributor channel model

Implementation Equation			
Class D Channel	Class E/E _A Channel	Class F/F _A Channel	Class I/II Channel
$H = 105 - F * X - C * Y$	$H = 105 - 3^a - F * X - C * Y$	$H = 105 - 3^a - F * X - C * Y$	$H = 35 - 3^a - F * X - C * Y$

Main distributor channel equation (see table «Horizontal cabling link equation» on page 41 for key)

Restrictions in accordance with reference model ISO11801-1

- The physical length of the channel shall not exceed 100m
- The physical length of the fixed main distribution cable shall not exceed 90m and may be less depending on the length of cords used and the number of connections.

3. Pre-installation

Sample calculations for a permanently installed cabling link

1) Class D with Screened Cat. 5e installation (STP) at normal temperature

$$H = 109 - FX \Rightarrow 109 \text{ m} - (5 \text{ m} + 5 \text{ m}) \times 1.5 = 94 \text{ m}$$

The maximum allowed fixed cable link would theoretically be 94 m, but must be reduced to 90m to comply with the standards.

2) Class E_A with Unscreened Cat. 6_A installation (UTP) at 35°C ambient temperature

$$H = 106 - 3 \text{ a} - FX - CY \Rightarrow 106 \text{ m} - 3 \text{ m} - (5 \text{ m} + 5 \text{ m}) \times 1.5 - (15 \text{ m} \times 1.5) = 65.5 \text{ m}$$

$$35^\circ\text{C} - 20^\circ\text{C} = 15^\circ\text{C} \Rightarrow 15 \times 0.4\% = 6\% \Rightarrow 65.5 \text{ m} / (1.06) = 62 \text{ m} (61.8 \text{ m})$$

For this project a maximum length of 69 m of fixed cabling is permitted, with a maximum 15 m CP cable and a connection cable length of maximum 5 m.

3.2.4 Beyond the standard's length restrictions

This chapter covers the use of R&M cabling to go beyond the standards typical reference models, i.e. by using cables that are not covered in the standard, but fulfill the performance criteria or by going further than the standards maximum reference values and complying to the standards by design, based on individual performance criteria and the IEEE application parameters.

AWG26 maximum length

For installations that are relatively short, have weight limitations or a limited filling ratio for the pathways then the use of AWG 26 installation cable is a possibility. Today the use of AWG26 is mainly restricted to data center installations. Currently R&M have an AWG26 cable range in our portfolio. The table below lists the length restrictions in a Class versus component category matrix.

R&M System		Cat. 6		Cat. 6 shielded		Cat. 6 _A	
Topology	AWG	PL	CH	PL	CH	PL	CH
Class E	26	55 m	65 m	55 m	65 m	55 m	65 m
Class E _A	26				65 m	55 m	65 m

R&Mfreenet AWG26 maximum horizontal length

- PL: Permanent Link
- CH: Channel
- AWG: American Wire Gauge – Code for wire diameter either for solid or stranded wire.

The AWG 26 installation cable saves 25% – 30% of space and weight compared to AWG 23 installation cable. These savings must be bought with length restriction for permanent link and channel of 55 m and 65 m respectively.

IEEE extended channel lengths

The standards philosophy is to have guidelines that cater for every day installations and cover most technologies being used in a generic way. However there are installation requirements that sometimes just fall out of the scope of the standard. One of those situations is when a connected device to the network has a connection length longer than 100m.

There is the possibility to use the IEEE application parameters to check if a link will still support a certain application. The table below will provide an overview of the channel lengths supported by the R&Mfreenet cabling system. These channels will need to be measured in channel and not PL.

Effective Channel Lengths*	AWG 23	AWG 22	Loomed AWG 23
1000 Base-T	$H = 115 - F*X - C*Y$	$H = 120 - F*X - C*Y$	$H = 110 - F*X - C*Y$
10GBase-T	$H = 112 - F*X - C*Y$	$H = 115 - F*X - C*Y$	$H = 106 - F*X - C*Y$
Class E	$H = 111 - F*X - C*Y$	$H = 115 - F*X - C*Y$	$H = 105 - F*X - C*Y$
Class E _A	$H = 110 - F*X - C*Y$	$H = 115 - F*X - C*Y$	$H = 104 - F*X - C*Y$

*These are the straight cable lengths, i.e. fixed installed cabling plus patch cord, and CP cord if present.
The electrical length will be between 1.75%(pair12) and 5%(pair36) for AWG22, +/- 1% longer for AWG23 and +/- 6.88% for AWG23 Loomed.

R&Mfreenet IEEE maximum horizontal length (see table «Horizontal cabling link equation» on page 41 for key)

The R&Mfreenet does have a specially designed cable for even if these distances are too short, our R823885 R&Mfreenet S/FTP Class EA 105m LSFRZH AWG22 cable will be able to warrant the following distance

Effective Channel Lengths*	R823885
Class E _A	$H = 120 - F*X - C*Y$

R&Mfreenet IEEE maximum horizontal length for custom cable (see table «Horizontal cabling link equation» on page 41 for key)

3. Pre-installation

Short length supported by Cat. 6_A system

When creating the new edition of ISO/IEC 11801, the group of experts used some minimum and maximum lengths to calculate the minimum components performance. The R&M*freenet* System supports shorter links and channels. The following table is R&M cable type independent, i.e. it's for all R&M U/UTP, U/FTP, F/UTP & S/FTP cables. It is however connector dependent and below the minimum length restrictions of both our Cat6A connectors can be found.

R&M <i>freenet</i> Cat. 6 _A ISO Module	Fixed cabling	CP cord	Cross connect cord	Equipment / Patch cord
2 connector PL 2 m	2 m	Not available	Not available	Not available
3 connector PL 4 m	2 m	2 m	Not available	Not available
3 connector CH 6 m	2 m	2 m	Not available	2*1 m
4 connector CH 7 m	2 m	2 m	1 m	2*1 m

R&M*freenet* Cat. 6_A ISO minimum horizontal length

R&M <i>freenet</i> Cat. 6 _A EL Module	Fixed cabling	CP cord	Cross connect cord	Equipment / Patch cord
2 connector PL 5 m	5 m	Not available	Not available	Not available
3 connector PL 15 m	10 m	5 m	Not available	Not available
3 connector CH 14 m	5 m	5 m	Not available	2*2 m
4 connector CH 19 m	5 m	5 m	5 m	2*2 m

R&M*freenet* Cat. 6_A EL minimum horizontal length

Other connector models

One connector – Modular Plug Terminated Link (MPTL)

The one connector configuration can be found in direct CATV or security access connections, where there is no room or desire to install an outlet. There the fixed installed cable is terminated at one end directly on a plug, e.g. FM45, and with a module at the patch panel side.

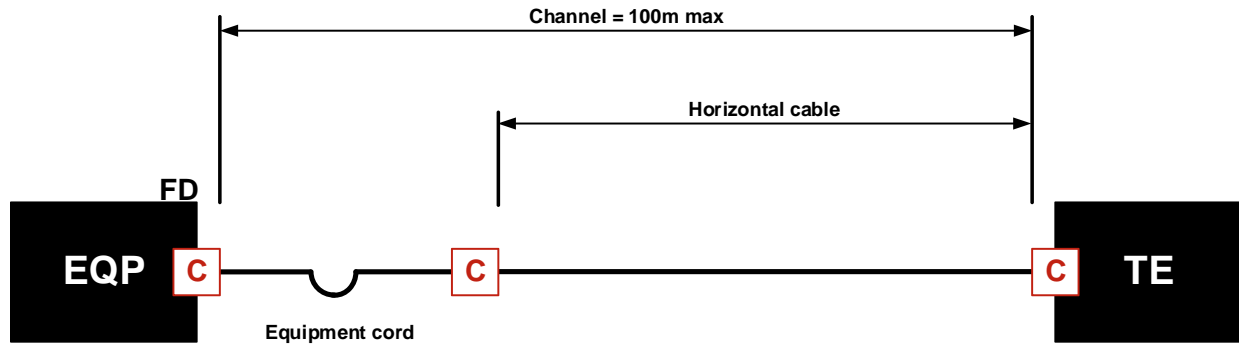

LAN one connector model

Another use could be found in a DC when the servers are directly represented in Zone Distribution rack where they are connected to the active switches.

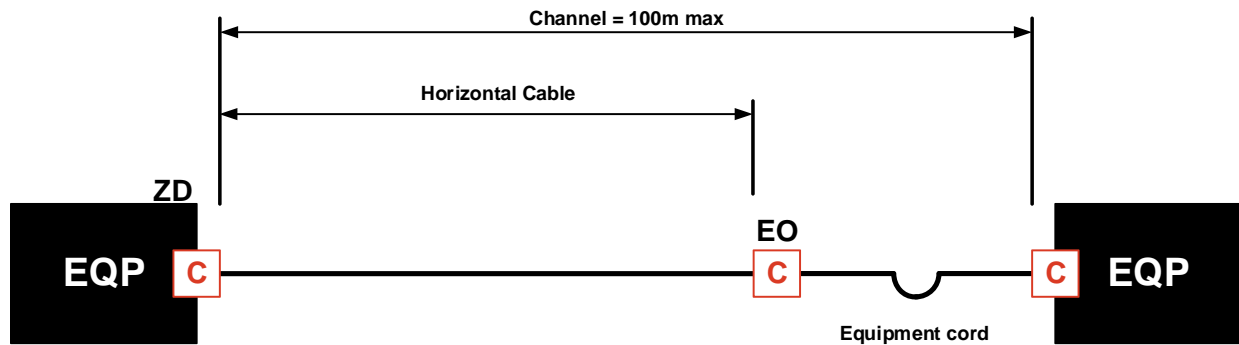

DC one connector model

Implementation Equation	
Class D Channel Cat. 5e components	Class E/E _A Channel Cat. 6/Cat. 6 _A
$H = 109 - F * X$	$H = 107 - 3^a - F * X$

One connector equation (see table «Horizontal cabling link equation» on page 41 for key)

3. Pre-installation

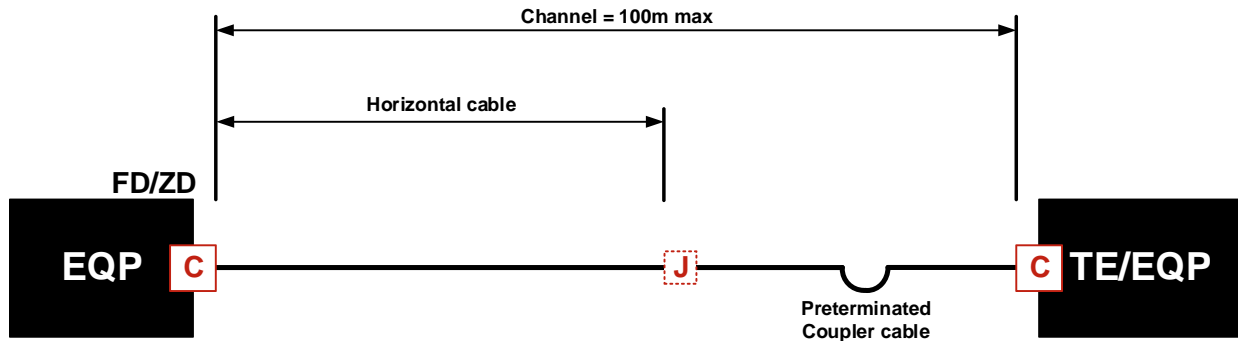

OC/DC 1-Connector Model MPTL with Cable-Coupler

Implementation Equation	
Class D Channel Cat. 5e components	Class E/E _A Channel Cat. 6/Cat. 6 _A
$H = 109 - F * X$	$H = 107 - 3^a - F * X$

One connector equation (see table «Horizontal cabling link equation» on page 41 for key)

Back to back interconnect model

This concept can be found in smaller buildings, where the backbone is also done with copper twisted pair data cable, or DCs where the zone distribution cabling and zone distribution are interlinked.

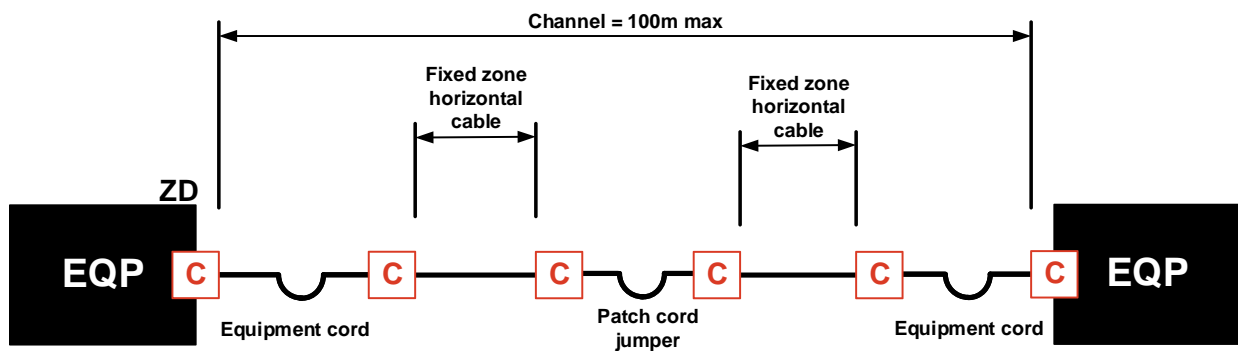

BtB interconnect model

Implementation Equation		
Class D Channel	Class E/E _A Channel	Class F/F _A Channel
$H = 109 - F * X$	$H = 107 - 3^a - F * X$	$H = 107 - 2^a - F * X$

BtB model equation (see table «Horizontal cabling link equation» on page 41 for key)

In this specific configuration the minimum distance for the horizontal cabling is 15 m.

Cross connect – interconnect – cross connect

This can occur when representing the active equipment in the zone distributor or in the main distributor. The connection between the ZD and the MD is a fixed horizontal cable.

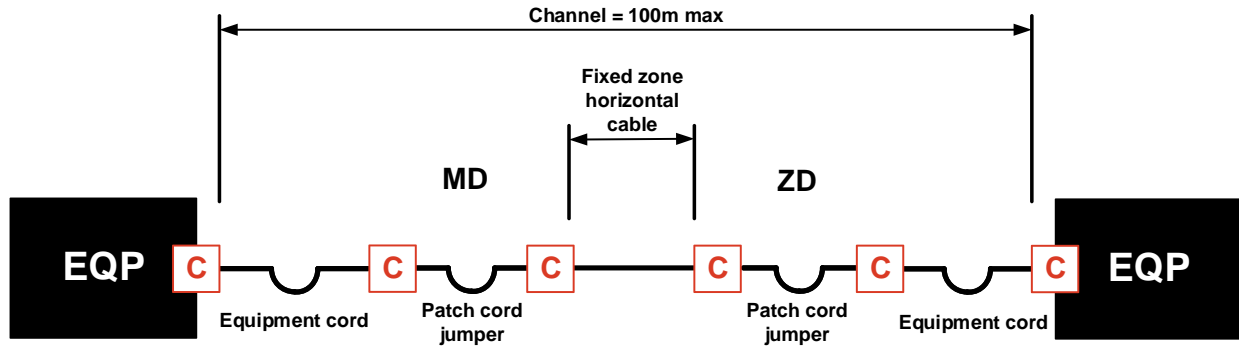

Cross-inter-cross connection model

Implementation Equation		
Class D Channel	Class E/E _A Channel	Class F/F _A Channel
$H = 109 - F \cdot X$	$H = 107 - 3^a - F \cdot X$	$H = 107 - 2^a - F \cdot X$

Cross-inter-cross model equation (see table «Horizontal cabling link equation» on page 41 for key)

This configuration can only be used in combination with the R&M *freenet* Cat. 6_A ISO module. The minimum length restriction for each part of the link is 2m.

3. Pre-installation

3.2.5 Coupler module Cat. 6_A, cable coupler Cat.6_A and connection kit RJ45

The variety of applications and the changing times require additional approaches to enable the connection of active and passive network devices in a very small space. e.g. connection of surveillance cameras, WLAN access points, consolidation points and cross connections or for certain office applications like the Desk Box.

Coupler module Cat. 6_A

The coupler module has been developed to be flexible, enabling it's use in many different applications. It allows services to be connected with standard patch cables at the back of the patch panels.

The connected service is then accessible from the front of the patch bay by means of the coupler module. The coupler module is therefore especially suitable for network components that have their interfaces on the rear side. This reduces the risk of continuity errors, distances between the patch panels and special connection cables with a plug on one side and a socket on the other. In the industrial market, coupler modules are used for point-to-point connections from the network interface (NI) to the automation island, the machine or to the Intermediate Distributor (ID).

Depending on the application, the link is measured as a PL3 if only one coupler module is used and as a channel if two coupler modules are used.



Cable Coupler

The cable coupler of the R&M *freenet* cabling system allows cables to be extended or junction boxes to be laid with a minimum of effort or cost. Other applications include cable sharing or replacing a damaged cable section. The well-known and proven IDC technology ensures fast and smooth connection of the cable without special tools. The cable coupler is suitable for transmission frequencies up to 500 MHz. The cable coupler is protected by the RCB connection box.

The cable coupler has no influence on the link performance and is normally measured as a permanent link.



Connection-Kit RJ45

Not all connections can be realized with our field mountable, FM45 connector. Problems can occur where the end device requires a direct RJ45 connection and the housing or allowable space to make the connection is limited, not allowing the use of an FM45 connector. Solution: R&M solves the challenge by means of patch cables that are already assembled on one side of a cable coupler.

The connection kit can be measured as part of an MPTL or as part of a channel.



Office

Open design of workstations with electronic devices



Fixed installations

Installation can be prepared up to the connection point, then the final assembly can be done in the shortest time.



Building automation

Flexible and fast commissioning of machines and systems.

3. Pre-installation

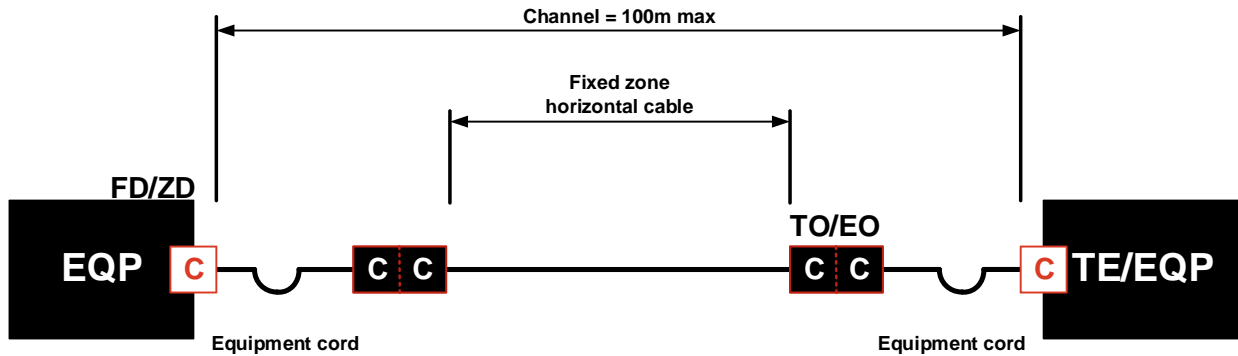

Interconnect TO/EO model with RJ45 Coupler

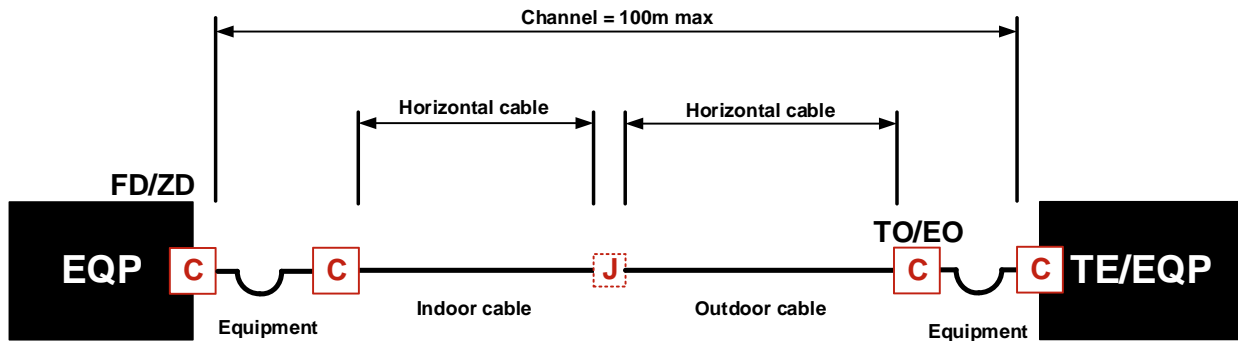

Coupled PL Indoor/Outdoor MPTL with Cable Coupler

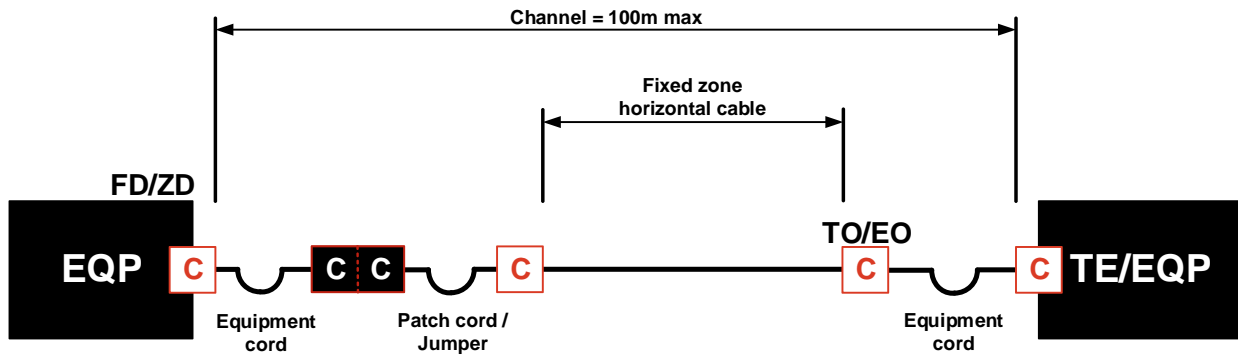

Cross connect TO/EO model with RJ45 Coupler

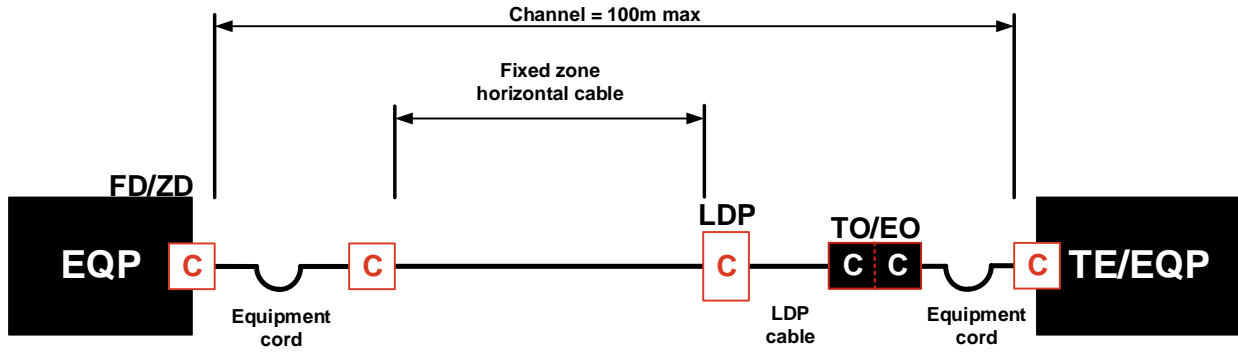

Interconnect LDP EO model with RJ45 Coupler

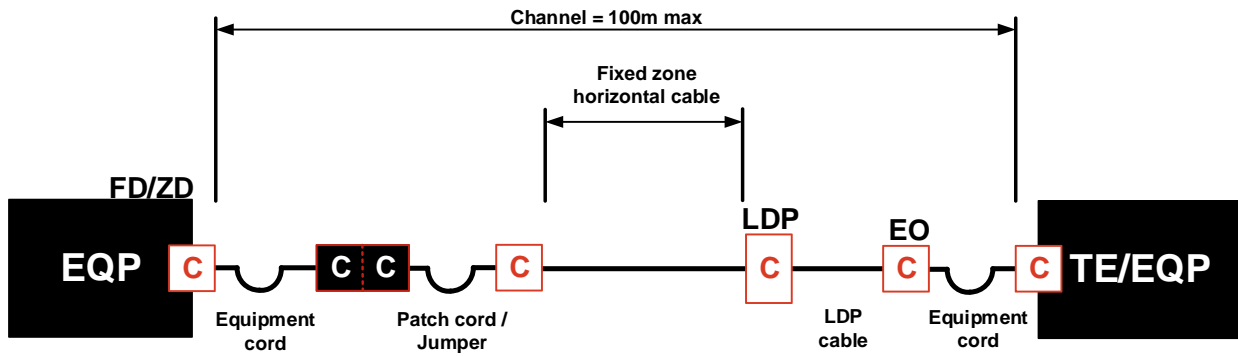

Cross connect LDP EO model with RJ45 Coupler

3.2.6 Clearances between copper data and power cables

General requirement

Maintain the minimum clearance to power cables as listed in Table «Minimum separation S according EN 50174-2» on page 60. This table lists the minimum clearance, A , between data and power cables (in accordance with EN 50174-2:2018), which must be maintained to ensure that the electromagnetic noise emission effects are kept to a minimum.

Notes

1. Local conditions may require that greater clearances than listed here be used.
2. A minimum clearance of 130 mm must be maintained between data cables and lamp mountings such as neon, incandescent and discharge lamps (e.g. mercury-vapor lamps).
3. UTP-systems intended to support 10G Base-T require significantly greater clearances than considered by EN 50174-2, it is recommended to leave a min of 300 mm between 10GBase-T data cables and power cables.
4. It is recommended that the above minimum clearances be maintained. Failure to maintain such clearance may risk EMI noise coupling that is not detected during testing.
5. In cases where it is difficult to maintain these target values (e.g. for modular partition wall systems), data cables may be routed closer to power outlet supply lines provided the following conditions are met.
 - a. Parallel cable guides up to 5 m in length are permissible, if a clearance of 25 mm can be ensured by using spacers or other appropriate means. If necessary, the clearance over a length of up to 150 mm may be less than 25 mm, as long as the cables do not touch.
 - b. Parallel cable guides up to 9 m in length are permissible, if a clearance of 50 mm can be ensured. The clearance over a length of up to 300 mm may be less than 50 mm, as long as the cables do not touch.
 - c. If several cables must be routed through a particularly cramped space, as a minimum, try to arrange the cables so that the same data cable is not routed directly beside the power cables along the entire distance.
6. Electrical panels and data cable distribution cabinets should be situated in different rooms if possible. The spacing between the distribution cabinets and the electrical panels must never be less than 1 m.

Clearances to noise emission sources

Ordinary sources of electromagnetic fields do not normally pose a problem for screened cables. As a precautionary measure, install the cables (with the exception of fiber optic cables) as far as possible from such noise emission sources – at least 1 m away. Noise coupling can also occur if data cables are routed in the vicinity of high-frequency sources such as transmission devices (antennae, transmission lines, transmitters and other radiating devices, radar installations, some industrial equipment such as high-frequency induction heaters, high-frequency welders, insulation testers, powerful electrical motors, elevators). Clearance to building structures and equipment must conform to national and local regulations.

Effect on acceptance measurements

Stray voltages can interfere with and alter field test results or sometimes make it possible to falsify field tests of data cabling systems. Ensure that these outside influences do not occur. If the test equipment warns of the presence of stray voltages, try to eliminate these voltages by switching off possible noise sources (UPS, electronic series devices, etc.). These interference voltages will also have a noticeable negative effect on the error-free operation of the network.

Cable separation and segregation

The minimum requirements for separation between information technology cables and power supply cabling can be calculated according EN 50174-2:2018 in the following way:



$$A = S * P$$

A Segregation between data and power cable

S Minimum separation see Table below

P Power cabling factor see [page 60](#)

3. Pre-installation

Minimum separation rules for STP, UTP and unbalanced cables

Information Technology Cable					
Screened		Unscreened		Coaxial/Twin axial	Segregation classification
Coupling attenuation @ 30MHz to 100MHz		TCL @ 30MHz to 100MHz		Screening attenuation @ 30MHz to 100MHz	
dB	Category	dB	Category	dB	
$\geq 80^a$	7, 7 _A	$\geq 70 - 10 \cdot \lg f$		$\geq 85^d$	d
$\geq 55^b$	5, 6, 6 _A	$\geq 60 - 10 \cdot \lg f$		≥ 55	c
≥ 40		$\geq 50 - 10 \cdot \lg f^c$	5, 6, 6 _A	≥ 40	b
< 40		$< 50 - 10 \cdot \lg f$		< 40	a

- a Cable meeting EN 50288-4-1 (EN 50173-1, Category 7) meet Segregation Classification «d».
- b Cables meeting EN 50288-2-1 (EN 50173-1, Category 5) and EN 50288-5-1 (EN 50173-1, Category 6) meeting Segregation Classification «c». These cables may deliver performance of Segregation Classification «d» provided that the relevant coupling attenuation requirements are also met.
- c Cables meeting EN 50288-3-1 (EN 50174-1, Category 5) and EN 50288-6-1 (EN 50173-1, Category 6) meet Segregation Classification «b». These cables may deliver performance of Segregation Classification «c» or «d» provided that the relevant TCL requirements are also met.
- d Cables meeting EN 50117-4-1 (EN 50173-1, Category BCT-C) meet Classification «d».

Classification of information technology cables according EN 50174-2

Containment applied to information technology or power supply cabling				
Segregation Classification	Separation without electromagnetic barrier	Open metallic containment ^a	Perforated metallic containment ^{b, c}	Solid metallic containment ^d
d	10 mm	8 mm	5 mm	0 mm
c	50 mm	38 mm	25 mm	0 mm
b	100 mm	75 mm	50 mm	0 mm
a	300 mm	225 mm	150 mm	0 mm

- a Screening performances (0MHz to 100MHz) equivalent to welded mesh steel basket of mesh size 50 mm x 100 mm (excluding ladders). This screening performance is also achieved with a steel tray (trunking without cover) of less than 1.0 mm wall thickness and more than 20% equally distributed perforated area.
- b Screening performances (0 MHz to 100MHz) equivalent to steel tray (trunking without cover) of 1.0 mm wall thickness and no more than 20% equally distributed perforated area. This screening performance is also achieved with screened power cables that do not meet the performances defined in note^d.
- c The upper surface of installed cables shall be at least 10 mm below the top of the barrier.
- d Screening performances (0MHz to 100MHz) equivalent to steel conduit of 1.5 mm wall thickness. Separation specified is in addition to that provided by any divider/barrier.

Minimum separation S according EN 50174-2

Separation requirements between metallic cabling and specific EMI sources

Sources of disturbance	Minimum separation (mm)
Fluorescent lamps	130 ^a
Neon lamps	130 ^a
Mercury vapor lamps	130 ^a
High-intensity discharge lamps	130 ^a
Arc welders	800 ^a
Frequency induction heating	1000 ^a
Hospital equipment	b
Radio transmitter	
Television transmitter	
Radar	

a The minimum distances may be reduced if appropriate cable management systems are used or manufacturer guarantees are given.

b Where there are no manufacturer guarantees, an analysis of possible interference shall be performed, e.g. frequency range, harmonics, transients, pulses, transmitted power, etc.

Separation requirements between metallic cabling and specific EMI sources according EN 50174-2

Exceptions for office premises only

Conditional relaxation of requirement

1. Where the requirements are not relevant then no separation is required where either:
 - a. the information technology cabling is application(s)-specific and the application(s) support(s) a zero segregation relaxation or
 - b. all the following conditions are met:
2. the power conductors:
 - a. form only single phase circuits;
 - b. provide a total current no greater than 32 A;
 - c. comprising a circuit are maintained in close proximity (e. g. within an overall sheath or twisted, taped or bundled together);
3. The environmental classification for the information technology cabling complies with E1 of EN 50173-1;
4. The information technology cables meet the requirements of Segregation Classifications «b», «c» or «d» in accordance with Table «Classification of information technology cables according EN 50174-2».

3. Pre-installation

3.2.7 Remote Powering – PoE, PoE+ and 4PPoE

Remote power supply via structured cabling has developed rapidly over the past 15 years. The transmittable power has increased from a modest 15W to an expected 90W at the powered device. The standard for 4PPoE (IEEE 802.3bt) was ratified at the start of 2018. R&M has already examined the effects of this increased current load on network cabling in an early white paper (see white paper «[4PPoE – Parameters for network planning](#)» at www.rdm.com). But now follows the next step in the evolution of remote power use. The conditions of use for end devices are changing. In the past, PoE-powered devices rarely used the maximum power or were only needed for a relatively short time. Typical example: the alignment and focusing of an IP camera. Once it has reached the correct position, it returns to pure transmission mode. Thus, average consumption remained relatively low. However, newer applications require maximum electrical performance in the long term. High currents flow around the clock, seven days a week (24/7 operation). Examples include networked LED lighting systems (e.g. connected lighting) in modern office buildings (digital buildings) or digitally controlled LED advertising panels and information boards (digital signage).



A typical example

The question arises as to whether the active and passive network components are designed for this continuous load. How do the high currents affect the quality of the data network in the long term? How can users counteract possible disadvantages right from the start? Manufacturers of network devices have already reacted to the changed requirements. A new generation of switches can deliver high power on all ports simultaneously and continuously. One example is the Cisco Catalyst Digital Building CDB-8x series. These switches can deliver up to 60W per port continuously. Even without a fan to provide cooling. This also changes the load on the passive network components. The following applies to cabling, distribution and connection technology: What could still be coped with under occasional peak loads quickly becomes a handicap when subjected to continuous loads



What to consider when planning for remote powering

The cable bundles heat up as a result of high currents. This is a natural effect of remote powering. Higher cable temperatures reduce the attenuation budget and thus, under certain circumstances, the maximum possible link length. But when planning with foresight, experts master this aspect with ease. The R&M PoE calculator provides assistance. The tool for planning is available at [«4PPoE – Parameters for network planning»](#).

Heat generation of remote powering

The physical sequence of a PoE application is traceable: The higher the current in a copper core and the smaller its cross-section, the warmer it becomes. typical cable construction ensures that a conductor is never alone.

The total heating of a cable depends on other factors:

- Cable design
- Number of cables in the cable bundle
- type of installation - open or in installation duct
- air convection or forced ventilation

These effects must be considered in a differentiated way. Technical Specifications such as ISO/IEC TS 29125 use calculation models that divide the temperature rise into two stages:

- temperature rise within the cable bundle
- temperature rise of the cable bundle in relation to the environment

These models can be used to calculate the expected heating for the hottest cable in a bundle. Standardization is still in flux, however, it is not the model itself that is under discussion, but the weighting of effects by the choice of coefficients. These coefficients are changed until the simulation values correspond to the actual measurements made. Higher temperatures also increase the copper resistance and thus the attenuation of the signal transmission, which reduces the effective length of the link. The heating of the cable by the current transmission can increase the attenuation of a cable to such an extent that data transmission becomes impossible.

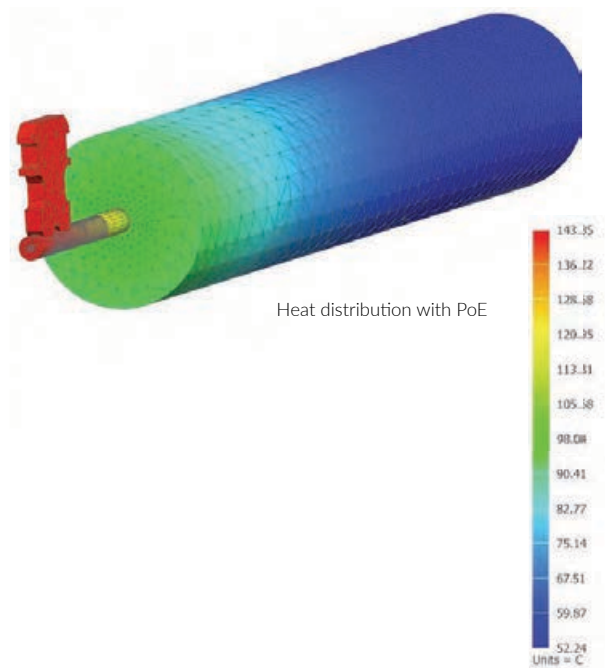

050.6451

3. Pre-installation

Connection technology IPC vs IDC

The connection technology for remote powering installations is important for the connections between the individual cores and contacts. Sustainable operational and building safety for PoE applications and highly available networks can only be achieved by selecting the appropriate termination technology. The copper cable cores are often connected to RJ45 connectors through pierced contacts (Insulation Piercing Contact, IPC). This technology carries a considerable risk. With IPC, a (non-resilient) contact plate is pressed through the stranded wire. The individual strands are located on the outside of the contact. They can make a good initial contact.

Quality assurance measures by manufacturers guarantee solid workmanship. However, only the strength of the outer plastic sheath is effectively maintaining the contact pressure. The insulation presses the outer strands against the contact surface. It is expected that this wiring is permanent. However, there is no additional robust mechanism that ensures lasting stable contacting.

- In fact, contact is gradually being lost due to:
- Age and fatigue symptoms of insulation
- Mechanical loads on the plug connection
- Thermal growth and shrinkage processes of the conductors

The contact resistance increases continuously and unpredictably. With a current load due to PoE, the temperature at the contact transition rises. The higher temperature load further deteriorates the contact: the contact resistance increases exponentially. Finally, the connection fails. The whole plug can overheat and self-destruct.

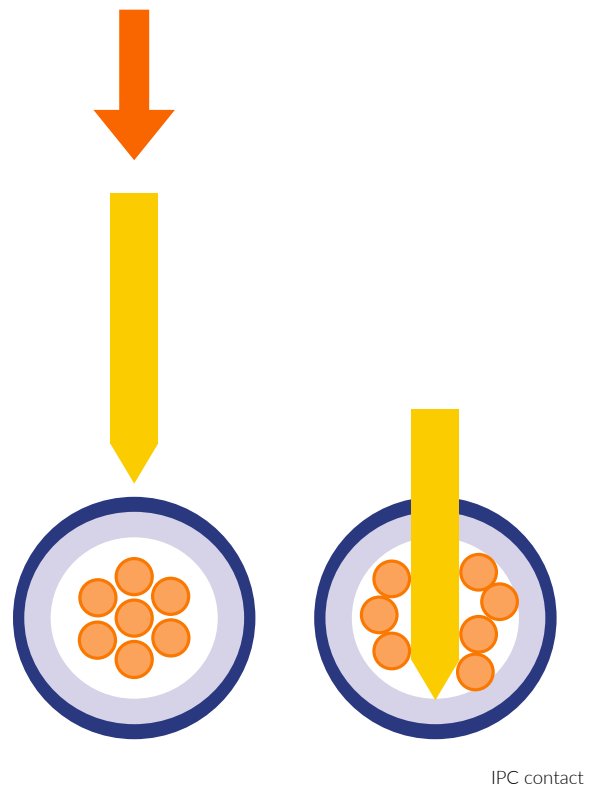

The alternative to IPC is called: Insulation Displacement Contact (IDC). With IDC, the copper core is mechanically clamped between the two legs of a spring contact as shown here. The two contact halves cut through the wire insulation and then press onto the wire in a fusing manner. They thus ensure a secure, stable contact. The circuitry also lasts if the strand should be stressed by external stress. The wire cannot move!

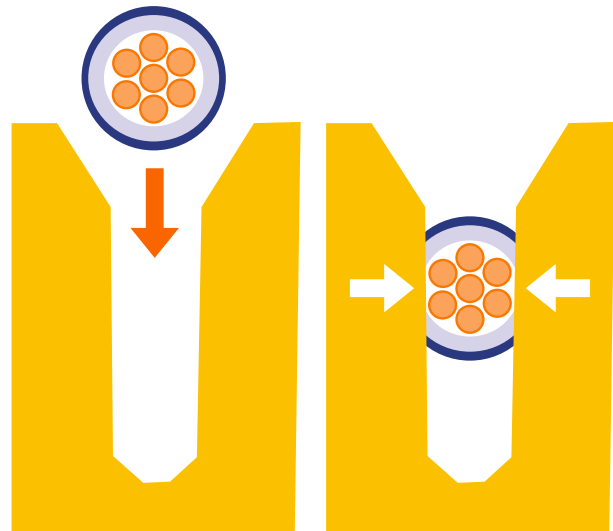

IDC contact

In addition, the IDC circuitry proves to be vibration-resistant, moisture-resistant, dust- and gas-tight and thus corrosion-protected when properly designed. The contact resistance of an IDC connection changes only slightly over time and stabilizes thereafter. This has been demonstrated by test series and decades of experience in the R&M laboratory. An IDC connection therefore ensures a reliable connection in the long term. The figure below shows the resistance behavior of a piercing and insulation displacement connection to artificial ageing in the climatic chamber.

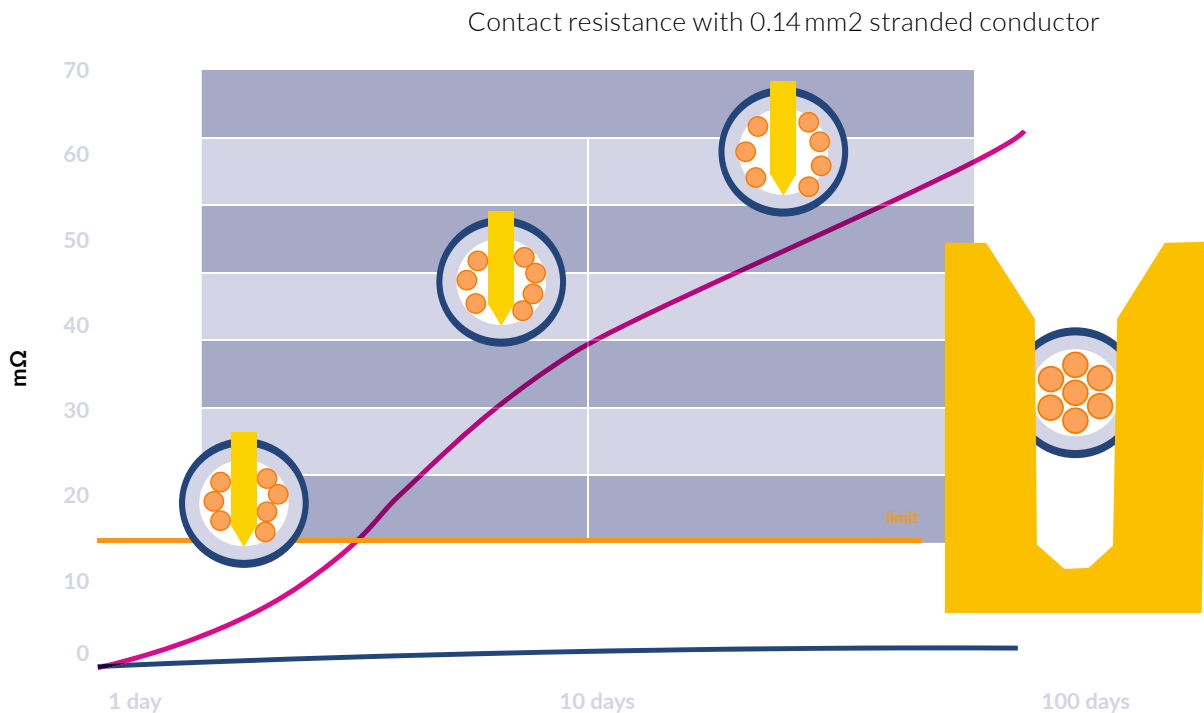

Resistance behavior

3. Pre-installation

R&M has been using insulation displacement technology for decades. Since 2000, it has also been used for the RJ45 connectors of R&M patch cords. R&M is the only manufacturer to use IDC technology in connectors for commercial patch cord production.

This makes these patch cords ideal for use in PoE systems. The wiring is characterized by a stable, reliable and low contact resistance. Added to this is R&M's internationally exemplary quality assurance system, that each individual product must pass through. R&M ensures that there are no unpleasant surprises throughout the service life of a patch cord.



RJ45 plug insert

Note: For R&M*classic* patch cords, PoE application support is excluded from the 25 year R&M*freenet* system warranty and the lifelong application warranty

Contact design

Sparking occurs when a live contact is opened or closed. For example, with Power over Ethernet (PoE), if the LAN connector is disconnected during operation. The electrical effect can be explained by the inductances on the current path: The current does not change abruptly, it «just wants to continue flowing.» In principle, sparks can also occur during insertion. With Power over Ethernet, however, this is not a problem, because the power supply device «negotiates» with the end devices to be supplied. The power supply electronics determines by resistance measurement whether the end device can accept PoE at all and if so, which power class it belongs to. Only then does the corresponding current flow. With the new 4-Pair Power over Ethernet (4PPoE) with up to 100 W power, this can be a current of up to one ampere per pair of wires. However, the electronics of the active devices cannot anticipate when someone will pull out the LAN connector. In this case, unplugging takes place under load, resulting in the break-off spark (figure below), which generates a plasma at extremely high temperatures, which can locally damage both the plug and the socket contact. Under the microscope, «burn-up» often appears as a crater in the contact material. The contact is re-established when the device is plugged in again. The contact quality and thus the security of data transmission, on the other hand, are no longer given at this point. You can use operating instructions to specify that the electrical supply in the LAN is shut down before disconnection. In practice, however, there will always be someone who will simply pull the plug.

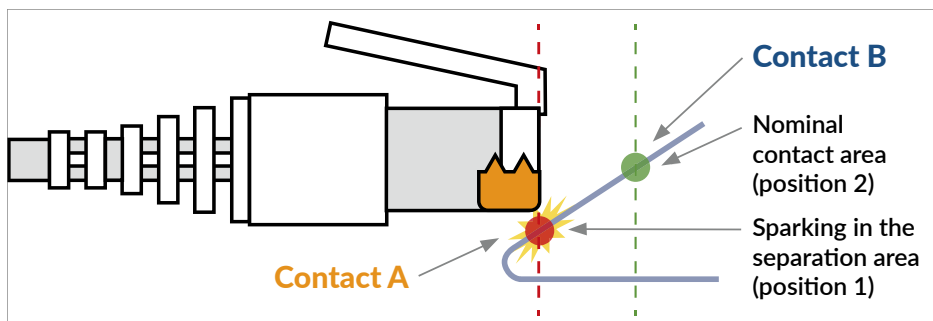

Spark when disconnection under load

R&M has designed the contacts of the RJ45 connectors and the gold-plated spring tongues of the connection modules so that the disconnection points are as far outside the nominal contact area as possible. When plugged in, they do not interfere with data transmission. The plug does not become hot due to the PoE load. R&M recommends all planners and installers of PoE-compatible networks to pay attention to such criteria, even if they are not necessarily listed in the manufacturers' data sheets. R&M has extensively investigated the effects of PoE on the connector, in particular the damage caused by sparking, and was also instrumental in standardizing this effect. This introduced the concept of the nominal contact area. During the plugging process, the contact point between contacts A and B shifts along the surface of the contacts from the first contact point (connection / disconnection area) to the end contact point (nominal contact area).

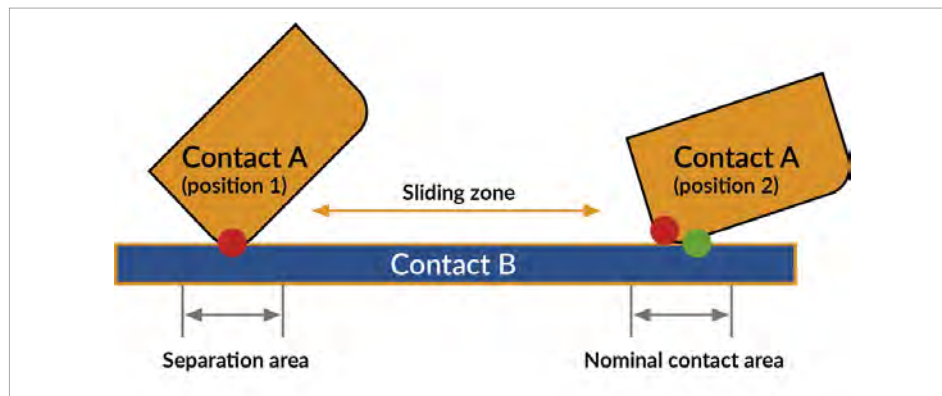

Displacement contact point during plugging process

These two areas are separated by the slide zone figure above: The design of modular connectors figure here, which is described in the IEC 60603-7 standard, should ensure that the zone in which the contact is interrupted and sparking can occur is separated from the zone in which the contact between plug and socket is established during normal operation (nominal contact area). However, the higher the power when separated, the greater the destruction of the contact in the separation area. By cleverly shaping the socket contacts, R&M has succeeded in maximizing the slide zone at the socket and plug. This makes R&M RJ45 components particularly suitable for use in 4PPoE.

There are many tester manufacturers now advising the use of a separate PoE test, but this is just a resistance balance test and does not provide a true picture of the tested systems ability to cope with power over the structured cabling system. In order to ensure successfully system support of PoE applications, there needs to be an appropriate design (using our PoE calculator), high quality cabling and the highest quality connectors in the system. R&M can ensure the successful operation of PoE applications through the use of proven quality products. These approved products specifically suited for PoE applications are given a stamp to highlight their suitability to these applications.

3. Pre-installation

Damage does not affect contact zone. Nominal contact area (green) is clearly separated

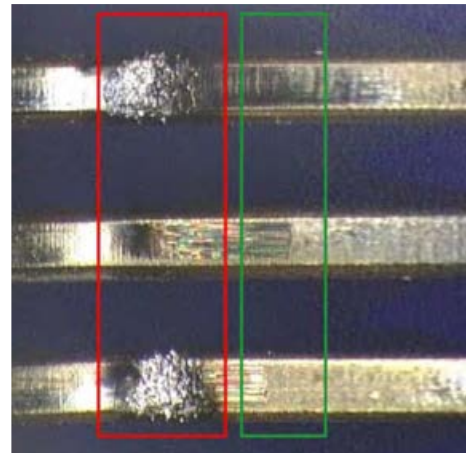

Good contact design

3.2.8 The importance of TCL test criteria for patch cords

- The symmetry or TCL (Transverse Conversion Loss) is an important parameter to ensure the performance of the cabling. It shows how well the differential transmission works in the cabling.
- TCL influences other parameters via complex coupling mechanisms, insufficient TCL component specifications can reduce channel NEXT reserves or even generate NEXT errors.
- The TCL standard specifications for shielded cables do not support 10Gbase T channel requirements. Cabling channels can have faulty NEXT, although the PL and the patch cables comply with all specifications à responsibility problem!
- Tighter patch cable specifications and sufficient NEXT reserves in the permanent link can ensure the NEXT performance of the channel
- Shielded Cat. 6 and Cat. 6_A patch cables and SP cables should be specified for frequencies above 100MHz with TCL grade 2
- Shielded Class E and Class E_A permanent links should be specified with as much NEXT reserve as possible to create reserves for standard-compliant patch cables with TCL Grade 1.

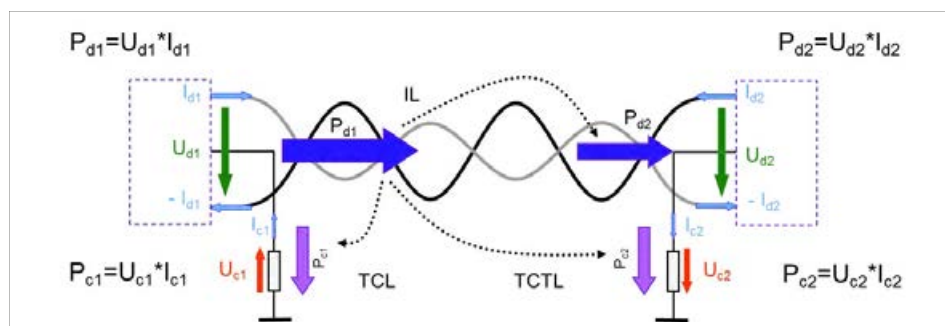

TCL influence

3.2.9 Screened vs unshielded

The introduction of 10GBase-T has had a significant influence on the choice of cabling. The increased sensitivity of the 10GBase-T transmission compared to 1000Base-T became clearly visible in unshielded cabling in the immunity against external interference. To ensure the operation of 10GBase-T, it is not enough to pay attention to the shielding alone, but the ambient conditions must be taken into account and the cabling components must be selected accordingly. Coupling attenuation can serve as a qualitative comparison parameter for the EMC behavior of cabling.

In summary, studies have shown that 10GBase-T can be used without problems in all environmental classes when using shielded cabling. The following applies: the better the screen quality, the smaller the radiation and the better the immunity of the cabling against external interference.

Unshielded cabling, on the other hand, is only suitable outside the home area and together with additional protective measures for use with 10GBase-T. Within the EU, it may only be used outside the living area in dedicated work areas (offices, computer centers, etc.).

Additional protective measures to reduce external interference:

- Careful separation of data and power supply cables or interference sources (minimum distance between data and power cables 30 cm)
- Using a metal cable routing system for data cables
- Prevent wireless communication devices from operating near the wiring
- Prevention of ESD through protective measures known from electronics production

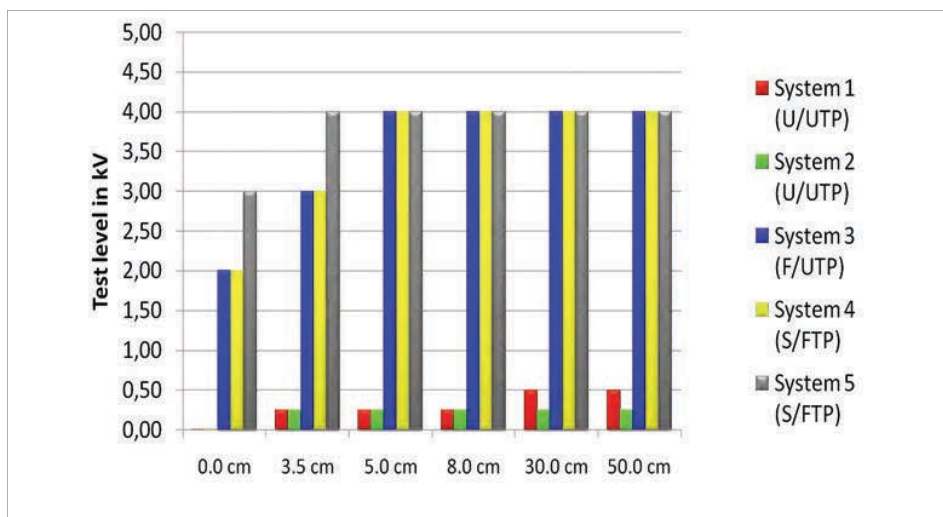

EMC radiation

3. Pre-installation

For the decision between shielded or unshielded cabling for 10GBase-T, the influences and expenses of the additional protective measures and operational restrictions must also be taken into account.

Shielded cabling should be used in industrial environments (classes E2 and E3). In difficult industrial environments (E3) an S-FTP screen construction with braided screen is necessary, and a double-sided earthing of the cabling should be used if possible.

Unshielded cabling must not be used in living areas.

In offices and data centres with unshielded cabling, the above-mentioned additional protective measures must be prescribed.

3.2.10 Testing Class E_A Installation according ISO/IEC TR11801-9905

ISO TR11801-9905 specifies the requirements to enable a Category 6_A compliant system to support the IEEE 25GBase-T application. We at R&M recognize this important step and have developed the following guidelines to satisfy the requirements using R&M components and can also provide a warranty that recognizes such next generation systems.

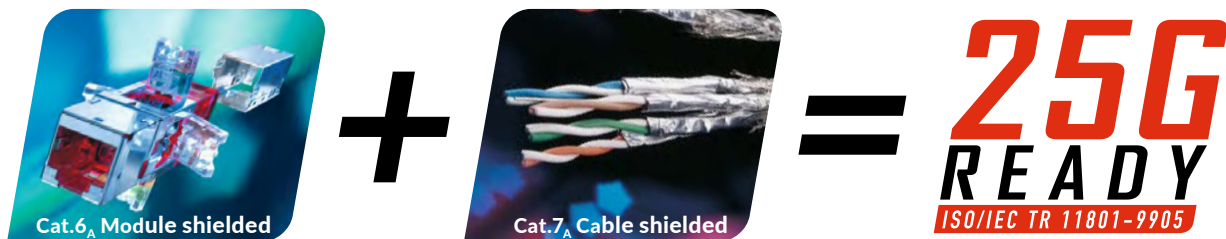

Following the standard installation protocols and adhering to the length restrictions cited in ISO TR11801-9905, a system made up of specifically recognized R&M components can be given the unique «25G Ready» warranty approval along with the regular ISO 11801 Class E_A standards warranty.

- Upgrading Class E_A installation
- Length dependent speed
- Combination: Cat.6_A /s module and Cat.7_A S/FTP cable required
- Acc. ISO/IEC TR11801-9905
- R&Mfreenet system warranty
- Future proofs Class E_A links for coming generations WAP and DAS

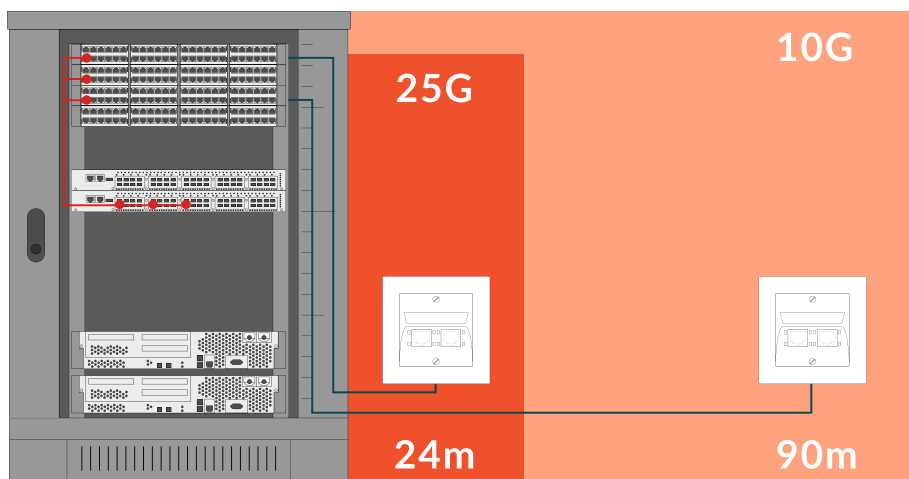

Length restrictions 25G-ready

3. Pre-installation

Verification procedure for 25G Ready

Valid for components marked with «25G READY» symbol.

Step 1:

Permanent Links measured acc. ISO/IEC 11801 Class E_A

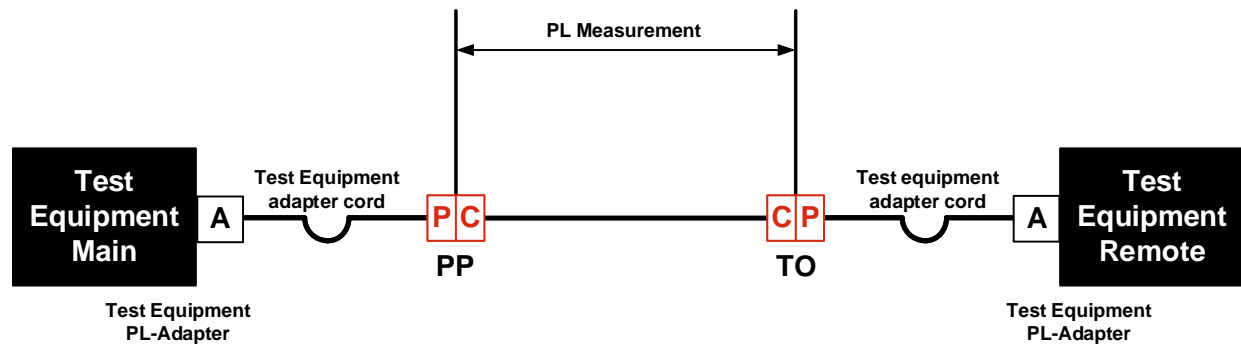

Sample test PL

Step 2 for Links 5 - 24 m:

Channel measurement acc. ISO/IEC TR11801-9905

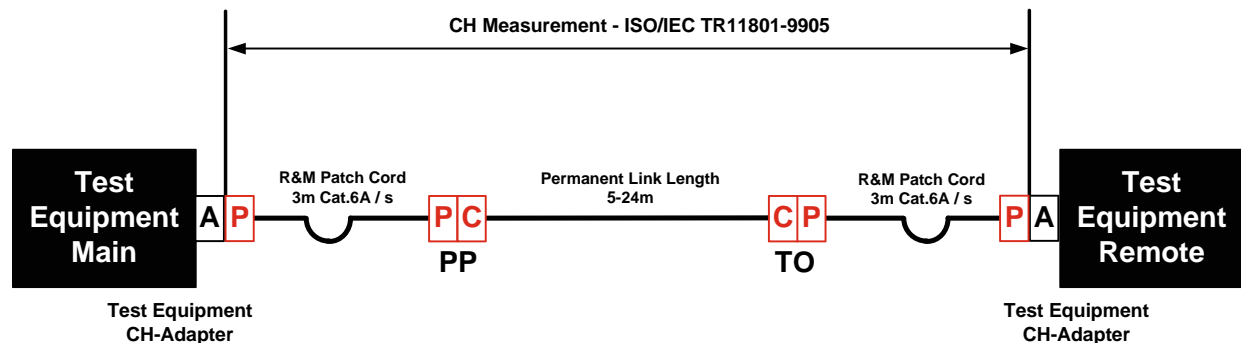

Sample test 25G

For verification of a «25G Ready» system, only products marked with «25G Ready» must be used. Firstly, the system must pass the ISO 11801 Class E_A system test, then a channel measurement according ISO/IEC TR11801-9905 can be conducted. (Please check that the test device has the option to test for this specific application).

This channel test must be made using the above specified R&M measurement patch cord.

Category 8

For the latest test procedures advised for R&M Class I / Category 8.1 systems, please refer to our information found online at www.rdm.com

3.2.9 Category 8

Due to the prevalence of RJ45 applications and the full backward compatibility with existing cabling systems misleading to mention just one Category, R&M has decided to offer Category 8.1 – in other words, to retain the successful RJ45 approach. Only the two-connector model can be implemented in the Category 8 environment. The permissible length of the Permanent Link (PL) with Category 8.x can be derived from the maximum electrical length of the transmission channel (channel, 32 m) minus the length (LPC) and type of the patch cords used.

This can be calculated as follows: $L_{PL} = 32 - L_{PC} * X_{PC}$

Where LPL = maximum length of Permanent Link and LPC = Combined length of all patch cords in the channel. The factor XPC depends on the type of patch cord: AWG22/23: 1, AWG24: 1.25, AWG26: 2

The two standardization committees ISO/IEC SC25 and TIA TR42 have specified the maximum lengths for cabling elements. Unfortunately, these vary according to the committee:

	ISO & IEC	TIA	R&M Recommendation
Permanent Link	5 m – 26 m	Max. 24 m	5 m – 24 m
Total length of patch cords	2 m – 4 m	Max. 6 m	2 m – 4 m
Electrical channel length	Max. 32 m	Max. 32 m	Max. 32 m
Mechanical channel length	Max. 30 m	Max. 30 m	Max. 28 m

Length restrictions for Class I / Cat. 8

Adhering to R&M's specifications ensures that all specifications of both standardization families are fulfilled even if different types of patch cords (AWG 26 - 22) are used in operation.

Schematically, a Category 8.1 channel can be represented as follows:

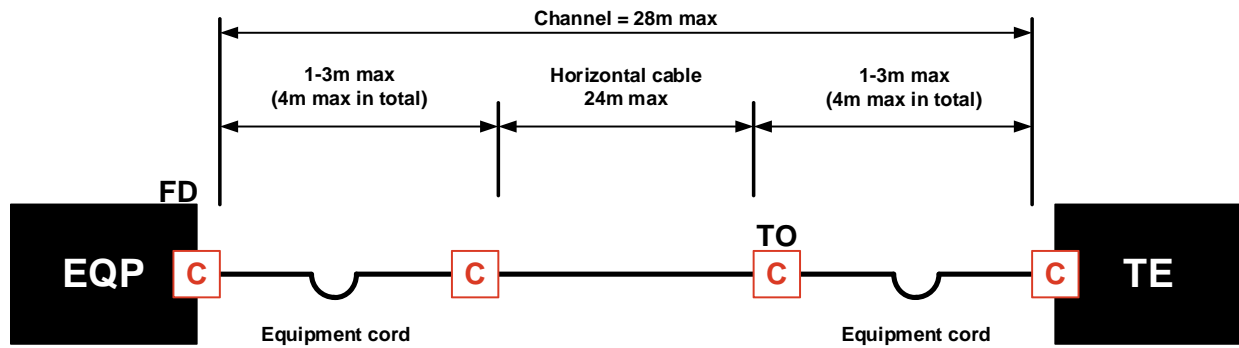

Schematic representation of Cat. 8.1 channel with length specification

An AWG22 installation cable of type 8.1 SF/UTP or F/UTP as well as of type 8.2 S/FTP or F/FTP is designated to be used for the PL. There is no purely unshielded variant possible due to the frequency of 2000 MHz. Shielded patch cords of type 8.x can be connected to this PL. If a patch cord is longer than 2 m, the total length of patch cords in use must be coordinated to ensure that a total of 4 m is not exceeded.

The names used when referring to Category 8 components may at times be confusing and unclear. But the division is easily and quickly clarified with an overview matrix. Basically, the TIA does not deal in transmission classes. Unlike ISO/IEC, there is no distinction between component category and link class. Furthermore, the ISO/IEC recognizes the additional categories Cat. 7 and Cat. 7_A. However, there are no data applications for the corresponding transmission classes F and F_A.

3. Pre-installation

Standard	ANSI / TIA	ISO / IEC	ISO / IEC	R&M characteristics
Component designation	Cat. 8	Cat. 8.1	Cat. 8.2	
Link designation	Cat. 8	Class I	Class II	
Installation cables	F/UTP, or x/FTP, AWG22 to AWG24, max. diameter 9 mm	F/UTP, SF/UTP or x/FTP, max. diameter 9 mm	x/FTP, max. diameter 9 mm	Exclusively S/FTP, AWG22 available, max. 2 GHz
Modules	RJ45	RJ45	GG45 or TERA	
Patch cords	Shielded AWG26 to AWG22, max. diameter 8 mm	Shielded AWG26 to AWG22	Shielded AWG26 to AWG22	Exclusively S/FTP, AWG26 available, max. 2 GHz
Connectors	RJ45	RJ45	RJ45/ARJ45 or TERA	

R&M system environment

Components requirements for standards

The requirements made of the installation cables of Category 8.1 were defined for a x/UTP construction. For technical reasons, however, such cables are not yet available. Cat. 8.2 installation cables in S/FTP construction are, however, available and technically sophisticated. Every Cat. 8.2 cable also fulfills the requirements of Cat. 8.1. An S/FTP construction which only attains Cat. 8.1, and not Cat. 8.2, would be likely to have inherent technical deficits. This is why R&M only offers Cat. 8.2 installation cables even in a Class I system.

Use in the data center

When it comes to data center cabling, it can be assumed that the adaptation mainly depends on prices and the availability of the terminal equipment. In principle, there are two general applications for data centers, top of rack (ToR) and end of row (EoR), which were the origin of the development of Category 8.

Category 8.1 also in the LAN environment

Access points for WiFi6 and Distributed antenna systems for 5G are driving the bandwidth requirement beyond 10Gbit/s in the near future. 25Gbit/s transmission hardware is already in development. A suitable cabling structure is required for this application today. It is safe to assume that Cat. 8.1 will find its way in the LAN environment when the 25GBase-T variant is launched. The transmission frequencies of 1,600MHz required for a data rate of 40GB/s limit the attainable link length to 24 meters due to the high attenuation values of the cabling at these frequencies. At 10GB/s and 400MHz, this length is over 90m. Estimates for 25GB/s and 1,000MHz would suggest an attainable link length of 50m. This achievable length is examined in more detail in the technical report from ISO/IEC TR11801-9909. With an achievable link length of 50m, around 60% of all required links can be realized in the LAN environment. This makes Cat. 8.1 a feasible solution for the LAN.



030.5985

3.3 Fiber

3.3.1 Fiber standards

The standard describes the difference between channel and link transmission. However, this has no influence on the calculation of the channel attenuation, but plays a role in determining the measurement limits and the test procedure.

In this chapter we discuss the correct calculation for the planning of fiber optic routes. The [chapter «Post-installation»](#) explains the detailed test criteria and correct calculations for determining the measurement limits.

Fiber channel standards

The corresponding applications are listed in ISO/IEC 11801-1 and in the table below. It is assumed that every single channel within an installation includes fibers of the same specification unless otherwise stated.

IEEE Applications supported MMF			
Application	Wavelength (nm)	Max. Attenuation (dB)	Max. Length (m)
10Base-FL&FB	850	6.80	1514
100Base-FX	1300	6.00	2000
1000Base-SX	850	3.56	550
1000Base-LX	1300	2.35	550
10GBase-LX4	1300	2.00	300
10GBase-LRM	1300	1.90	220
10GBase-SR	850 OM3[OM4]	2.60[2.90]	300[400]
40GBase-SR4	850 OM3[OM4]	1.90[1.50]	100[150]
100GBase-SR4	850 OM3[OM4]	1.80[1.90]	70[100]
100GBase-SR10	850 OM3[OM4]	1.90[1.50]	100[150]
1 Gbit/s FC	850 OM3	2.62	500
2 Gbit/s FC	850 OM3	3.31	300
4 Gbit/s FC	850 OM3[OM4]	2.88[2.95]	380[400]
8 Gbit/s FC	850 OM3[OM4]	2.04[2.19]	150[190]
16 Gbit/s FC	850 OM3[OM4]	1.86[1.95]	100[125]
32 Gbit/s FC	850 OM3[OM4]	1.75[1.86]	70[100]

IEEE applications supported MMF (ISO/IEC 11801-1)

3. Pre-installation



IEEE Applications supported SMF			
Application	Wavelength (nm)	Max. Attenuation (dB)	Max. Length (m)
1000Base-LX	1310	4.56	2000
10GBase-LX4	1310	6.20	2000
10GBase-ER	1310/1550	10.90	2000
10GBase-LR	1310	6.20	2000
40GBase-LR4	1310	6.70	2000
40GBase-FR	1310/1550	4.00	2000
100GBase-LR4	1310	6.30	2000
100GBase-ER4	1310/1550	18.00	2000
1 Gbit/s FC	1310	7.80	2000
2 Gbit/s FC	1310	7.80	2000
4 Gbit/s FC	1310	4.80	2000
8 Gbit/s FC	1310	6.40	2000
16 Gbit/s FC	1500	6.40	2000
32 Gbit/s FC	1310	6.40	2000

IEEE Applications supported SMF (ISO/IEC 11801-1)

Fiber connection standards

In contrast to their electromechanical counterparts, with fiber-optic connectors no differentiation is made between plug and jack. Fiber-optic connectors contain a ferrule for the accommodation and exact positioning of the fiber end and are attached to one another via a coupler with a sleeve. A complete plug-in connection consists of the combination connector/coupler/connector. The two ferrules with the fiber ends must meet each other so precisely inside the connection that the least possible amount of light energy is lost or reflected (return loss). The determining factor is the geometric orientation and workmanship of the fiber in the connector.

Core diameters of 9 μm for single-mode or 50 μm for multi-mode fibers and ferrules with 2.5 mm or 1.25 mm diameter make a visual inspection of the connector condition without special equipment impossible. Naturally, one can determine on the spot if a connector is correctly snapped in and locked. For all other characteristics – the «intrinsic values» – for example insertion loss, return loss, or mechanical stability, users must be able to rely on the manufacturer's data.

Connector	Type	Standard	Info
	ST 2.5 mm MMF, MF PC	IEC 61754-2	These connectors with bayonet-lock were the first PC connectors (1996). Thanks to this fact and the extremely robust design, they can still be found world-wide in LAN networks (primarily industrial). ST is the designation for «straight type».
	SC 2.5 mm MMF, SMF PC, APC	IEC 61754-4	This type of connector with a quadratic design and push/pull system (SC stands for Square Connector or Subscriber Connector). The compact design of the SC allows for a high packing density. It can be combined to duplex and multiplex connections. Although among the oldest connectors, it has excellent properties. To this day it is the most important WAN connector world-wide, thanks to excellent optical properties. SC is also wide-spread in a duplex version, particularly in local area networks.
	MPO MMF, SMF PC, APC	IEC 61754-7	The MPO (multi path push-on) is based upon a plastic ferrule that typically holds 12 or 24 fibers in one connector. In the meantime, connectors with up to 72 fibers are in development. The connector is distinctive due to its compact design and simple handling, but has disadvantages in optical performance and reliability.

FO connector types – part 1

3. Pre-installation

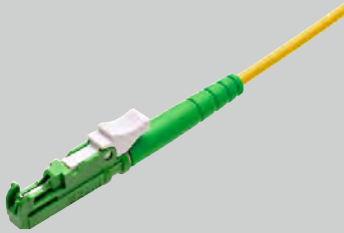
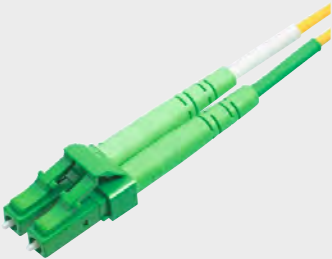

Connector	Type	Standard	Info
	E2000TM, LSH 2.5 mm MMF, SMF PC, APC	IEC 61754-15	<p>This connector is a development of Diamond SA, which focuses on LAN and CATV applications. It is produced by three licensed manufacturers in Switzerland, which also results in an unmatched standard of quality. The integrated protective shutter protects against dust and scratches, but also against laser beams. The connector has a locking latch retention mechanism that is coded both mechanically and according to color. It is the first connector to achieve Grade A performance</p>
	LC 1.25 mm MMF, SMF PC, APC	IEC 61754-20	<p>The connector belongs to a new generation of compact connectors. It was developed by the company Lucent (LC stands for Lucent Connector). Its construction is based upon a ferrule with 1.25 mm diameter. The duplex coupler matches the size of an SC coupler (SC footprint). This allows very high packing density, making its usage in data centers attractive. Is the defacto standard connector in the enterprise market due to the backing from the main equipment manufacturers. The optical and mechanical performance is below the level of an SC-RJ or E-2000™.</p>

FO connector types – part 2

Connector	Type	Standard	Info
	SC-RJ 2.5 mm MMF, SMF PC, APC	IEC 61754-24	<p>As the name already reveals, the developers at R&M oriented themselves on the RJ45 format. Two SCs form a unit in the size of an RJ45. This is equivalent to the SFF (Small Form Factor). 2.5 mm ferrule sleeve technology is used. This is more robust and reliable when compared to the 1.25 mm ferrule. The SC-RJ impresses not only with its compact design, but also with optical and mechanical performance. It is an all-rounder – usable from Grade A to M, from single mode to POF, from WAN to LAN, from laboratory to outdoors. For the latter usage, the IP67 version of the SC-RJ is recommended. R&M has released a white paper covering the SC-RJ («SC-RJ – Reliability for every Category»).</p>

FO connector types – part 3

3. Pre-installation

Connector	Type	Standard	Info
	ST 2.5mm MMF, SMF PC	IEC 61754-2	These bayonet couplers were the first PC connectors (1996). Due to this and the very robust design, they are still used worldwide in LAN networks (mainly industry). ST is the name for «Straight» type.
	LC 1.25 mm MMF, SMF PC, APC Flangeless, Screwable	IEC 61754-20	The coupler belongs to a new generation of compact connectors. It was developed by the company Lucent (LC stands for Lucent Connector). Its construction is based upon a ferrule with 1.25 mm diameter. The duplex coupler matches the size of a single SC coupler (SC footprint). This allows very high packing density, making its usage in data centers attractive. Is now the defacto standard connector in the enterprise market due to the backing from the main equipment manufacturers. The optical and mechanical performance is below the level of an SC-RJ or E-2000™.
	E2000™ Compact E2000™ 2.5 mm MMF, SMF PC, APC Flangeless, Screwable	IEC 61754-15	This coupler is a development of Diamond SA, which focuses on LAN and CATV applications. It is produced by three licensed manufacturers in Switzerland, which also results in an unmatched standard of quality. The integrated protective shutter protects against dust and scratches, but also against laser beams. The coupler has a locking latch retention mechanism that is coded both mechanically and according to color.

Fiber adapter types – part 1

Connector	Type	Standard	Info
	<p>SC-RJ 2.5 mm MMF, SMF PC, APC Flangeless, Screwable</p>	<p>IEC 61754-24</p>	<p>As the name already reveals, the developers at R&M oriented themselves on the RJ45 format. Two SCs form a unit in the size of an RJ45. This is equivalent to the SFF (Small Form Factor). 2.5 mm ferrule sleeve technology is used. This is more robust and reliable when compared to the 1.25 mm ferrule. The SC-RJ impresses not only with its compact design, but also with optical and mechanical performance. It is an all-rounder – usable from Grade A to M, from single mode to POF, from WAN to LAN, from laboratory to outdoors. For the latter usage, the IP67 version of the SC-RJ is recommended. R&M has released a white paper covering the SC-RJ («SC-RJ – Reliability for every Category»).</p>
	<p>SC Simplex, Duplex 2.5 mm MMF, SMF PC, APC Flangeless, Screwable</p>	<p>IEC 61754-4</p>	<p>This type of connector with a quadratic design and push/pull system (SC stands for Square Connector or Subscriber Connector). The compact design of the SC allows for a high packing density. It can be combined to duplex and multiplex connections. Although among the oldest connectors, it has excellent properties. To this day it is the most important WAN connector world-wide, thanks to excellent optical properties. SC is also wide-spread in a duplex version, particularly in local area networks.</p>
	<p>MPO MMF, SMF PC, APC</p>	<p>IEC 61754-7</p>	<p>The MPO (multi path push-on) coupler is simply a vessel to hold the MPO connectors as they mate directly to each other without requirement for ferrules. The coupler is distinctive due to its compact design and simple handling, but has disadvantages in optical performance and reliability.</p>

Fiber adapter types – part 2

3. Pre-installation

Approved in March 2007, the standard IEC 61753 describes application-oriented grades for connection elements in fiber-optic networks (see Tables below). The clear identification according to grades and the test method required by the IEC help planners and those responsible for networks during the needs-based selection of plug-in connectors, patch cables, and pigtails. Data centers and telecommunications companies can determine the fiber-optic assortment according to usage and make faster and more targeted purchasing decisions. They also avoid

the purchase of over-specified products which in service potentially do not deliver the expected loss values. The current requirements catalogue is based in part on IEC 61753. This standard defines loss values. Additionally, the standards IEC 61755-3-1 and IEC 61755-3-2 play a role. They define geometric parameters for fiber-optic plug-in connectors. The interaction of these three standards creates the basis for the compatibility of fiber-optic plug-in connectors from different manufacturers and for the determination of manufacturer-neutral loss values.

Performance according IEC 61753-1 (IL)			
Connection type	Insertion loss (IL) typical value	Insertion loss (IL) 97%	
Singlemode			
Grade A*	≤ 0.07 dB	≤ 0.15 dB	
Grade B	≤ 0.12 dB	≤ 0.25 dB	
Grade C	≤ 0.25 dB	≤ 0.50 dB	
Grade D	≤ 0.50 dB	≤ 1 dB	

Connection type	Insertion loss (IL) typical value	Insertion loss (IL) 95%	Insertion loss (IL) 100%
Multimode			
Grade Am*	≤ 0.10 dB	≤ 0.25 dB	≤ 0.50 dB
Grade Bm*	≤ 0.15 dB	≤ 0.15 dB	≤ 0.25 dB

IL Grades according IEC 61753-1

Grade-A* is not fully defined in IEC 61753-1
Grade-Am*/Bm* is not fully defined in IEC 61753-1

Performance gemäss IEC 61753-1 (RL)	
Connection type	Return loss (RL)
Grade 1	≥ 60dB mated ≥ 55dB unmated
Grade 2	≥ 45dB
Grade 3	≥ 35dB
Grade 4	≥ 26dB
Grade 5	≥ 20dB

RL Grade according IEC 61752-1

Overview of performance criteria of the new performances grades for data transmission in fiber-optic connections according to IEC 61753.

Theoretically, the IL grades (A to D) can be mixed at will with RL grades. However, a Grade A/4 would not make sense, and for this reason the following common combinations have established themselves. Those in brackets can be possible but are not recommended:

	Grade 1	Grade 2	Grade 3	Grade 4
Connector Grade A	✓	✓	✗	✗
Connector Grade B	✓	✓	✗	✗
Connector Grade C	✓	✓	✗	✗
Connector Grade D	✗	(✓)	✓	(✓)
Connector Grade M	✗	✗	✗	✓

FO connector IL vs RL

Plugs and adapters are color-coded. The color coding is used to differentiate between fiber types and grinding shapes. MMF PC plugs and adapters are generally beige, SMF PC plugs and adapters have a blue housing color and all APC plugs and adapters are green.

Fiber cable standards

The standards describe 5 different categories of fiber: OM3, OM4, OM5, OS2, OS1a

ISO 11801-1 values	Multimode				Singlemode					
	OM3 & OM4		OM5		OS1a			OS2		
Wavelength (nm)	850	1300	850	1300	1310	1383	1550	1310	1383	1550
Cable attenuation (dB/km)	3.5	1.5	3.0	1.5	1.0	1.0	1.0	0.4	0.4	0.4

ISO11801-1 cable attenuation

3. Pre-installation

R&Mfreenet figures	Color	Cable Attenuation dB/km		Overfilled launch bandwidth MHz x KM	Overfilled launch bandwidth MHz x KM
Wavelength MMF Wavelength SMF		850 nm 1310 nm	1300 nm 1550 nm	850 nm 1300 nm 953 nm	850 nm 953 nm
OM3	Aqua	≤ 3.5	≤ 1.5	≥ 1500 ≥ 500	≥ 2000
OM4	Magenta	≤ 3.5	≤ 1.5	≥ 3500 ≥ 500	≥ 4700
OM5	Lime green	≤ 3.0	≤ 1.5	≥ 3500 ≥ 500 ≥ 1850	≥ 4700 ≥ 2470
OS2 G.652	Yellow	≤ 0.4	≤ 0.25		
OS2 G.657	Yellow	≤ 0.4	≤ 0.25		

R&Mfreenet FO cable loss

Each of these fiber types can be used in a cable with a different cable structure. The structure is described by the designation according to DIN-VDE 0888. The first significant difference is the use indoors or outdoors or with universal cables for both areas. We also differentiate between loose tube, mini-breakout and breakout cables. With the loose tube cable, up to 24 fibers (with 250µm primary protection) are guided in a central tube and surrounded with strain relief and sheathing. If there are more fibers,

several tubes are stranded around a central tension element. With mini-breakout cables, the fibers (900µm buffer) are surrounded by strain relief elements and a sheath. Direct connector installation is possible in certain installations. The breakout cable consists of single simplex cables under a common jacket. Connectors can be mounted on these cables with strain relief. [Table «Fiber cable types»](#) lists the R&Mfreenet installation cable portfolio.

Use	Indoor		In-/Outdoor		Outdoor				
	Breakout	Mini-Breakout	Central Loose Tube	Stranded Loose Tube	Central Loose Tube	Stranded Loose Tube	Central Loose Tube	Stranded Loose Tube	Stranded Loose Tube
Cable description DIN-VDE 0888	I-V(ZN) HH	I-V(ZN) BH	I/A- DQ(ZN) BH	I/A- DQ(ZN) BH	A- DQ(ZN) B2Y	A- DQ(ZN) B2Y	A- D(ZN) W2Y	A- DF(ZN) 2YW 2Y	A- DF(ZN) YQ(ZN) 2Y
Fiber count	8-24	4-24	4-24	12-144	4-24	12-144	6-24	12-96	12-96
Outer sheath	FireRes® LSZH	FireBur® LSZH	FireBur® LSZH	FireBur® LSZH	LLDPE	MDPE	MDPE	MDPE	HDPE
Sheath colour	Green	Green	Green	Green	Black	Black	Black	Black	Black
Armouring	Aramid	Glass yarn	Glass yarn	Glass yarn	Glass yarn	Glass yarn	Corru- gated steel	Corru- gated steel	Aramid
Rodent protection	-	+	+	+	++	++	+++	+++	-
Tertiary cabling	✓	✓							
Building BB		✓	✓	✓					
Campus BB					✓	✓			
WAN							✓	✓	✓
Trunking	✓	✓							
Ducts, Trays	✓	✓	✓	✓					
Building riser		✓	✓	✓					
Raised floor		✓	✓	✓					
Empty tube	✓	✓	✓		✓				
Ducts				✓	✓	✓	✓	✓	
Directly in ground							✓	✓	
Blowing					✓	✓	✓	✓	
On site termination	✓	✓							
Splicing		✓	✓	✓	✓	✓	✓	✓	✓
VARIOline			✓		✓				

Fiber cable types

3. Pre-installation

Fiber optic cable construction and properties

The cable designation varies from manufacturer to manufacturer. In most cases, however, the cables have an imprint that describes how many fibers and which fiber type the cable contains.

- Single-mode indoor cables are green, yellow or black
- Multimode indoor cables are usually colored according to the OM class. OM3 aqua, OM4 magenta, OM5 lime green
- Outdoor cables are usually black, with two orange markings on the outer sheath and relatively stiff
- Examples for printed cable identifications: 12x9/125, 12x9/125 OS2, 12x50, OM3, OM4, OM5
- The first number describes the number of fibers, the second the fiber type, the third identifier the class

R&Mfreenet solution	Cable construction
Duplex Cable Figure 8	<ol style="list-style-type: none"> 1. Fiber 9, 50, 62.5 / 125 μm 2. Cladding 250μm / Buffer 900μm 3. Strain relief (Aramid) 4. Outer sheath
Duplex Cable Figure 0	<ol style="list-style-type: none"> 1. Fiber 9, 50, 62.5 / 125 μm 2. Cladding 250μm / Buffer 900μm 3. Strain relief (Aramid) 4. Sheath 5. Outer sheath
Breakout Cable	<ol style="list-style-type: none"> 1. Fiber 9, 50, 62.5 / 125 μm 2. Cladding 250μm / Buffer 900μm 3. Strain relief (Aramid) 4. Sheath 5. Central strength element 6. Outer sheath
Mini Breakout & Mini Core Cable	<ol style="list-style-type: none"> 1. Fiber 9, 50, 62.5 / 125 μm 2. Cladding 250μm Buffer 900μm (with Minibreakout) 3. Strain relief (Aramid) 4. Sheath (Mini core cable also with double outer sheath available)

Fiber cable construction - part 1

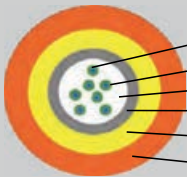
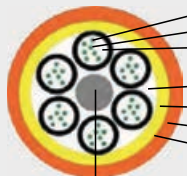
R&Mfreenet solution	Cable construction	
Loose tube Cable		<ol style="list-style-type: none"> 1. Fiber 9, 50, 62.5 / 125 μm 2. Cladding 250 μm 3. Gel filling 4. Loose tube 5. Rodent protection / filling material 6. Outer sheath
Stranded Loose tube cable		<ol style="list-style-type: none"> 1. Fiber 9, 50, 62.5 / 125 μm 2. Cladding 250 μm 3. Gel filling 4. Loose tube 5. Rodent protection / filling material 6. Outer sheath 7. Steel armouring (optional) 8. Central strength member

Fiber cable construction - part 2

There is a very large variety of fiber optic cables available on the market, therefore not all cable types are reproduced here. However, the most common cables are shown above and cover most applications.



030.5693

3. Pre-installation

Sample calculations for installed fiber optic links

LAN Cabling

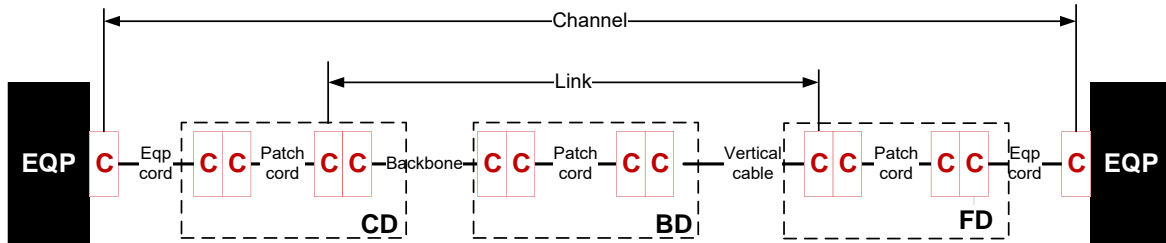

FO sample calculation LAN

The link above is representation of a central CD with the LAN cabling going to a BD and patch through to a FD, where the access switch is located. The cabling is done with 400m OM3 grade cables and connectors.

If the generic standard values for the connector and cable were to be used, a link loss calculation of 0.75dB per adapter and 3.5dB/km for the cable, a total loss of 4.5dB of connectors and $3.5\text{dB/km} * 0.4\text{km} = 1.4\text{dB}$ loss of cable would generate a total loss of 5.9dB would be just enough to run 100Base-FX (See IEEE applications supported MMF (ISO/IEC 11801-1)). In order to run 10G, SMF fiber and transievers would have to be installed.

Data Center

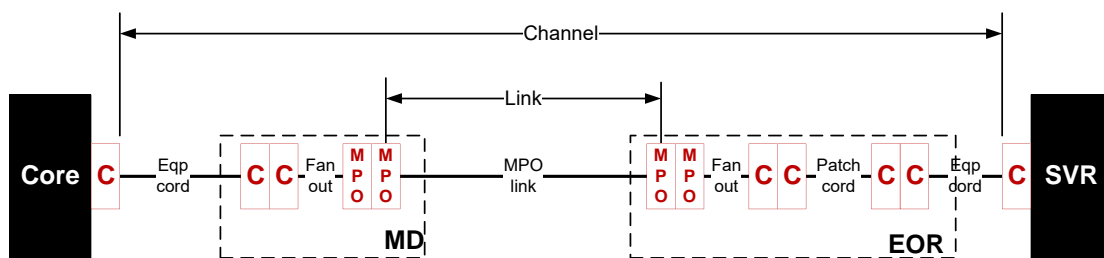

FO sample Calculation DC

The above example shows a switch link from the server to an end of row configuration with LC connectors and an MPO link between an EOR and a main distributor of 150m using OM4 cable.

According the generic standards a connector loss of 0.75dB per connector and a cable attenuation of 3.5dB/km would give $5 \text{ [LC, MPO, MPO, LC, LC]} * 0.75\text{dB}$ equalling 3.75dB total connector loss. $3.5\text{dB/km} * 0.15\text{km} = 0.525\text{dB}$ cable loss. The total channel loss is 4.275dB, which is too high to run 10GBASE or 1000BASE applications.

3.3.2 Channel restrictions for fiber optic cable installations

The following figures represent the applicable models for fiber optic horizontal and backbone cabling. It is not required to have transmission equipment between the backbone vertical cabling and the horizontal cabling to the TO, resulting in combined backbone/horizontal connection models as shown here.

In order to accommodate increase quantities of mated connections and splices used within a channel of a given class, the total length of the channel may have to be reduced to accommodate the additional attenuation.

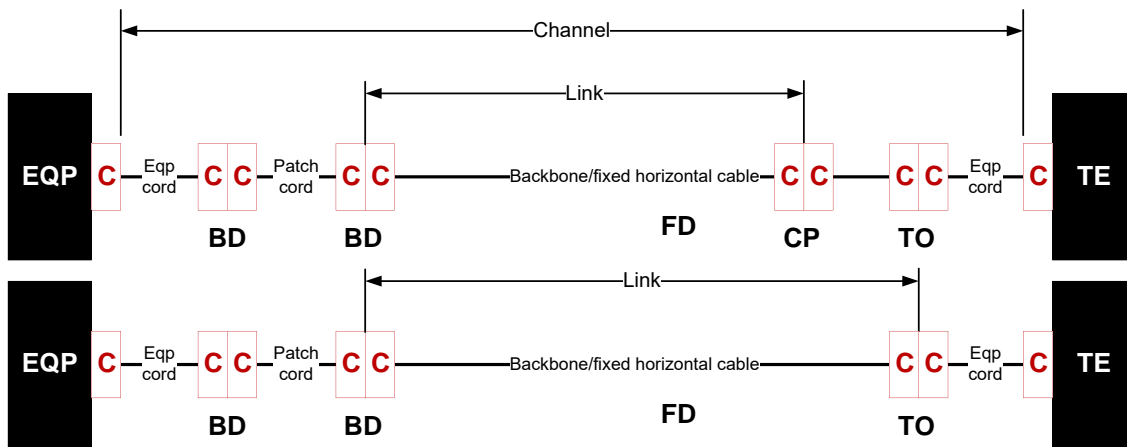

FO 3 Connector direct combined

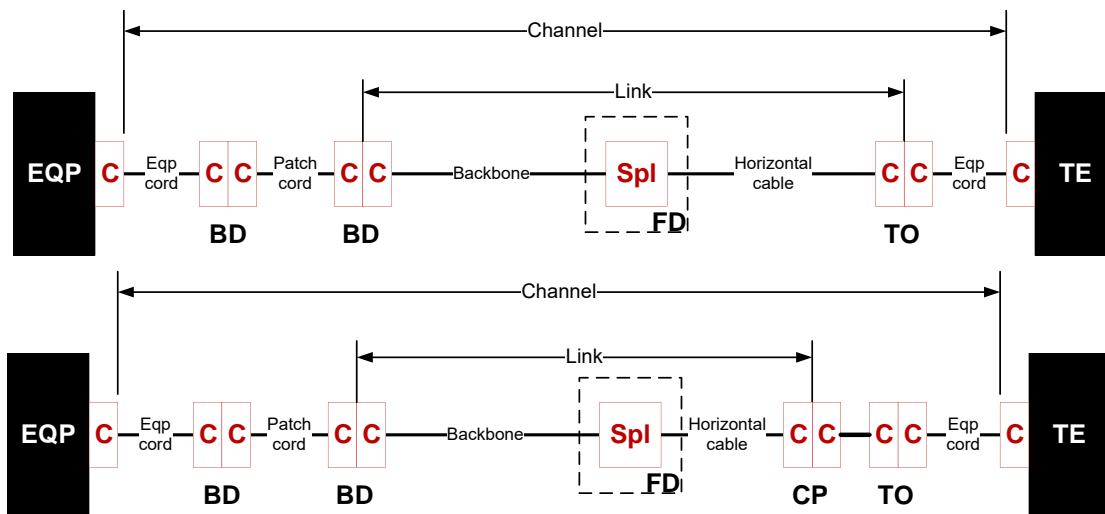

FO 4 connector combined splice

3. Pre-installation

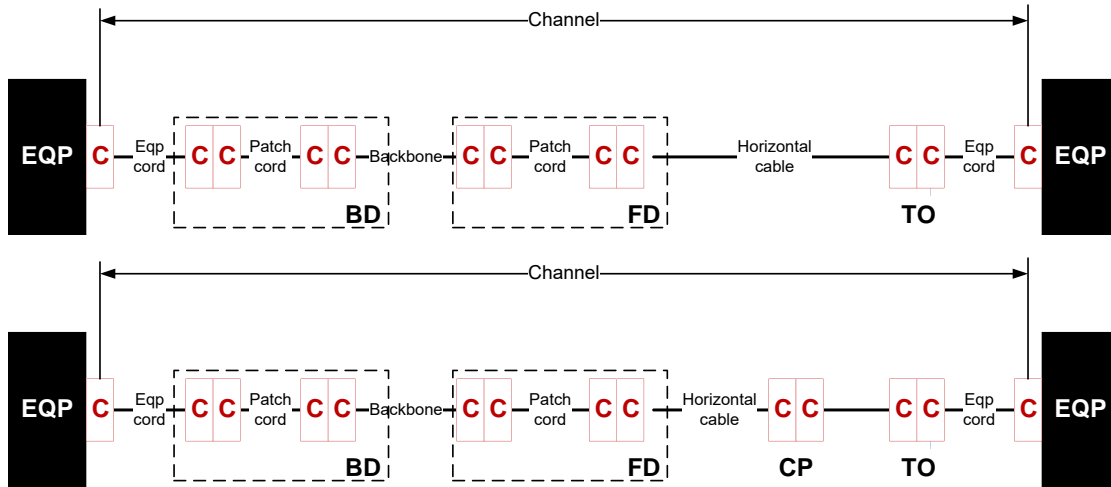

FO 5 connector direct combined

3.3.3 Creating a passive optical LAN network (POLAN)

Introduction

Installing passive optical cabling in an office cabling environment can provide certain advantages and it is supported by current standards and by R&Mfree-net products. POLAN are emerging in markets where there is a need to conserve space, reduce material costs and be energy efficient. It combines the GPON technology that is known in the FTTx business with the LAN architecture of office cabling.

This solution's only active components are the Optical network Line Terminal (OLT) in the MD/BD and the Optical Network Termination (ONT) at the work area, the connection in between has no active components, just passive single-mode fiber optic cabling, called optical distribution network (ODN). As with a generic tree design,

a high reliability and redundancy in the network can be achieved. Added advantage is that by using an all optical fiber network, EMC protection for the data cabling becomes a non-issue, which could be beneficial from a security point of view. The bending radius, size and weight of FO cable also attribute to the ease, flexibility and speed of installation. However, it is an application dependent solution.

In order to comply with ISO, EN and TIA standards a minimum of 2 connections per workspace needs to be foreseen. All other requirements fall under the general standard configurations. The figure below simulates how a PON infrastructure conforms to the ISO layout.

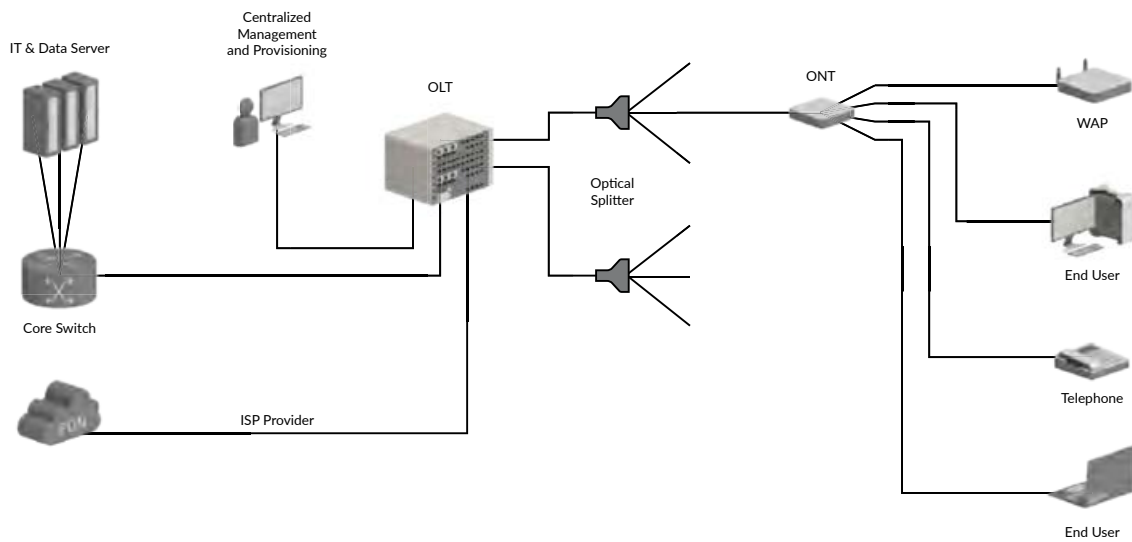

Principal scheme for POLAN

3. Pre-installation

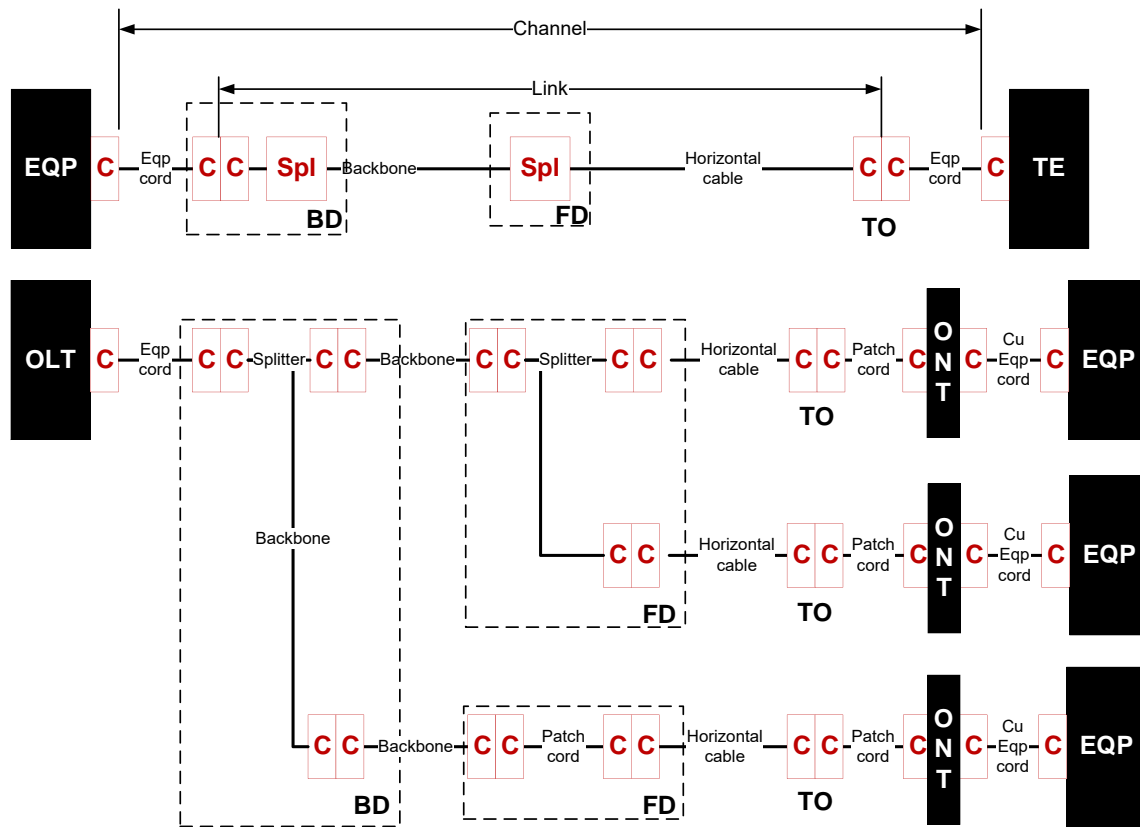

POLAN sample configuration

The optical channel budget will be a bit different as we are using a different network protocol, the current common protocols are EPON 1Gbps and 10Gbps, and the table below provides the different power budgets for each application.

IEEE 802.3	Upstream (1310 nm) Channel loss (dB)	Upstream Line Rate (Gbit/s)	Downstream (1550nm) Channel loss (dB)	Downstream Line Rate (Gbit/s)
1000BASE PRX10 10GBASE PR10	≤20.00	10.3125 10.3125	≤29.50	1.25 10.3125
1000BASE PRX20 10GBASE PR20	≤24.00	10.3125 10.3125	≤23.50	1.25 10.3125
1000BASE PRX20 10GBASE PR20	≤29.00	10.3125 10.3125	≤28.50	1.25 10.3125
1000BASE PRX40 10GBASE PR40	≤33.00	10.3125 10.3125	≤32.50	1.25 10.3125

IEEE802.3 GPON power budget

As well as the normal connector and cable losses, as described in chapter 3.3.1, there are also the splitter losses to consider and these losses depend on the quantity of outputs of the splitter. The table below provides an overview of the R&M splitter module losses.

R&M Performance Specifications	1x4	1x8	1x16	1x32	1x64
Max IL @ 1310nm/(1490)1550nm (dB)	≤ 7.00	≤ 10.40	≤ 13.50	≤ 17.00	≤ 20.50
Uniformity	≤ 0.80	≤ 1.00	≤ 1.30	≤ 1.50	≤ 1.80

R&M splitter performance

3. Pre-installation

Sample Calculation

This example highlights a building of four floors, with four floor distributors that each serve 28 workplaces. It can be calculated if POLAN architecture could be possible.

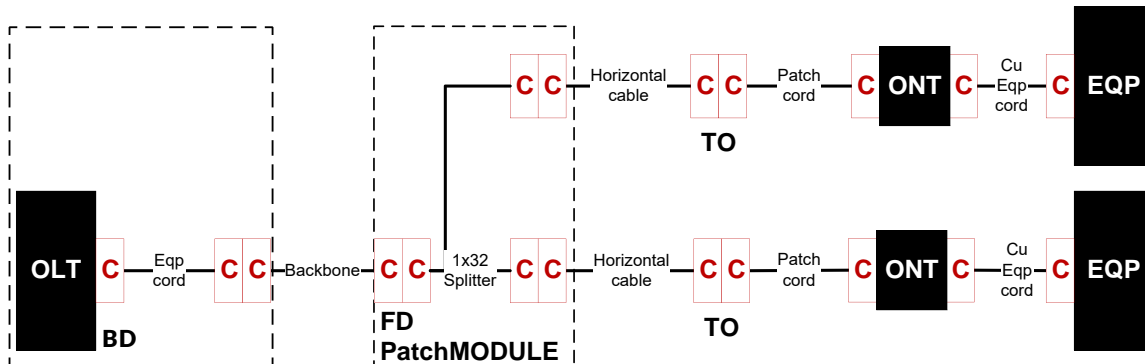

POLAN calculation sample

For each splitter, there is the loss of the entry and exit adapters plus the loss of the splitting technology. All R&M splitters use standard grade B connectors. In this example, there is 1 adapter in BD, 2 in the FDs and 1 at the OTO (optical terminal outlet), which is a total of 4. By using the GOF calculator, it can be seen that the combined loss of the connectors will be below 1.00dB. Additionally there is 17dB for the splitter in the FD. Therefore the total calculated loss on the link is 18.00dB.

If the 1000BASE-PX10 protocol were to be used for the OLT, then a maximum channel loss of 20dB @1310nm and 19.5dB @1550nm would be permissible, which would leave 2dB and 1.5dB margin respectively for reserve cable loss. Therefore with losses of 0.39dB/km @ 1310nm and 0.25dB/km @1550nm, this means a maximum allowance of 5km @ 1310nm and 6km @ 1550nm.



Products for the realization of a POLAN

3. Pre-installation

3.3.4 Planning the polarity of your fiber network

Optical fiber patch cord

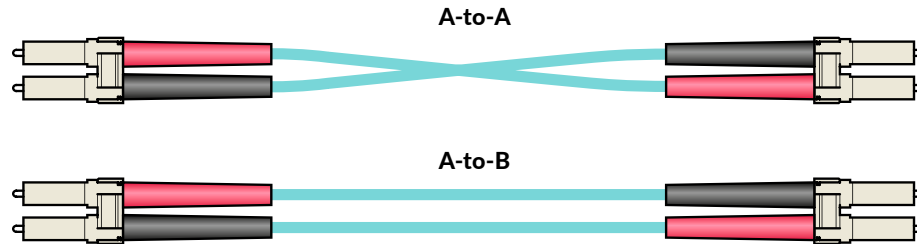

OF patch cord polarity

FO installation cable color coding

Fiber No.	IEC 60794-2	TIA 598-B (MPO)	DIN VDE 0888	Swisscom code (CH)
1	Blue	Blue	Red	Red
2	Yellow	Orange	Green	Green
3	Red	Green	Blue	Yellow
4	White	Brown	Yellow	Blue
5	Green	Slate	White	White
6	Violet	White	Slate	Violet
7	Orange	Red	Brown	Orange
8	Slate	Black	Violet	Black
9	Aqua	Yellow	Aqua	Slate
10	Black	Violet	Black	Brown
11	Brown	Rose	Orange	Rose
12	Rose	Aqua	Rose	Aqua

FO installation cable color codes

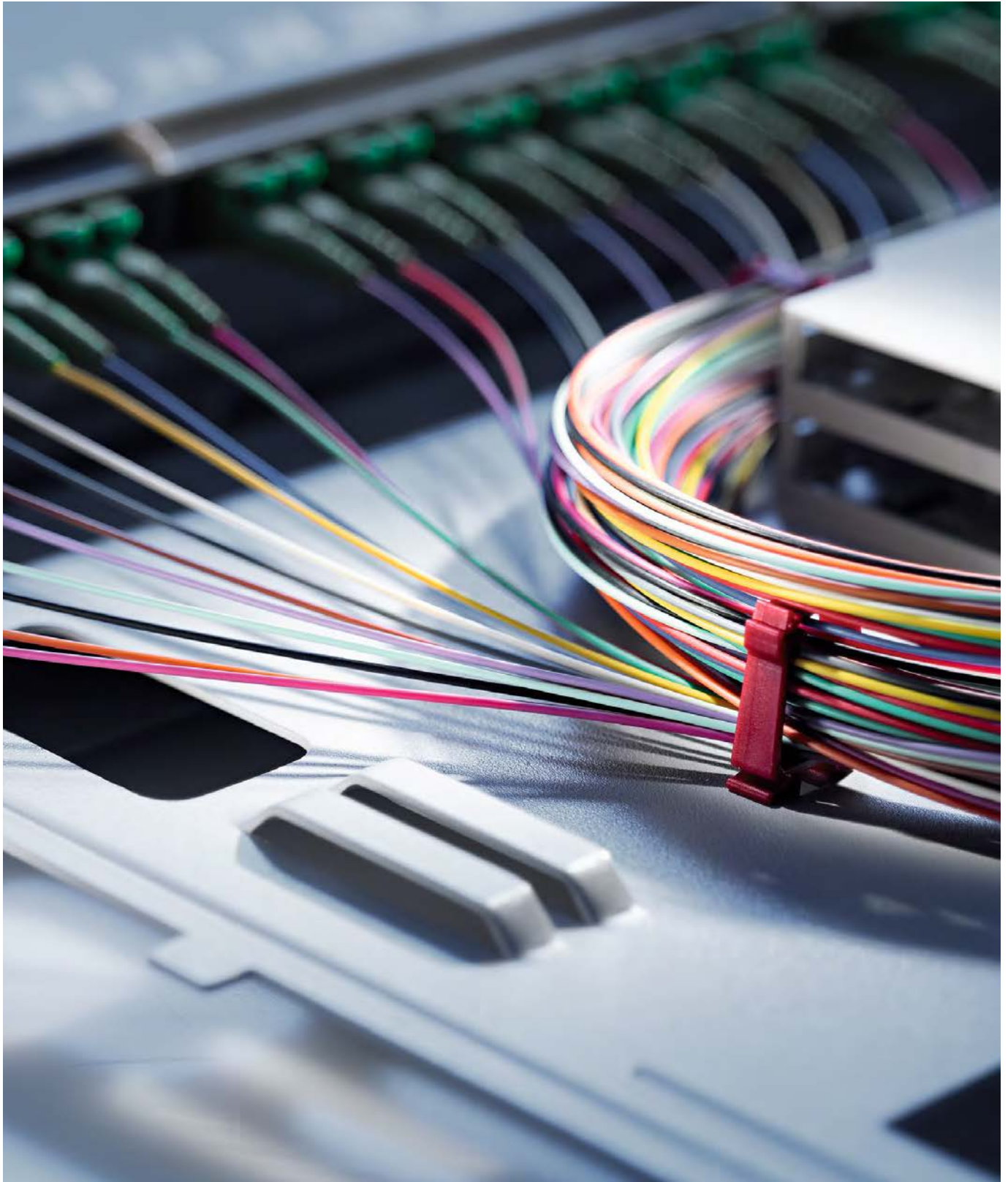

3. Pre-installation

Standard link polarity

There are 2 possible ways of planning the polarity of your network; both systems have their disadvantages and advantages. It is very important to have cleared the polarity concept with the end customer as they will be the one that will be using the network.

Everything Crossed

Most commonly, standard fiber patch cords are in a crossed orientation (i.e. A connects to B and B connects to A) to ensure that the transmit port is connected to the receive port on the other end. When the fixed link is crossed it ensures that the transmit port is connected to the receive port, by having an odd number of links (a patch cord at each end plus the fixed link). Here, the responsibility lies with the installer to ensure appropriate polarity of the fixed link to enable this duplex configuration.

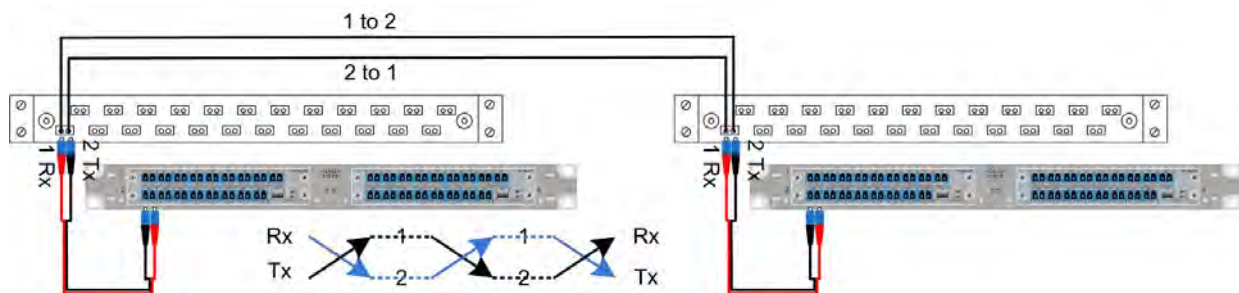

FO crossed backbone polarity

Advantage:

- No need to change the duplex patch cords
- Same polarity configuration if mixed with MPO/cassette links in method B & S

Disadvantage:

- Coordination during fiber terminations which side has the polarity change
- Difficulties in polarity assurance with even amount of links, e.g. CP/ZD
- The polarity concept will have an influence on how preterminated links and/or the pigtail configuration in a patch panel is ordered

Fixed Link Straight

In this case the fixed link is installed one-to-one according to the color code required. So one of the pairs in one of the patch cords must be crossed in order to connect Tx to Rx. Here the responsibility lies with the IT administrator to ensure correct polarity

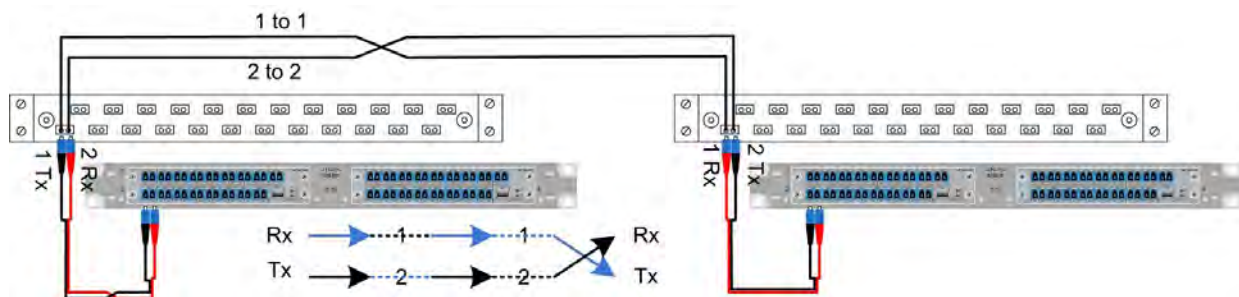

FO straight backbone polarity

Advantage:

- The fixed cable can be terminated according to the same color code on both sides

Disadvantage:

- Strict procedures to be written to define where the technician needs to change the polarity of the patch cord
- Difficulties in polarity assurance with multiple links, e.g. CP/ZD or 2 links
- Same polarity when combining with MPO/cassette links in method A.

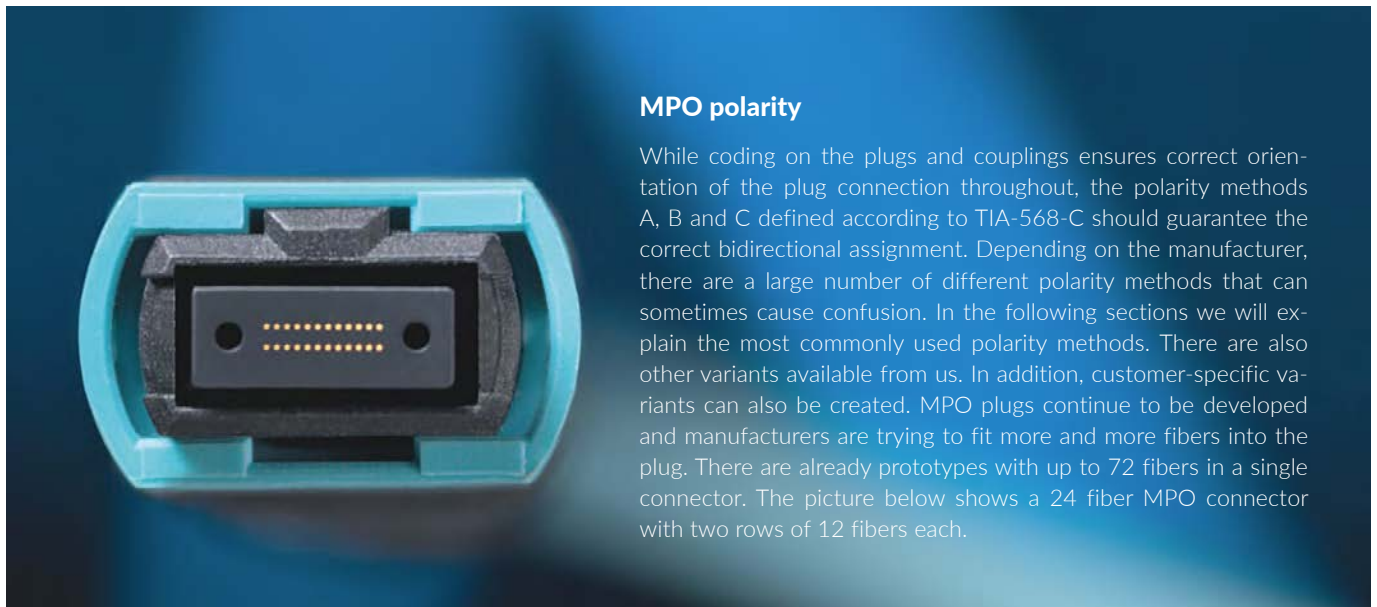

MPO polarity

While coding on the plugs and couplings ensures correct orientation of the plug connection throughout, the polarity methods A, B and C defined according to TIA-568-C should guarantee the correct bidirectional assignment. Depending on the manufacturer, there are a large number of different polarity methods that can sometimes cause confusion. In the following sections we will explain the most commonly used polarity methods. There are also other variants available from us. In addition, customer-specific variants can also be created. MPO plugs continue to be developed and manufacturers are trying to fit more and more fibers into the plug. There are already prototypes with up to 72 fibers in a single connector. The picture below shows a 24 fiber MPO connector with two rows of 12 fibers each.

3. Pre-installation

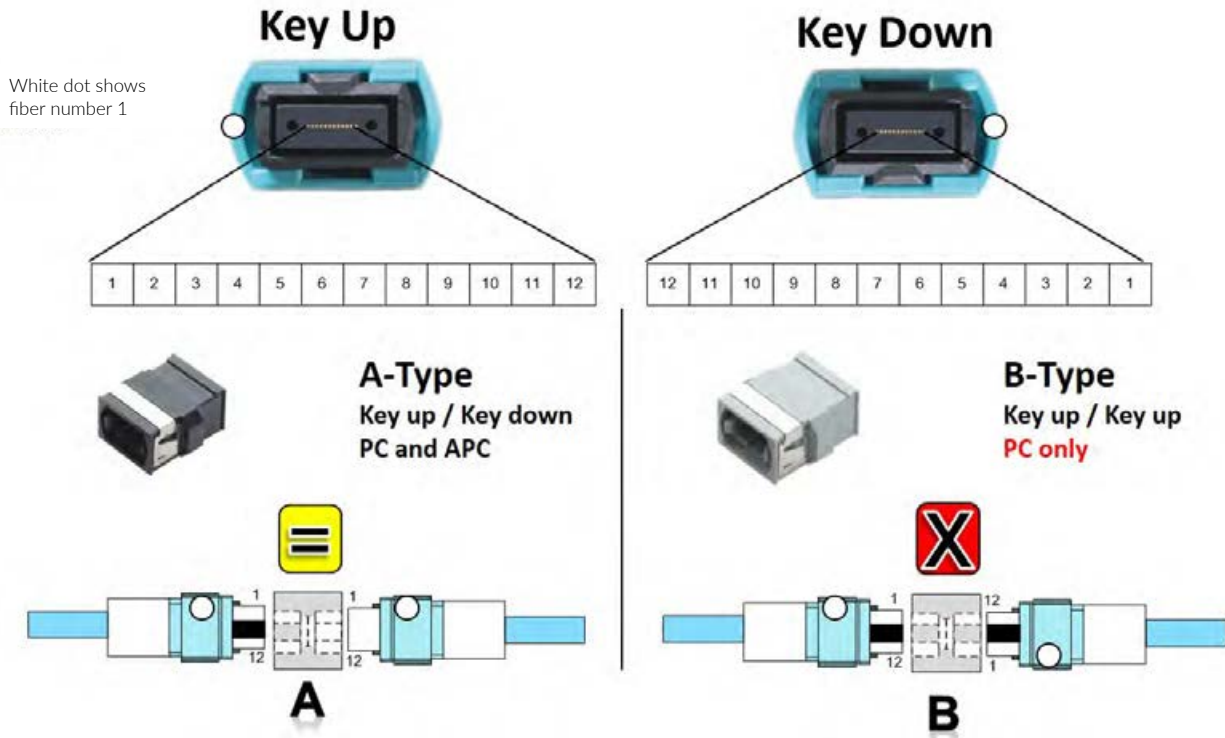

Key Up and Key Down

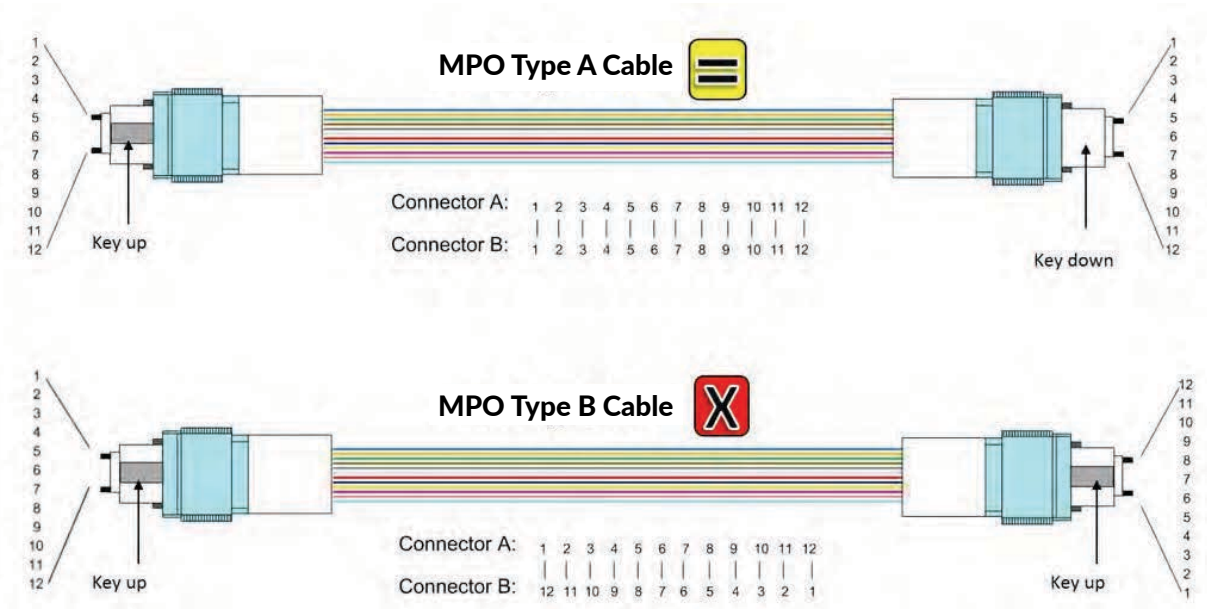

MPO Type A and MPO Type B Cables

Method A

Method A uses straight-through type A trunks (pin1 to pin1) and type A (key-up to key-down) MPO adapters. On one end of the link is a straight-through patch cord (A-to-B), on the other end is a cross-over patch cord (A-to-A). A pair-wise flip is done on the patch end. Note that only one A-to-A patch cord may be used for each link. Here the responsibility lies with the IT Admin to ensure correct polarity. MPO components from R&M have been available for Method A since 2007. It can be implemented quite easily, because e.g. just one cassette type is needed, and it is probably the most widespread method.

Duplex

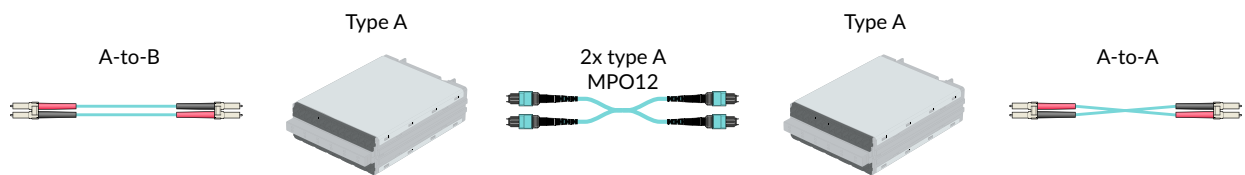

MPO polarity method A components

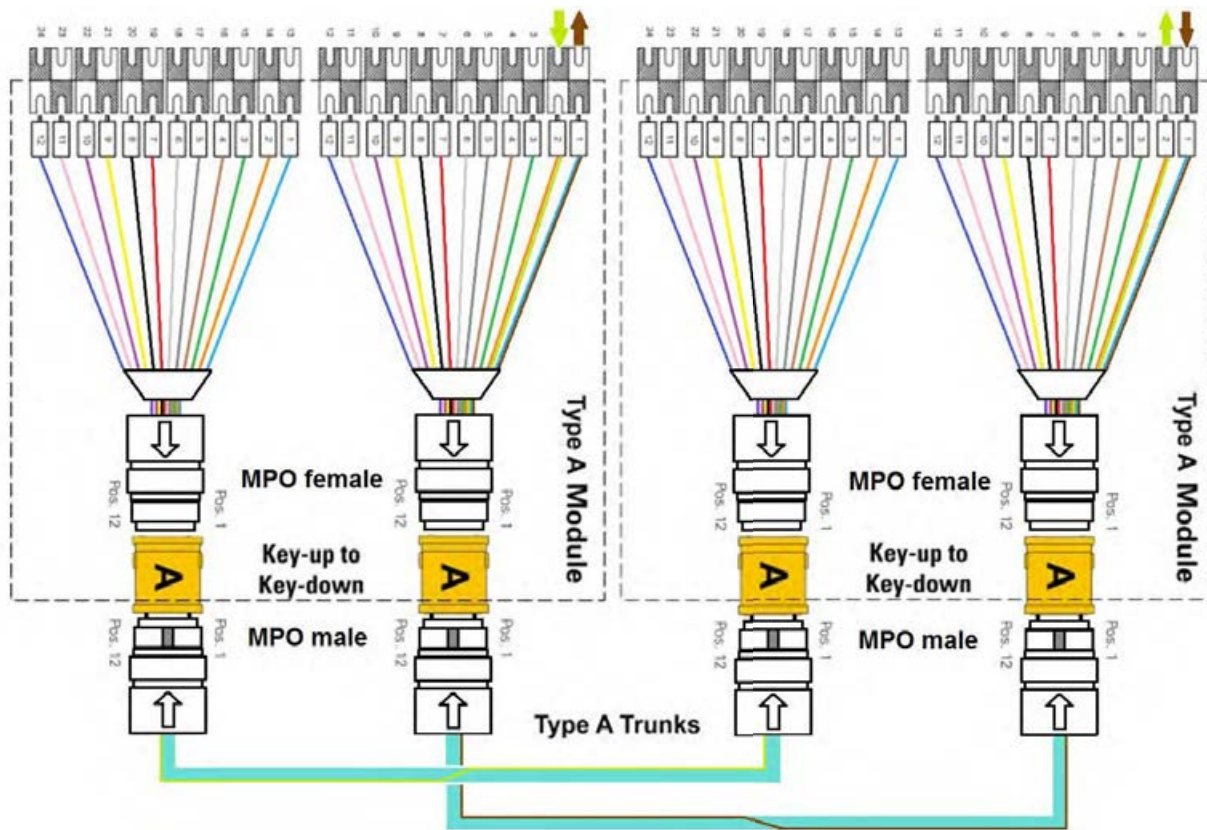

MPO polarity method A fan-out

3. Pre-installation

Parallel

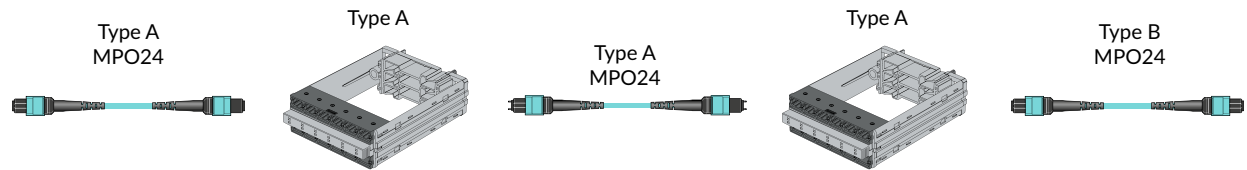

MPO polarity method A 40/100G

Method S

Method S (a designation defined by R&M) has been available since 2013. It requires just one type of patch cord (A-to-B). The crossover of the fibers for duplex signal transmission (10 GBASE-SR) takes place in the pre-assembled cassette. The connectivity diagram for the trunk cable and patch cord or the light guidance remains the same all the time, even for parallel transmission for setting up 40/100 GbE installations. The method S is applicable for MMF and SMF and can be used with Type A and Type B trunks. The twelve LC ports are divided into Tx and Rx so that all Tx fibers are run to a 12-fiber MPO and all Rx fiber to another 12-fiber MPO. These two MPOs can be bundled in an X cable, for example. Type B adapters are installed in the modules. It is therefore impossible to have only a 12 fiber MPO cassette, the minimum fiber count is 24 per cassette. Symmetric cabling for 1G, 10G, 40G and 100G is therefore enabled in collaboration with type of trunks used for the duplex solution. That means capacity can be expanded directly in an uncomplicated and inexpensive manner. In addition, the only thing that has to be done is to replace the cassettes with adapter plates.

Parallel Solution Trunk B

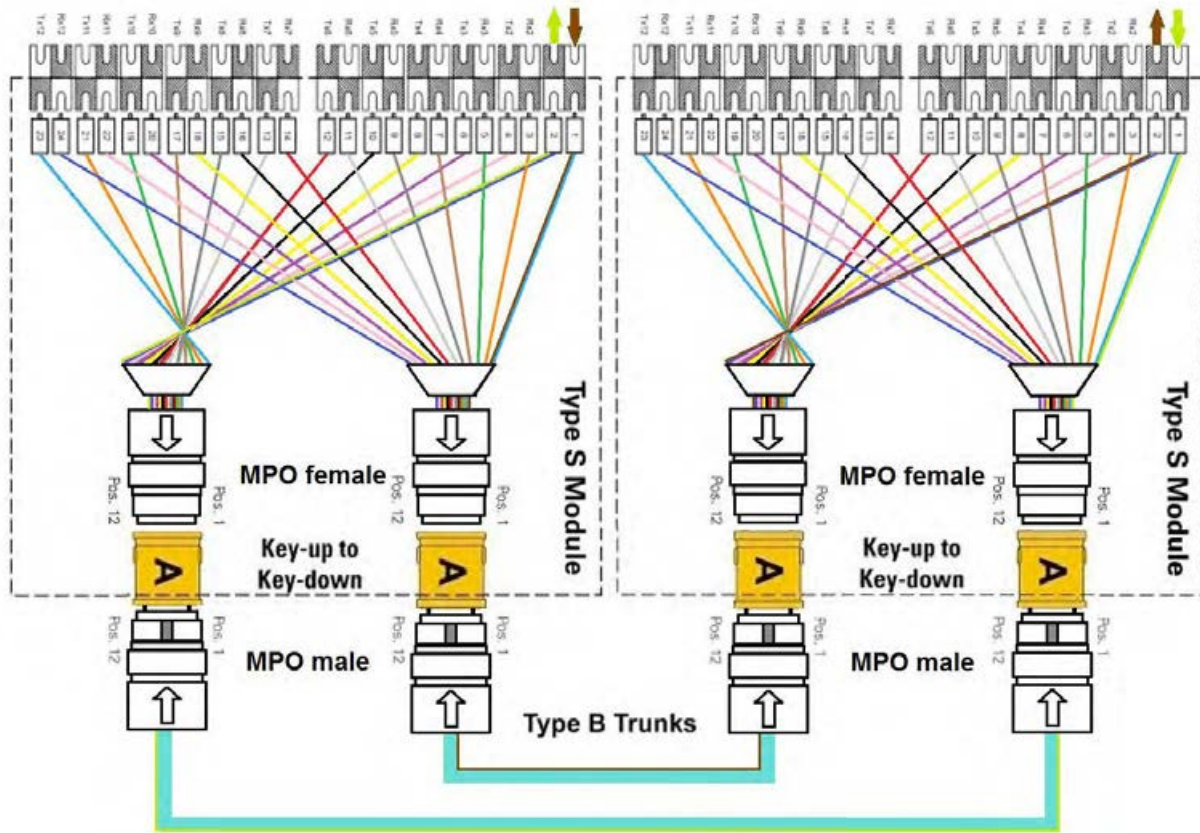

MPO polarity method with R&M fan-out Trunk B

Parallel Solution Trunk B

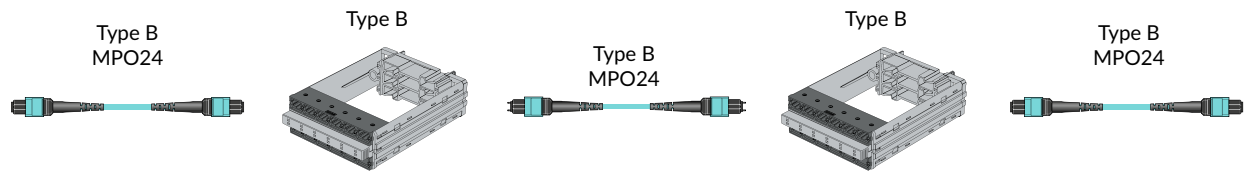

MPO polarity method R&M 40/100G Trunk B

3. Pre-installation

Duplex solution Trunk A

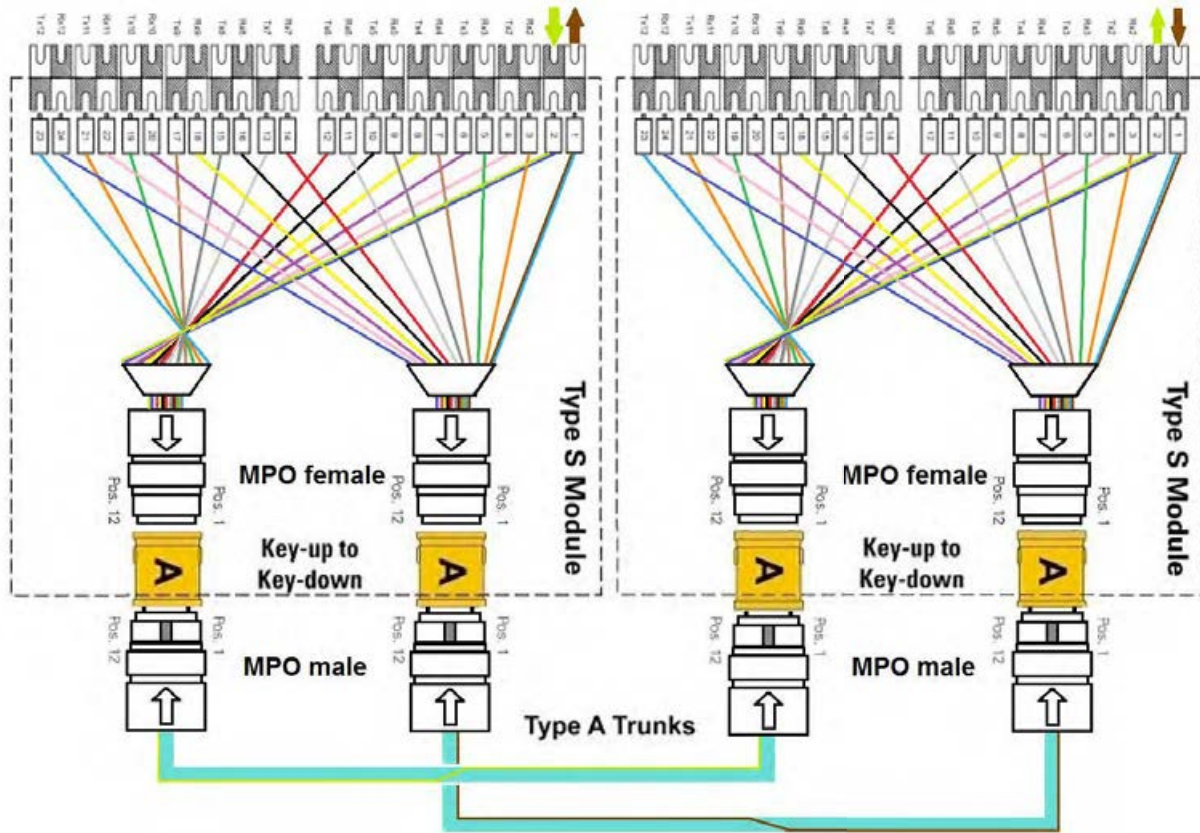

MPO polarity method with R&M fan-out Trunk A

Parallel solution Trunk A

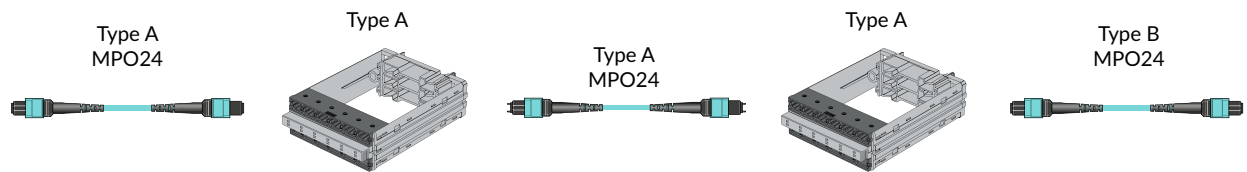

MPO polarity method R&M 40/100G Trunk A

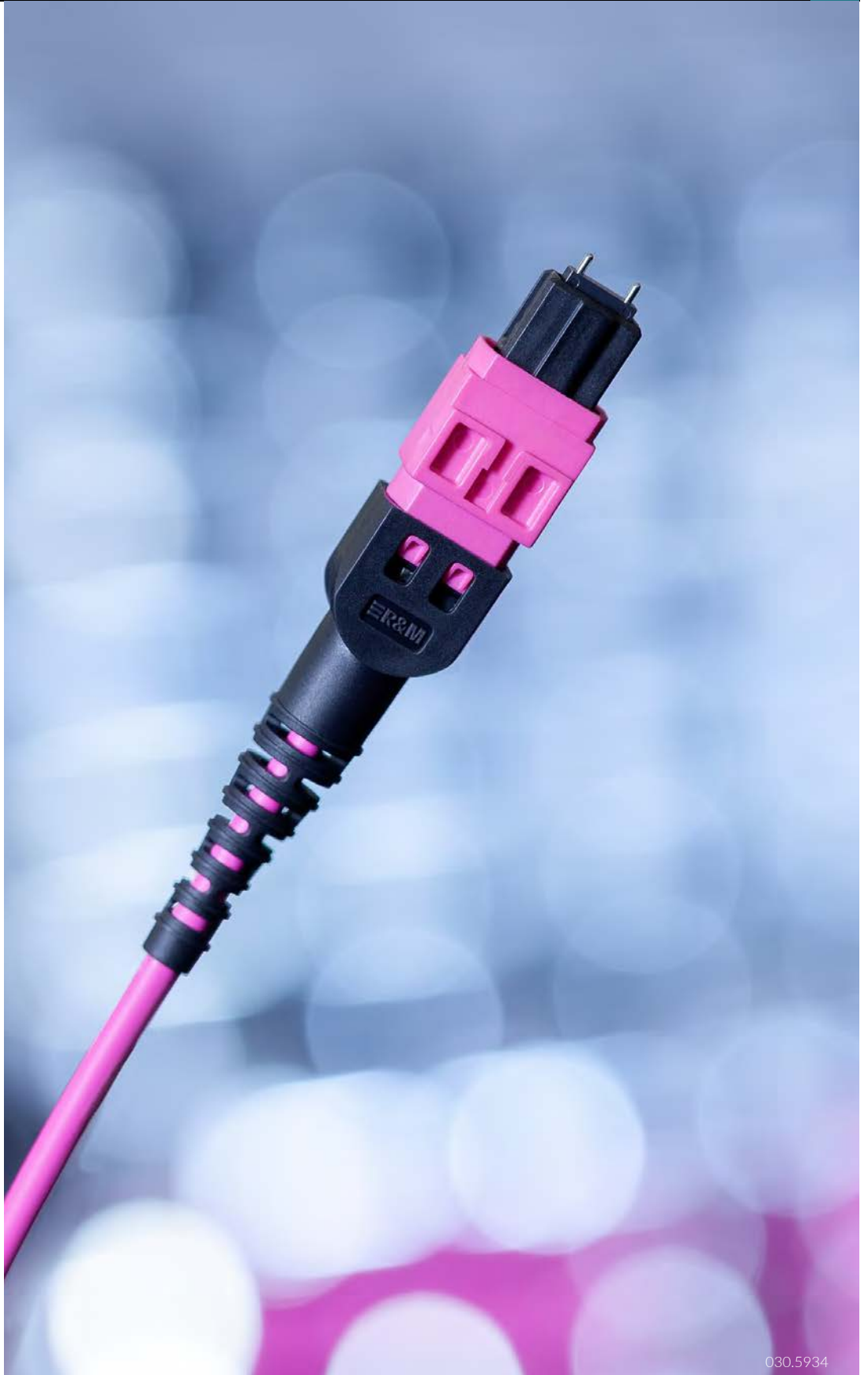

030.5934

4. Installation





4. Installation

4.1 General

4.1.1 Safety

The installer must take all necessary safety precautions, such as wearing protective clothing and goggles and observing warning signs or barriers, to ensure that the required personnel and equipment protection for themselves and third parties is provided.

Applicable national laws and regulations regarding safety must always be observed. In addition to the legal responsibility everyone is also responsible for their own health. Current legislation gives planners responsibility for the project safety, while the building owner is expected to respect the many standards concerning the safety of the building's electrical infrastructure.

4.1.2 Labels and administration

The labeling of components and telecom spaces are mandatory requirement of all the cabling standards. While all cabling standards require identification, labeling and recording of all cabling elements in a database, it is TIA/EIA 606-B that stipulates precise rules on this topic. In ISO/IEC 14763-2 and EN 50174-1 installers are given freedom in how to implement identification, labels and database.

All R&M *freenet* components are designed and supplied with everything the installer requires to implement the standards. However, if an installer wants to adopt a different method, R&M can accept that too, provided the following three conditions are fulfilled:

1. All cabling elements are identified and recorded in the installation database.
2. All cabling elements are labeled in accordance with one of the recognized cabling standards.
3. A cabling system database is set up including all components and their connections.



4.1.3 Storage and transport of installation cable

If the installation cable (copper or fiber) is not used immediately after delivery, it must be stored in a suitable location.

The volume of cabling, equipment racking and technology deliveries will be high during the build-out phase. Delivery of goods-in will require storage in a secure area within the building stack. The cable must be stored in a dry location where it will not be subjected to mechanical damage or harmful climatic



Copper cable stored in good conditions

Any moisture entering reduces the effectiveness of the conductor insulation and increases the risk of corrosion of metallic parts, also water inside the cable can cause the cable sheath to break if the temperature falls below zero degrees. For this reason, cable ends should be protected. Fiber optic cables should be protected with heat shrink cap. When data cables are delivered in winter, cable reels that were exposed to temperatures below zero for a long time should be left to acclimatize in a warmer environment before they are unrolled and installed.

Unloading and transportation of cable should be done in such a way it does not damage the cable or the reel. Do not drop reels from a height as this could give problems with de-reeling and cause damage to the cable. When unloading cable use the lift or a forklift truck to lower the cable drums. When using a forklift, be sure the reel flanges are perpendicular to the forks.

conditions. If possible, the stored material should be kept in its original packing right up to the time of installation. The relatively loose cable construction (generally true of all symmetrical data cables) can cause a slight capillary effect, which can draw moisture into the cable. If water enters in this manner, impedance values of the cable change, which causes the electrical transmission characteristics of the cable to deteriorate.



Copper cable stored in the wrong conditions

Remember that receiving inspection is the first step of the quality process. This inspection should include: cable quantity, part number verification, recording of cable quality traceability identifiers (production lot, batch, production date) and possibly verifying functionality by creating a sample link to be tested according to standards. Remember that before any testing, you should allow two or three days for the cable to relieve the stress of lay down or pulling operation.

4. Installation



Unloading reel with bar



Correct lifting procedure

When rolling reels make sure the road taken does not hold any obstacles that could damage the cable.

4.1.4 Environmental conditions

The following measures will have positive impact on the final testing and warranty hand-over. They will avoid complications and damage to the IT infrastructure during the build and make sure the labor put in the cable installation is not in vein due to neglect of others.

Telecommunications Room (TR) and Equipment Room (ER)

The raised floors in TRs or ERs should be protected from builders work by e.g. floor covering. Access to these rooms will require the provision of a sticky mat, changed frequently and maintained in a continual clean state.

These rooms should have temporary security measures, under lock and key whilst pending completion/commissioning of the final Security platform. It is proposed that a key lock system be established based upon sign-in/sign-out for all hubs, risers and ER spaces. It should be further considered that on-site security will cover these key areas.

Risers and ducts

Access to any IT riser space will require protection. Installed looms of cables are sensitive and have significant program and cost impact through accident, or any intended or non-intended malicious behavior. Appropriate provision for concealing cables away from on-going builders work needs to be considered.

Cleaning

Technology equipment requires an extremely clean working environment at all times. A key consideration to the IT program of work and retaining program is the environmental cleanliness of the spaces where IT works are planned. As such, the following definitions should aid in the development of the program for readiness of the IT works.

- Builders clean – any space ahead of acceptance by IT for works to proceed will require a thorough , Builders Clean'. This means all areas, above floor and sub floor are vacuumed and cleaned of all debris.
- Clinical Clean – TRs/ERs undergo a clean by a specialist contractor to EN ISO 14644/1 Level 8 ahead of any area whereby specialist IT equipment is to be hosted and power activated, the area will be subjected to a clinical clean. This means that the entire area has been subjected to ,white glove' dust cleaning and will pass any particle test of air sampling.

These cleaning definitions typically relate to acceptance of spaces from the fit-out contractor, «Room Ready» is a defined milestone for installation of the IT program of works.

The contractor should incorporate an allowance to conduct numerous shifts of each of these cleaning phases. Any areas not-fit-for purpose will have direct impact on the installation. Cleanliness and environment conditions must be maintained to the highest of standards especially when installing fiber optic components as they are very sensitive to dirt.



4. Installation

4.2 Copper

4.2.1 Cable characteristics

It is very important to install cables carefully to achieve the values specified in the standards.

Symmetrical installation cables are intended to be installed only once. Margins are so tight in today's data cable design that performance deterioration caused by improper installation can already lead to failures during the acceptance tests. The following requirements must therefore, be strictly adhered to when installing a cable.

General

When routing cables in under floor system raceways, care should be taken not to pinch the cables to avoid highly probable damage to the cables. This often occurs when fitting floor plates and causes irreparable damage to installation cables. Avoid coiling cable slack as it can cause return loss reflections which can lead to a fail during acceptance testing.

Avoid laying out (extensively unrolling) the cable before pulling it to prevent third parties from damaging the exposed cable. Remember that symmetrical cables are designed for indoor applications; therefore the cable should always be protected. Unprotected cables are subject to damage.

The cables may not be unrolled over the sides of the reel flanges (This risks twisting the cables. The geometry of the symmetrical pairs is noticeably changed). If dampness or wetness is detected when pulling the cables, the source of the water must be determined and eliminated. All cables that are exposed to water during installation must be replaced.



Cable tensile force

Maximum tensile force during installation – S/FTP	80 N
Maximum tensile force during installation – U/UTP	110 N

Always refer to the relevant data sheet for exact figures.

With special tools it is not possible to exceed a certain pulling force. These tools always assure the quality of the twisted pair cable. In order to further reduce the tensile force in the installation cable when unrolling, it is advisable to assist the unrolling process by turning the reel. That is, whenever possible, the reel should be manually unrolled.

Proper direction



Proper direction for unrolling

Wrong direction

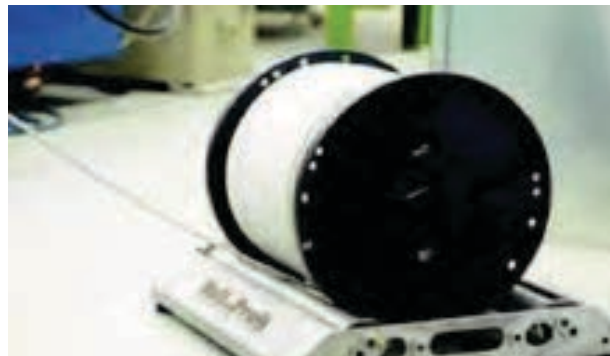

Wrong direction for unrolling

When routing installation cables in vertical shafts or risers, gravity should be used – instead of pulling the cables up the shaft where possible, lower them from above. This avoids unnecessary tensile stress. Nevertheless, this is sometimes neither possible nor practical. If the cables must be pulled upward, adequate installation personnel should be available to safely and carefully pull the cable through all of the levels. When routing installation cables in raceways they should be fastened – use Velcro and avoid plastic straps, fasten the cable after it is sitting in its final position and never bend cable bundle after fasteners are tightened. Ensure that the cable fasteners are not too tight. It should still be possible to turn them slightly and the cable jacket should

maintain its original shape. If the cable fasteners are fixed too tightly, pressure points result, which deteriorates the electrical transmission properties of the data cables.

For vertical installations strain relief is recommended at least every 600mm. Avoid cable bundling or limit the quantity of cables bundled together to reduce the occurrence of alien crosstalk and cable stress when moving or bending, and to make sure the specified bending radii are not exceeded. When pulling the cable, a cable pulling sock should be used.

Note: *Fasten all conductors to the pulling tool and secure with insulation tape.*

4. Installation



Proper vertical riser installation

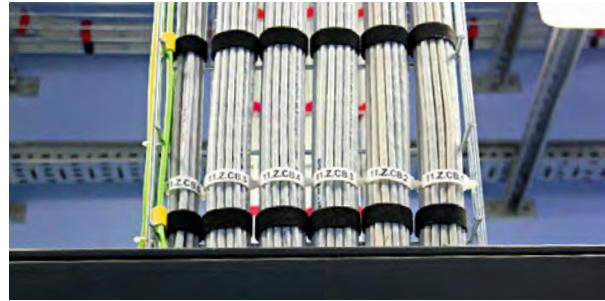

Correct fastening of vertical cables

Cable bending radius

The following bending radii rule of thumb for R&Mfreenet copper installation cables:

Category	Installation	Installed
Cat. 5e	50mm	25 mm
Cat. 6/6 _A	60mm	30 mm
Cat. 7 / 7 _A / 8.1 / 8.2	70mm	35 mm
Real10 U/UTP	70mm	60 mm

Sample copper cabling bending radius

Always refer to the relevant data sheet for exact figures.

When bend radii are too tight, especially in cable installation, they can alter the mechanical structure of the twisted pairs within a cable, and this has a negative effect on the cable's transmission characteristics (mostly NEXT, FEXT and RL).

If cables are routed across any edges where they bend or branch, ensure that the minimum specified bending radius for the respective cable type is maintained when pulling the cable. If cables must be pulled across edges, ensure that the outer cable jacket is not damaged by abrasion or tensile stress. Ensure that the total weight of all installed cables does not damage the installation cables on the bottom.

The use of guides and pulleys is recommended to protect the pulled cables, as well as routing by hand using an additional installer or partially installing step by step.

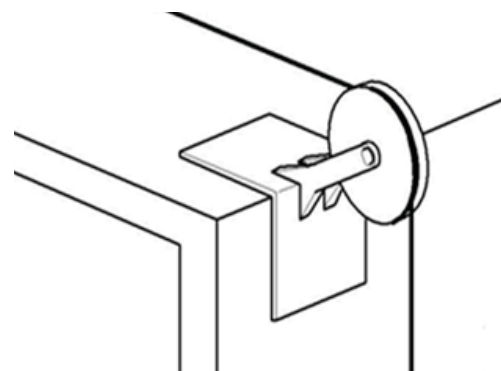

Copper cable installation pulley

Cable management

There are different possibilities for drawing installation cables from their cable entry through the distributor cabinet to the connection modules. It needs to be made certain that the cables are sufficiently tension-relieved and run in a loop, allowing the elements to be taken out easily from the front (cable reserves are used for maintenance or a later upgrade to higher categories).

Proper rack cable management

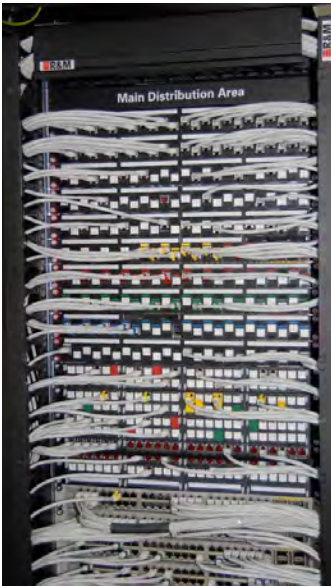

Wrong rack cable management



Cable management examples

4. Installation

4.2.2 Cable preparation

Copper cables should only be prepared and connected using suitable tools. If, for example, a knife or an unsuitable stripping tool is used when stripping the cables, there is a risk that the wires in the cable may be damaged or their insulation cut. If this is the case, it is highly likely that shielding, short-circuits or other sources of error are then caused. It is also important to use a side cutter that allows the wires to be cut cleanly and flush. It should be highlighted that all modules or plugs, regardless of their design, are connected cleanly and carefully.







R&M offers various connection, stripping and auxiliary tools that enable clean stripping and termination of cables and modules.

However, R&M products are also good and easy to process with most conventional tools. However, special care should then be taken to work carefully and cleanly.

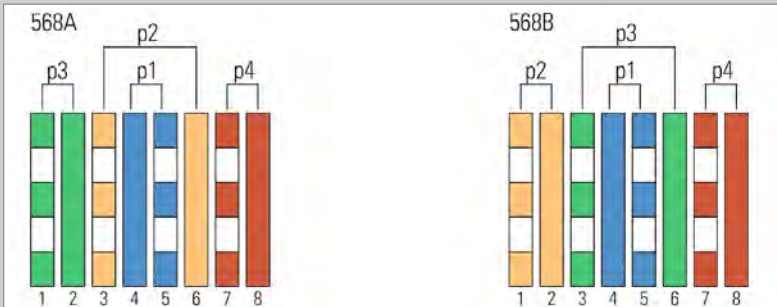

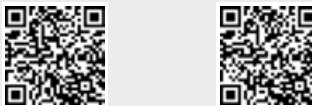
Tools for terminating copper cables

4.2.3 Termination of modules

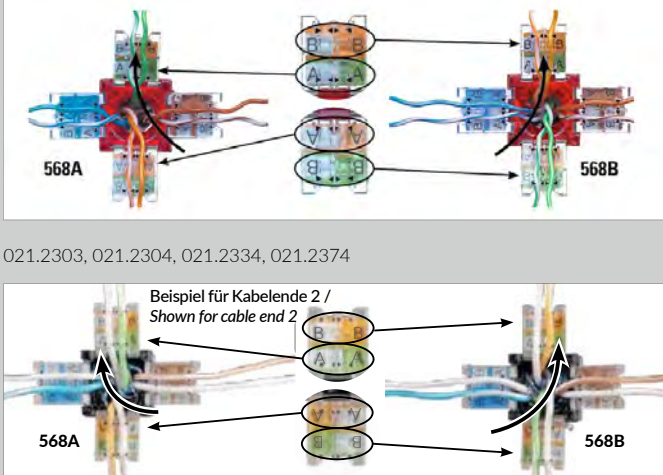
Category	Beschtung
<p>Cat. 5e, Cat. 6</p> <p>According to the types of modules, Cat.5e & Cat.6, different covers can be applied</p>  <p>090.5327, 010.2017</p>	 <p>020.1312</p>
<p>Cat. 6_A EL</p>   <p>090.7180, 090.7179, 090.7571, 090.7569</p>	 <p>Aufdrehen Adernpaar und nach Farbcode einlegen <i>Untwist wire pair and insert color code</i></p> <p>021.3081, 021.3082, 021.3083</p>
<p>Cat. 6_A ISO & Cat. 8.1</p>   <p>030.5527, 030.5971</p>	 <p>021.2303, 021.2304, 021.2334, 021.2374</p> <p>Beispiel für Kabelende 2 / <i>Shown for cable end 2</i></p> <p>030.6041 / 030.6042 / 030.6043 / 030.6044</p>

Termination of modules

4. Installation

4.2.4 Patch cables

Patch cables are increasingly important key factors in reaching the target channel performance. That is why R&M recommends using only patch cables of the highest quality. Patch cables should be replaced after 750 matings. Smaller bending radius than $4 \times D$ is not allowed, kinks and torsion can reduce the performance.

Applying of tensile force is not allowed (maximum of 2N). It is highly recommended to use R&M patch cords with any installed R&M System.

4.2.5 Characteristic problems in generic cabling systems

Cat. 5e/Cat. 6 Module

A major problem source is incorrect termination of R&M connection modules. The installation instructions enclosed with the connection module must always be followed.

Correct wiring / Extra twist on the outer 2 pairs /
No crossings

Incorrect wiring / Air gaps between the pairs /
Overlapping pairs / No complete entering of pairs (orange)



Correct wiring

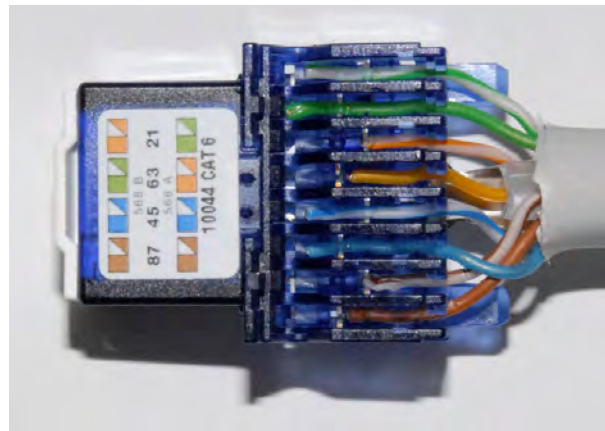

Incorrect wiring

The conductor pairs should be led directly into the module from the cable jacket, without crossing over another pair. Faultless measuring for the acceptance test can only be ensured through correct wiring. The cable jacket should be fixed on the module. The cable tie should not exert any pressure, which causes deformation of the cable jacket.

Installation

- Lay installation cables carefully following instructions from the installer or planner
- Lay the cables and try to avoid pulling them where possible (max. tensile force acc. To cable supplier)
- Use very little tension or pressure with the cable fastener
- Observe bending radii
- Avoid kinking or pinching

Test equipment

- Yearly calibration
- Daily referencing
- Use adapter cables according to manufacturer guidelines and standards to avoid possible measurement deterioration
- Always handle the Cat. 6A test adapter patch cables with care, maintain a maximum bending radius when storing
- As the test adapters have a limited usability, the test equipment manufacturers must be consulted as to the how many tests can be completed with the specific adapters.
- Frequently inspect and compare test result consistency

4. Installation

4.3 Fiber

4.3.1 Safety

Laser precaution

Laser beam used in optical communications is invisible and can seriously damage the eyes. Viewing it directly does not cause any pain and the iris of the eye does not close automatically as it does while viewing bright light. This can cause serious damage to the eye's retina, if eye is accidentally exposed to LASER beam, immediately seek medical assistance.





NEVER LOOK INTO A FIBER HAVING A LASER COUPLED TO IT!



030.7110

Laser Classification Overview

There are seven laser classifications, based on risk levels as specified in IEC 60825-1 Ed. 3.0: 2013. The classes are 1, 1M, 2, 2M, 3R, 3B & 4. Laser manufacturers are required to label their lasers with warnings and in specific cases, indicating laser emission values, laser apertures, skin hazards and invisible wavelengths also in accordance with the same standard. In addition, class 2 lasers or above, must be identified with the label as shown here.

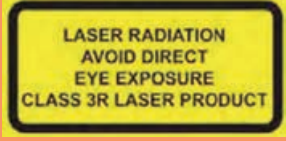
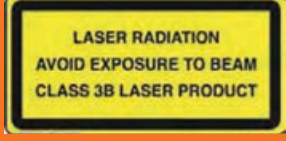
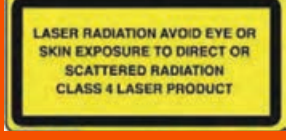
Laser Categories	Installation
Class 1 	A Class 1 laser is safe under all conditions of normal use, including when using optical viewing instruments. Class 1 also includes high powered lasers which are fully enclosed so that no radiation is accessible during use (embedded laser product)
Class 1M 	Class 1M lasers are also safe including long-term direct viewing with the naked eye. Eye injury may occur if certain viewing instruments are used under particular circumstances as described in IEC 60825-1 Ed. 3.0: 2013. The wavelength region for these lasers is 302.5nm to 4000nm
Class 2 	Class 2 lasers emit visible radiation in the wavelength range from 400nm to 700nm. Extended deliberate staring into the beam can be hazardous, but viewing with optical instruments presents no further risks
Class 2M 	Class 2M lasers emit visible laser beams like class 2 lasers and short term naked eye exposure is safe. Viewing (even temporarily) with optical instruments under certain conditions can be hazardous. However, dazzle, flash-blindness and afterimages can occur which can have indirect general safety implications
Class 3R 	Class 3R lasers have increased risk to Class 2M with a shorter time of exposure before damage can be done. Also dazzle, flash-blindness and afterimages have an increased likelihood to occur which can have indirect general safety implications
Class 3B 	Class 3B lasers are normally hazardous with direct viewing even for the shortest time. Exposure to skin may cause injuries and even pose a risk of igniting flammable materials
Class 4 	Class 4 lasers are the most dangerous and present serious risk to the eye both when directly and indirectly viewed. Even reflected beams can be dangerous. These lasers are hazardous to the skin and also present a fire risk

Laser class overview according to IEC 60825 Ed. 3.0:2013

4. Installation

Optical fiber handling precaution

The applicable standards referring to the safety issues when working with fibers and lasers are the ANSI Z136.2 or the IEC 60825-2.

The broken ends of fibers created during termination and splicing can be dangerous. The ends are extremely sharp and can easily penetrate the skin. They invariably break off and are very hard to find and remove. Sometimes a pair of tweezers and a magnifying glass are needed to take them out. Any delay in taking the fiber out of one's body could lead to infection. Hence:

- Be careful while handling fibers
- Do not stick the broken ends of fiber into your fingers
- Do not drop fiber pieces on the floor where they will stick in carpets or shoes and be carried elsewhere-like home
- Dispose of all scraps properly
- Do not eat or drink near the installation area

Material safety

Fiber optic splicing and termination processes require various chemical cleaners and adhesives. The safety instructions defined for these substances should also be followed. If there is confusion in usage of these products, ask the manufacturer for a MSDS (Material Safety Data Sheet). Remember the following instructions while working with material.

- Always work in well-ventilated areas.
- Avoid skin contact to materials involved as much as possible.
- Avoid using chemicals that cause allergic reactions.
- Even simple isopropyl alcohol, used as a cleaner, is flammable and should be handled carefully.

Primary treatments if exposed to Isopropanol & Hexane in cleaning fibers

Type of Exposure	Hexane		Iso-Propanol	
	Effect of exposure	Emergency Treatment	Effect of exposure	Emergency Treatment
Inhalation	Irritation of respiratory tract, cough	Maintain respiration, bed rest	Irritation of upper respiratory tract	Move victim into a fresh aired area, administer artificial respiration if breathing is regular
Ingestion	Nausea, Vomiting, headache	Do not induce vomiting, immediately seek, medical advice	Drunkenness & vomiting	Have a victim drink water and milk, seek medical aid.
Contact with skin	Irritation	Wipe off affected area of skin & wash with soap & water	Harmless to skin	Wipe off affected area of skin & wash with soap & water
Contact with eyes	Irritation	Wash eyes with plenty of water for 15 min	Irritation	Wash eyes with plenty of water for 15 min.

Primary treatments Isopropanol & Hexane

Safety when working with splicing machines

Fusion splicing uses an electric spark, so ensure that there are no flammable gases in the space where fusion splicing is done.

- Splicing should be avoided in places like manholes, where gases can accumulate.
- It is important to have a temperature-controlled and spotlessly clean working area to ensure good splicing.
- Smoking should not be allowed around fiber optic work. The ashes from smoking can contribute to the dust problems in fibers, apart from the danger of explosion posed by them due to presence of combustible substances

Manhole / Underground vaults safety:

- Explosive gases or vapors might be present in manholes due to leaking of nearby gas or liquid pipelines. Before entering any manhole test the manhole atmosphere with an approved test kit for flammable and poisonous gases.
- Avoid usage of any device that produces spark or flame in manhole.

4. Installation

Working safety

To minimize the risks of an accident in the work area follow specified rules for setting up barricades, man-hole guards and warning signs.

- Before pulling cable directly from figure 8 shape, make sure that the area inside the loop of the cable is clear of personnel and equipment. Failure to do so may result in injury to personnel or damage to the cable due to entanglement.
- Ensure that the tools and equipment used for cable installation are in proper condition. Corrosion of equipment may damage cable or cause injury to personnel. Take care of electric hazards, if electrical lines are passing through the manholes or vaults where installation is being done.



Cabinet aisle protection

4.3.2 Cable installation

All optical fiber cables are sensitive to damage during handling & installation. Here are some of the important parameters that need special attention during cable installation.

Unprofessional laying, for example across the edges of wall ducts, narrow cable tracks, and cable twisting while pulling it, must be avoided. Critical locations therefore need to be treated with utmost care. We recommend random sample testing of admissible bending radii in generic cabling systems after installation.

All cables that are exposed to water during installation must be replaced. Fiber cables should be cut back by 1.5m after installation, as this removes the section that has borne the majority of the tensile stress. Allow 6m of slack after installation for handling terminations and / or splicing.

Cable tensile strength

Refer to cable manufacturer's datasheet.

Tensile Strength (N)	Breakout I-V(ZN)HH	Mini-Breakout I-V(ZN)BH	Central Loose Tube I/A-DQ(ZN)BH	Stranded Loose Tube I/A-DQ(ZN)BH
Dynamic	1500	2400 – 3500 – 4500	1000	5000
Static	500	800 – 1150 – 1500	5000	3500

FO cable tensile strength

Use mechanical fuses or equivalent protection when you lay-in optical fiber cables, to ensure that the maximum tensile load established by the cable manufacturer is not exceeded. To prevent the ingress of water and other contaminants during installation, the optical cable must always remain sealed.

Exceeding cable pulling forces can cause stress on the fiber, which can increase the attenuation and might be irreversible.

Indoor and outdoor cables shall be used as specified.

It could happen that cables need to be (re)wound to another drum. The new drum needs to be as good as new, i.e. no damage to the drum that could damage the cable during the rewind. The radius of new reel needs to conform to the minimum bending radius of the cable. Also the maximum tensile strength has to be obeyed while re-reeling the cable. The original cable data needs to be copied to the new reel. Exceeding the specified tensile forces, particularly in connection with too small bending radii (main result of the high forces), can negatively alter the cable properties.

4. Installation

Cable bending radius

When fiber bending radii are too tight during installation and also in cable duct and outlet boxes micro cracks can occur.

It results in higher attenuation and will decrease the lifetime of the fiber drastically. The bending radius needs to be constantly checked when laying an installation cable.

In the event of distinctive shortfall of the laid down radii, stress applied to the installation cable or of damage through third-parties, acceptance should be refused and cable replacement is required. Wrong installation procedures, i.e.: kinking, bending radii, cable stress, torsion resulting in cable damage, will be considered the installer's responsibility. Optical fiber cables are designed with particular bending radius & tensile strength. The cable should never be bent below minimum bending radius at any location. Doing so can result in bending losses and/or breaks in the cable. Generally the bending radius of a cable is greater than $20 \times D$, where D is the diameter of cable.

Bending Radius (mm)	Breakout I-V(ZN)HH	Mini-Breakout I-V(ZN)BH	Central Loose Tube I/A-DQ(ZN)BH	Stranded Loose Tube I/A-DQ(ZN)BH
With load	$\geq 100 - 150 - 175$	$\geq 75 - 100 - 100$	≥ 100	$\geq 150 - 180 - 220$
Without load	$\geq 150 - 250 - 280$	$\geq 130 - 150 - 150$	≥ 60	$\geq 150 - 180 - 220$

FO cable bending radius

Cable Management

Optical fiber cables in vertical risers should have 2 loops installed every 10m to avoid tensile stress due to gravity induced fiber sagging. The diameter of the loop should respect the minimum bending radius.

OF cables have to be installed with a bit more care, especially when they are entering the cabinets. Also care has to be taken that the cables have enough tensile relief at the patch panels (Velcro) and when they enter the cabinet.

Preferably we would like to have a different cable route for the copper and fiber. Therefore, we recommend that fiber cables are routed and connected once all of the copper is finished.

When possible (mainly DC) use cable ducting especially designed for fiber.

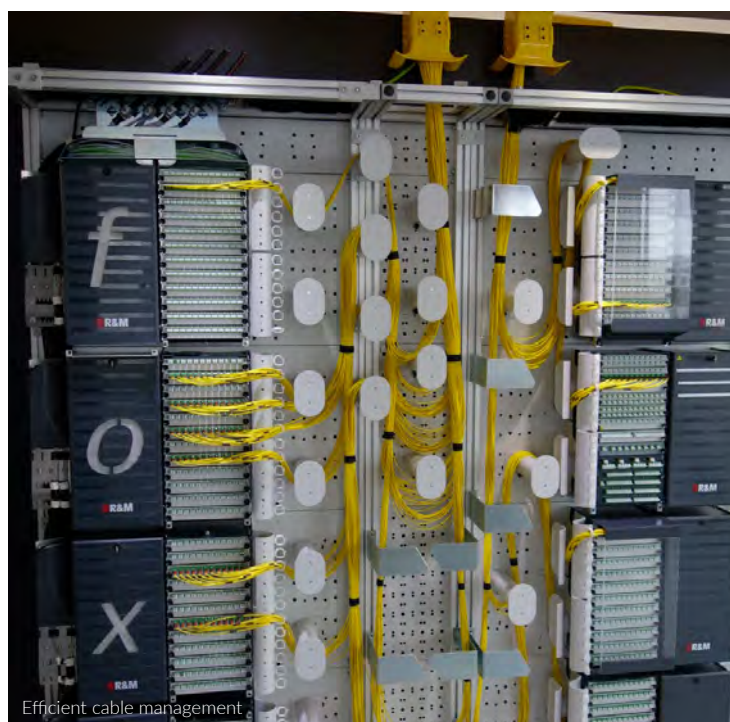

4.3.3 Cable preparation

Fiber optic cables should only be terminated with suitable tools. If, for example, a knife or an unsuitable stripping tool is used when stripping the cables, there is a risk of damaging the inner workings of the cable. If this is the case, it is very likely that fiber breaks, bruising or other sources of error will be caused. It is also important to use the tear threads (if any) when stripping the outer sheathing. If there are two tearing threads, both should also be used.

If the cable has filling material or rodent protection, it should be cut back to where the outer sheath was removed. Depending on the application, it is recommended to remove up to 4m of the cable sheath. There are also customers who prescribe a special length for the storage of loose tubes. The stripped cable should be fixed well and the loose tubes, if they are twisted, should be treated with a hot air dryer so that they run straight and no longer have a twist. The loose tubes themselves should be prepared with a suitable tool. There are punch pliers with various diameters or tools that scratch the loose tubes to break them clean by hand.

Afterwards the fibers must be cleaned until no gel residues are left. There are various special cleaning agents for this, if necessary isopropyl alcohol can also be used without any problems. There are also gel-free loose tube cables, so-called dry loose tube cables. At the point where the loose tube is inserted into a splice cassette, a suitable adhesive tape (fiberglass tape or fabric tape) must be inserted around the loose tube, as the loose tube is likely to slip away on the cable ties alone.

Commercial insulating tape is not recommended, as this can become detached when the splice cassette is hot and therefore no longer securely held in place. The coating of the fiber should be removed with a special stripper (miller pliers), then the bare fiber must be cleaned with a lint-free cloth and isopropyl alcohol before further preparation.



Tools for preparation and termination of fiber cables

4. Installation

4.3.4 Fiber cable termination

Termination of connectors

There are several ways of terminating fiber optic cables, such as but not limited to:

- Field termination
- Break-out cable termination
- Fusion splice
- Mechanical splice

Marking and color coding of fiber adapters and connectors

Correct coding, for example by color of connectors and adapters, is important. It ensures that mating of different fibers does not occur. For duplex links use additional keying devices to ensure the right polarity.

To distinguish between single-mode and multimode adapters and connectors use only the following colors:

- Multimode 50um and 62,5um Beige, Black, Aqua, Magenta or Lime Green
- Singlemode PC Blue
- Singlemode APC Green

Termination FO Field

The FO Field is a field-attachable connector which is available as LC and SC as well as multimode and all singlemode variants. Thanks to its easy handling and good performance, it is a very useful plug for repairs, smaller service orders, special applications and special productions where it is not possible to splice. A fiber cleaver is the only specialist tool required to terminate this type of connector.



030.6320
LC APC connector FO Field

The FO Field assembly process is simple:



Step 1 - 021.2716

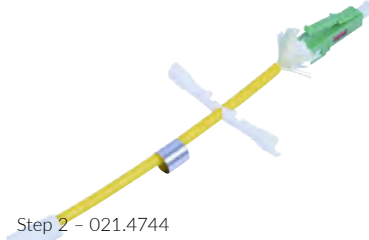

Step 2 - 021.4744



Step 3 - 021.4749

Cable preparation and cleaving

Break fiber to length

Insert cable into rear of connector

Insert fiber into connector until it stops, lock fiber in place by pressing window and clamp

Ensure tensile strength

Attach strain relief to connector

Assembled FO Field connector



Installation Manual
FO Field

4. Installation

4.3.5 Patch cables

It is recommended to use bend insensitive fiber patch cables in the patching environment as they have become an important key factor in reaching the target channel performance.

Patch cables should be replaced after 1000 matings.

When doing MACs with patch cables the utmost care has to be taken not to apply excessive stress to the patch cord involved as well to the patch cords in the direct environment. The maximum tensile force on the patch cords should not be exceeded, please consult the relevant data sheet for the values.

It is highly recommended to use R&M patch cords with any installed R&M System.

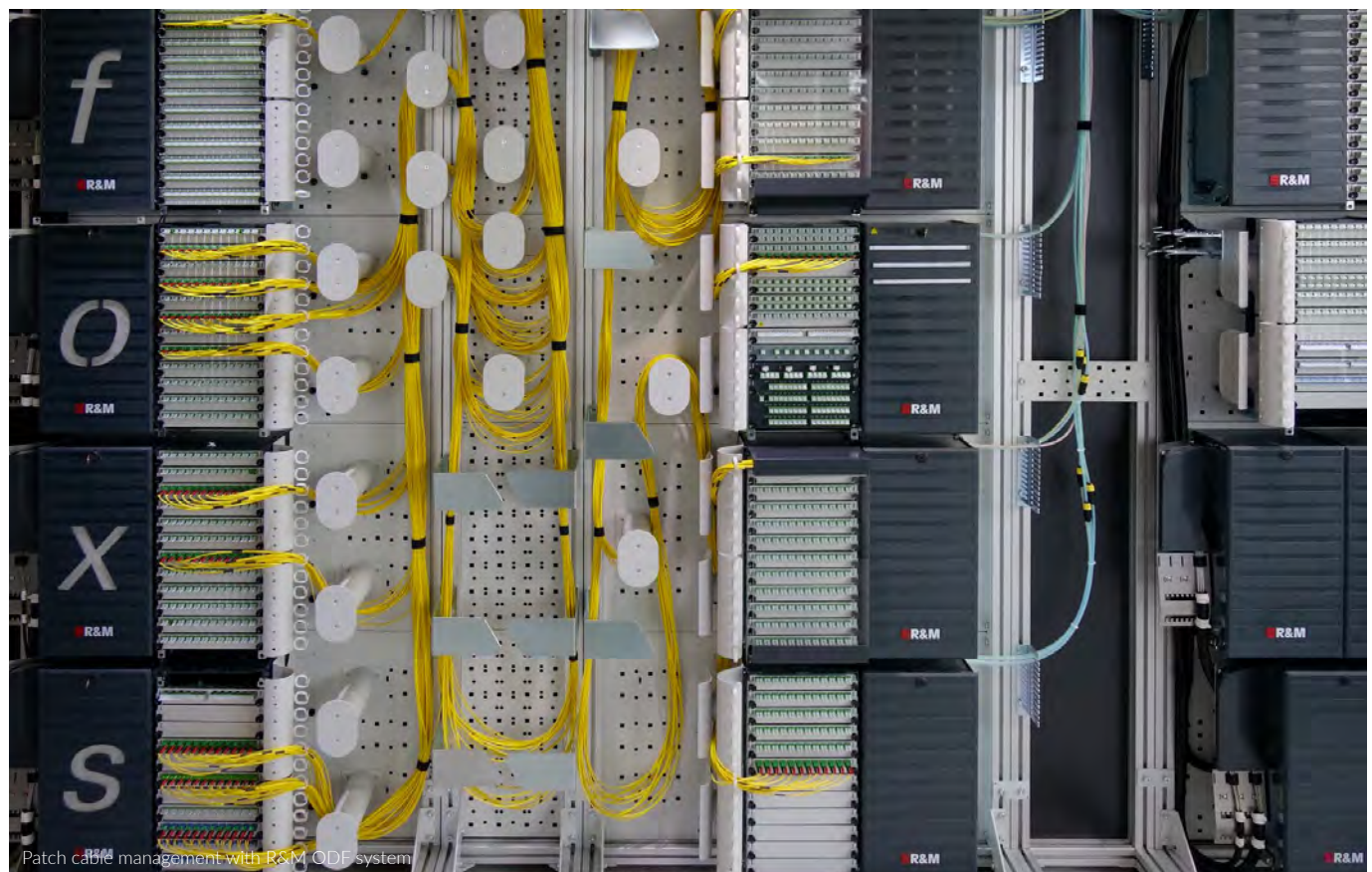

4.4 Installation checklist

The following lists the characteristics of a proper and professional installation:

- Adequate personnel must be present at site to pull the installation cables.
- Before routing the cables, edges of openings and pipes must be rounded off, to avoid damaging the jacket when the cables are later routed and fastened.
- Cable ducts or conduits must be used when passing through walls. Remember that the standard requires these spaces to be only 50% occupied, i.e. it is foreseen that the same amount of cables will be added during the lifetime of the current cables.
- When installing the cable, the bending radius may not be less than that specified by the cable manufacturer. The same applies after the cable has been installed.
- To avoid accidental cable damage, the cables should be laid directly from the cable reels along the cable routes and should not be laid out for several meters along the floor.
- Ensure that adequate tools for cable unrolling, lay down and/or pulling as well as pulleys for corners are available and personnel instructed on their usage.
- Any sign of stress or kinks in the cable sheath insulation or conductors must be avoided (e.g. caused by improper fastening or by the weight of crossed installation cables).
- The radius of the channel route must be selected so that the specified minimum bending radius is maintained when changing direction.
- Metallic ducts or raceways must be properly connected and bonded to ground.
- Do not bundle cables (especially U/UTP) together. If this is not possible/ practical then limit the number of cables bundled together.
- Cables tie guns or similar tools may not be used when fastening various types of cables, nor may they be used when fastening cable ties to provide connection module strain relief.
- No pressure may be exerted on the cables because of improper tying from using quick cable installers or cable ties. The basic principle is that the geometry of the cable jacket must not change.
- Cable channels must be closed after work has been completed (raised floors, wall ducts, etc.) to avoid dirt and damage which could influence the transmission properties of the installed cables.
- Data cables are sensitive to direct sources of heat: hot air blowers or gas burners used for installing shrink tubing must not be used in the vicinity of data cables.
- If chemicals are used to facilitate cable pulling, be sure they are compatible with the cable sheath material.
- This is also applicable to any chemical (mostly spray type) used for other types of cables that may accidentally get in contact with data cables.

5. Post-installation

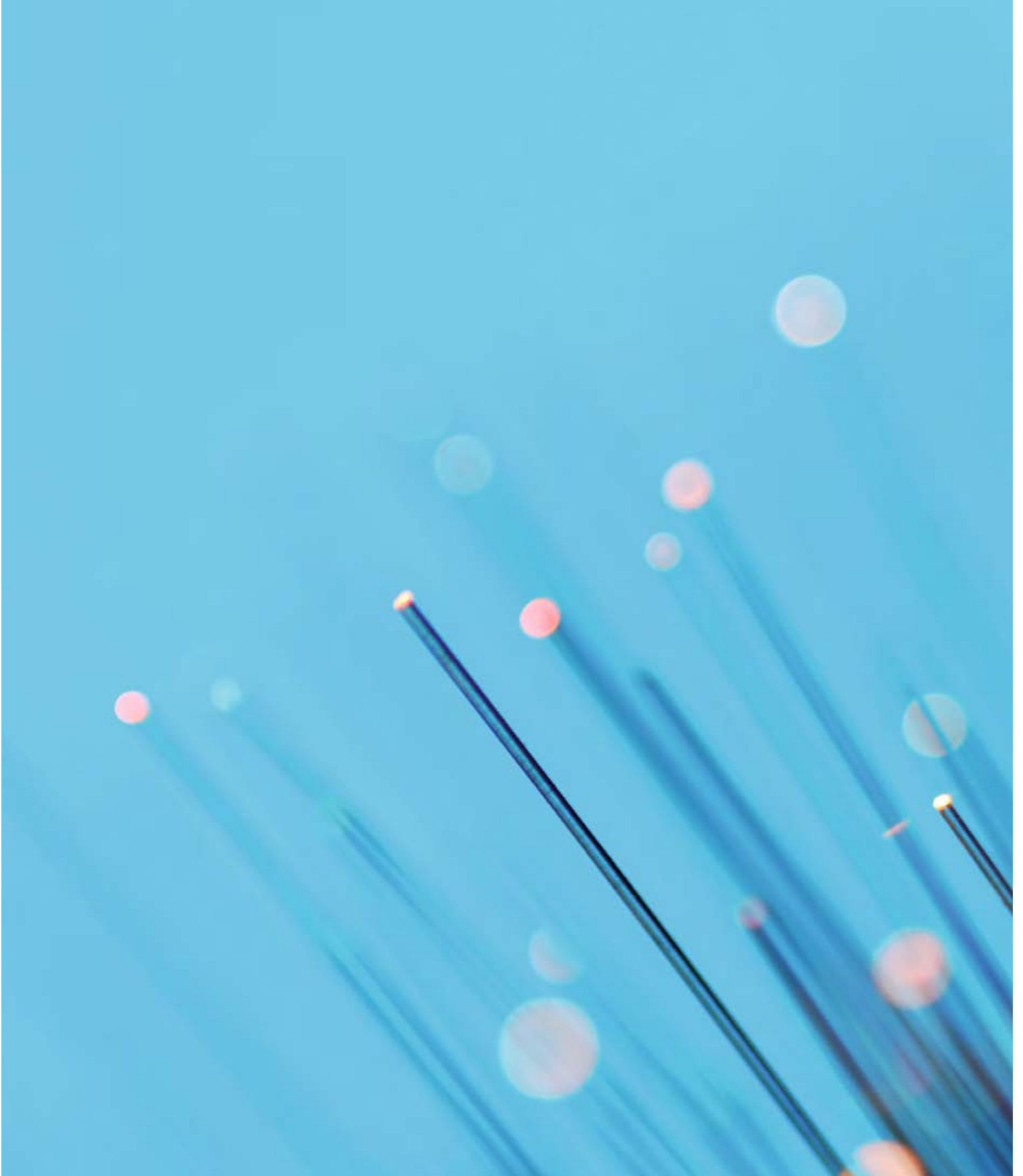

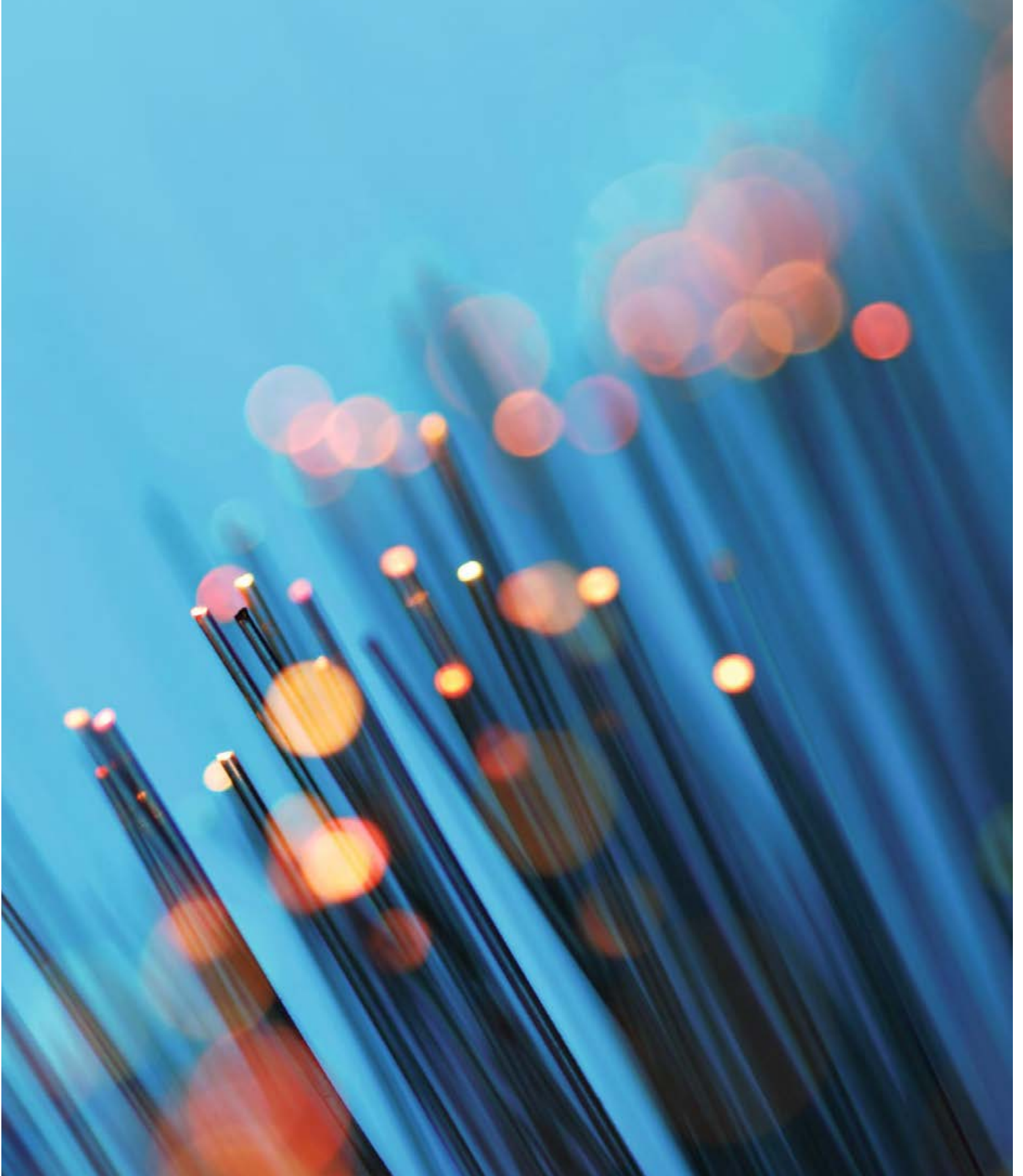

5. Post-installation

5.1 General

5.1.1 Measurement accuracy

WHEN A «PASS» IS A «PASS» AND WHEN A «FAIL» IS A «FAIL»?

When testing cabling installations in the field, questions always arise regarding test equipment readings and analysis of the measurements. The customer, usually the installer, naturally wants to see only «pass» and an asterisk or warning is viewed with suspicion. What exactly are the facts?

Standards EN 50173 and ISO/IEC 11801 contain only the values to be expected for the cabling. The «how to test» aspect is not covered or is covered only in a rudimentary fashion. Standard IEC 61935-1 is used for this purpose: «Specification for the testing of balanced and coaxial information technology – Part 1: Installed balanced cabling as specified in the standards series EN50173». This standard describes the precision of the test equipment and the reporting of the data, among other items.

Any test equipment has a certain precision; i.e. the displayed measurement can be incorrect by +/- a certain amount. This is shown in the following diagram:

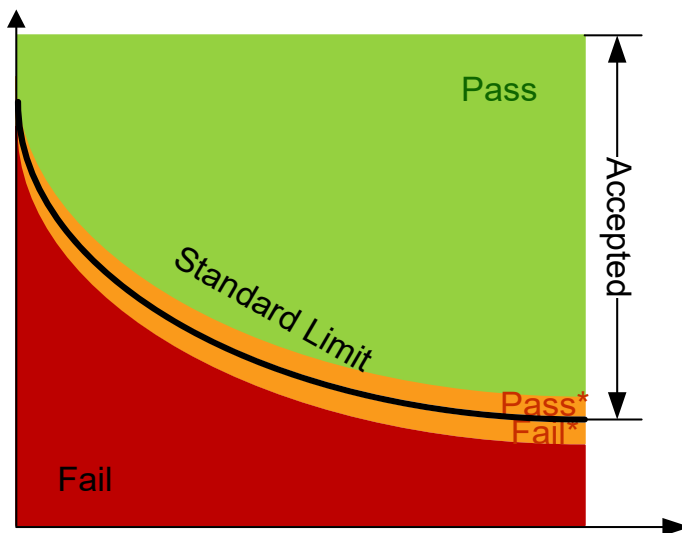

Test equipment measurement tolerance

The test result of a parameter shall be marked with an asterisk (*) when the result is closer to the test limit than the measurement accuracy.

An overall pass or fail condition shall be determined by the results of the required individual tests. Any FAIL or FAIL* shall result in an overall FAIL, unless specified otherwise in a quality assurance agreement. In order to achieve an overall pass condition, all individual results shall be PASS or PASS*.

«*FAIL» OR FAIL IS AN OVERALL FAIL – «*PASS» OR PASS IS AN OVERALL PASS

It is highly recommended to test to the Permanent Link (PL) in the allowable standards, as this is a sterner test and enables flexibility of the changes to the patch cords of the system without the need to re-test. If channel tests are undertaken, the standards identify the need to maintain the connection of the patch cords into the system once the test has been conducted.

This means that when conducting tests for the channel, a single set of patch cords cannot be used to stay with the tester and conduct all of the tests. The channel test means that all of the patch cords for the entire system at both ends must be in place and used as part of the test. If a patch cord is replaced, the link must be re-tested. R&M only allows R&Mfreenet products within our warranty system and therefore when testing to the channel, only R&M patch cords must be used.

Warranty application requires a valid calibration certification (pdf) for test equipment used (typically once per year) and for fiber links also the cable plans to be submitted.

5. Post-installation

5.2 Copper

5.2.1 Approved certification test equipment for class D/E/E_A / Class I

Warranty application requires valid calibration certification for test equipment (typically once per year). Testers that show the latest calibration date in the test reports do not require separate calibration certificate submission.

The listed test equipment is approved for executing certification measurements and producing an original measurement file, which is needed to apply for a warranty (see «Appendix 1 to the warranty program» chapter 4.2).

Class D	Cat. 5e	MHz 1 - 100	Class E	Cat. 6	MHz 1 - 250	Class E _A	Cat. 6 _A	MHz 1 - 500	
AEM TestPro CV100			AEM TestPro CV100			AEM TestPro CV100			
Fluke DSX-600/5000/8000 VersivTM			Fluke DSX-600/5000/8000 VersivTM			Fluke DSX-600/5000/8000 VersivTM			
Ideal LanTEK II, LanTEK III, LanTEK IV (≥V1.34)			Ideal LanTEK II, LanTEK III, LanTEK IV (≥V1.34)			Ideal LanTEK II, LanTEK III, LanTEK IV (≥V1.34)			
Softing WireXpert WX4500 WireXpert WX500			Softing WireXpert WX4500 WireXpert WX500			Softing WireXpert WX4500 WireXpert WX500			
VIAVI Certifier 10G, Certifier 40G			VIAVI Certifier 10G, Certifier 40G			VIAVI Certifier 10G, Certifier 40G			

Test equipment accepted for warranty applications

Approved certification test equipment for Class 1 systems can be found online at www.rdm.com

Notes

- Class E_A and Cat. 6A do not specify the same performance
- This is the status at time of release of the document.
The current valid status of the list can be found on the R&M website: www.rdm.com
- Test equipment must be regularly referenced
- All pre-terminated cables must be tested after installation, especially for warranty application





5.2.2 Appropriate test adapter for class D/E/E_A/Class I

In principle, any one of the following standards may be selected to test according installation:

Permanent Link (PL) Class D / Cat. 5e	Permanent Link (PL) Class E / Cat. 6	Permanent Link (PL) Class E _A / Cat. 6A	Permanent Link (PL) Class I / Cat. 8.1
ISO 11801-1 PL Class D	ISO 11801-1 PL Class E	ISO 11801-1 PL 2 Class E _A	ISO 11801-1 PL Class I
EN 50173 PL Class D	EN 50173 PL Class E	ISO 11801-1 PL 3 Class E _A	EN 50173 PL Class I
TIA Cat. 5e PL	TIA Cat. 6 PL	EN 50173 PL 2 Class E _A	TIA Cat. 8.1 PL
		EN 50173 PL 3 Class E _A	
		TIA Cat. 6A PL	
Channel Link Class D / Cat. 5e	Channel Link Class E / Cat. 6	Channel Link Class E _A / Cat. 6A	Channel Link Class I / Cat. 8.1
ISO 11801-1 Channel Class D	ISO 11801-1 Channel Class E	ISO 11801-1 Channel Class E _A	ISO 11801-1 Channel Class I
EN 50173 Channel Class D	EN 50173 Channel Class E	EN 50173 Channel Class E _A	EN 50173 Channel Class I
TIA Cat. 5e Channel	TIA Cat. 6 Channel	TIA Cat. 6A Channel	TIA Cat. 8.1 Channel

Test equipment standard selection

5. Post-installation

Module	Cable	PL & CH Class E / Cat. 6 (ISO/EN/TIA)	PL & CH Class E _A / Cat. 6A (ISO/EN/TIA)	PL & CH Class I / Cat. 8.1 (ISO/EN/TIA)
Cat. 6 		OK	-	-
Cat. 6 _A EL 	Minimum cables approved for 500 MHz and more	OK	OK	-
Cat. 6 _A ISO 		OK	OK*	-
Cat. 8.1 	Cables approved for 2000 MHz	OK	OK	OK

*Best in Class

Test equipment adapter selection

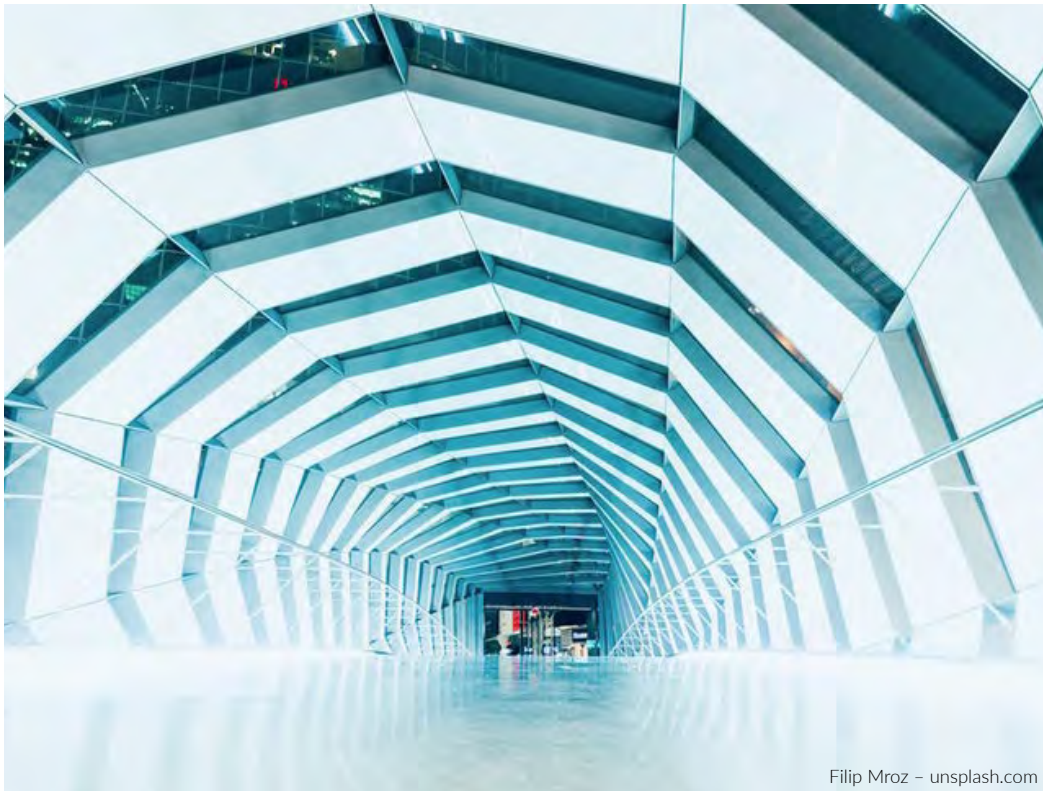

Filip Mroz - unsplash.com

5.2.3 Test link configurations

The warranty program provides for the following three test setups for copper cabling.

Permanent Link

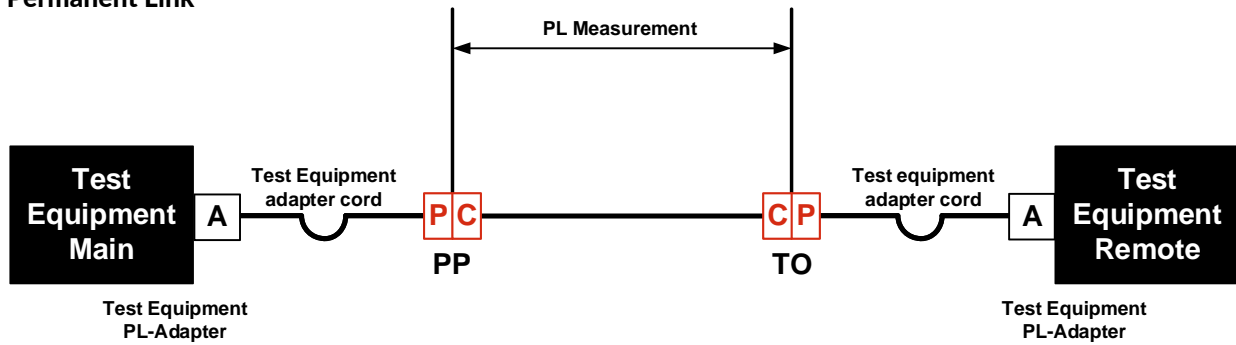

Sample test link PL

Channel

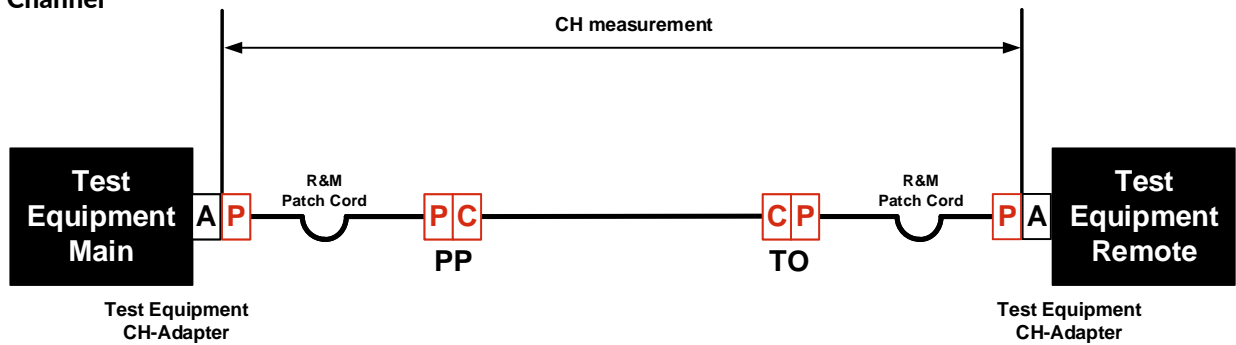

Sample test link CH

MPTL (Modular Plug Terminated Link)

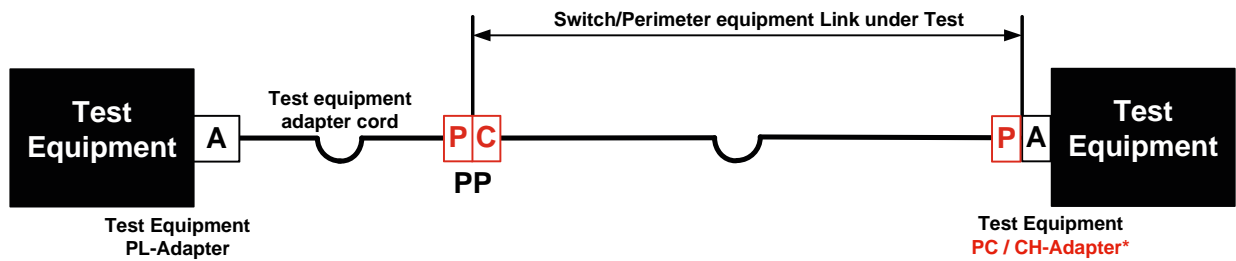

*CHECK MANUFACTURER INSTRUCTIONS

Sample test link MPTL

5. Post-installation

Permanent Link with Consolidation Point

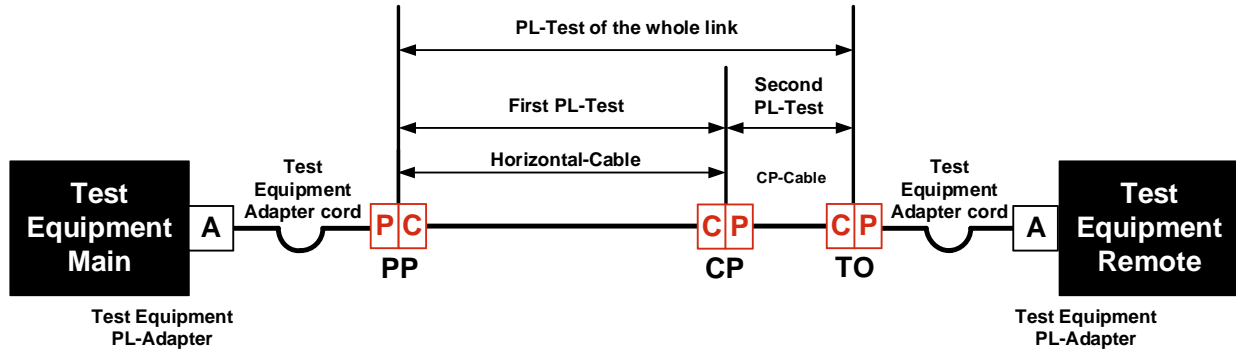

Sample test link PL with CP Method 1

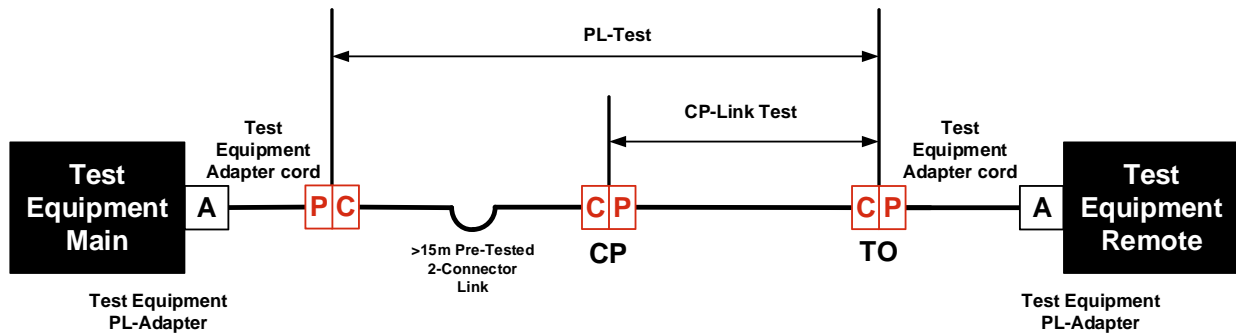

Sample test link PL with CP Method 2

5.2.4 Measurement Analysis

In the image below you have many of the important parameters listed.

A failure in the wire map indicates mostly one of the pairs is incorrectly connected or there is a problem with the screen.

Return Loss failures are often an indication that the parameters of the cable have changed either the bending radius and/or tensile strength were not respected or the cable was subjected to humidity. Analysis of the trace below shows increased disturbance of the cable, indicative of pulling the cable to hard under tight bending.

Summary		FAIL
E-1.38		
ISO11801 PL2 Class Ea		
X	Wire Map	
✓	Resistance	
i	Length	53.8 m
✓	Prop. Delay	
✓	Delay Skew	
✓	Insertion Loss	(20.3 dB)
✓	Return Loss	(3.4 dB)
✓	NEXT	(9.0 dB)

Highlight item, Press ENTER

Fault Info Page Up Page Down

Summary		FAIL
E-1.38		
ISO11801 PL2 Class Ea		
✓	Wire Map	
✓	Resistance	
i	Length	103.4 m
✓	Prop. Delay	
✓	Delay Skew	
X	Insertion Loss	(-4.1 dB)
✓	Return Loss	(3.5 dB)
✓	NEXT	(9.0 dB)

Highlight item, Press ENTER

Fault Info Page Up Page Down

HDTDR Analyzer

Value: 6.1

Zoom

Set Mark Change To Cursor Plot by Pair

HDTDX Analyzer

Value: 3.8

Zoom

Set Mark Change To Cursor Plot by Pair

A failure in Insertion Loss often goes together with lengths that are beyond the standard's maximum link allocation.

If the NEXT fails it often is due to a bad termination of connectors. The example below shows clearly that the connector on the right has been badly terminated.

Measurement Evaluation Analysis

5. Post-installation

Detailed Step description

Step 1

A low battery level can have a negative influence on the test results. This influence varies from test equipment to test equipment. It is therefore best practice to avoid low battery levels on your test equipment. Have the routine of charging the TE whenever there is a long break in testing or at the end of the day.

Step 2

Certain TEs allow pre-programming of the test limits per project, making sure there is no confusion when using the same TE for different projects. If this is not the case, make sure the correct standard and link configuration is chosen. Keep in mind ISO and EN the channels are «CLASS» measurements and the TIA is in «CAT», but all components have a «CAT» classification.

Step 3

Select the type of cable that will be tested, i.e. unshielded (U/UTP) or shielded (U/FTP, F/UTP, F/FTP, S/FTP), if you are not sure check the cable sheath. Unless otherwise required, it is easier to select the generic type of cable and then manually adjust the cable's NVP (step 5). With shielded cable it is desired to test the shielding continuity.

Step 4

Choose the cable's category; this is marked on the cable sheath.

Step 5

Set the NVP value, which is also marked on the cable sheath. This parameter is important to make sure the correct electrical cable length is shown and to troubleshoot the correct location when there are problems with the link.

Step 6

To ensure maximum accuracy of copper cable test results, perform this reference procedure every 30 days. Most customers set the reference daily.

Step 7

Make sure that the correct adapter is in use for the link under test, i.e. do not use Cat. 6 adapters to test Class E_A links. Certain manufacturers have dedicated PL and CH adapters, so they should not be mixed or used for the wrong link test.

Step 8

Measure the Link under test, while doing this make sure the nomenclature and labeling all conforms to the requirements and standards. Check if there are no apparent defects or broken parts.

Step 9

Analyze the test results and check if they are conformant to the projects requirements are the known component performances. E.g. links with the R&M *freenet* Cat. 6_A module should have a NEXT value of above 4dB, lesser values reflect issues with the connectivity. Very low RL values could be an indication there are issues with the cable. If there are problems with a link, write them down and report them to the team leader so further corrective actions can be taken.

Step 10

Save the good test results with the correct nomenclature under the appropriate folder.

Step 11

Create the project documentation for the customer including the organized test results

5.3 Fiber

5.3.1 Approved certification test equipment for fiber

R&M accept all forms of test equipment suitable for measuring optical fibers, both the LSPM (Light Source Power Meter) and the OTDR (Optical Time Domain Reflectometer), all makes and models are acceptable. A tester must be able to store test results to enable these results to be organized and transferred electronically in the event of warranty application.

R&M recommends the use of an LSPM for results measuring, as this provides more accurate figures and is generally quicker to test.

All of the test equipment used for testing needs to be calibrated according the TE manufacturer's documented procedures. The calibration frequency is in general yearly. The proof of calibration needs to be included when applying for a warranty.

All measurements in the field must be carried out with reference measuring cables.

The measuring instruments must be able to store the test results in electronic form. The original results can then be managed more easily and must be transmitted electronically in the case of a warranty request. Manually written tables or PDF's are not accepted!

For OTDR measurements, the measurements must be processed with an analysis program (Fibercable, Fastreporter, Fiberdoc, Linkware etc.) and documented cleanly. The events must be set, the launch fiber, tail fiber, plug connections and distance must be clearly visible. If loop measurements are made, the events of the «Link-Loop-Link» transition must also be set. The value table / event table must contain the link events and comply with the limit values of the required standard.

Setting the events is so important because with good APC connections it is sometimes not visible where the link starts, ends or has connections. It is then no longer possible to determine where the transitions of launch fiber, tail fiber or loop back link are. It is therefore important for the measurement technician to know the exact length of his test results so that a clean evaluation can be carried out later.

OTDR measurements that are not processed and properly documented, which make it impossible to trace the installed routes, will not be accepted and rejected for warranty request.

5. Post-installation

Direct MPO measurements with LSPM

Since this cabling method is relatively new and is not yet described in the standards, we would like to comment on this topic with our recommendations and specifications. In general, we recommend testing MPO links with fanouts if conventional testing is required.

If MPO is to be measured directly, i.e. the conventional measuring methods are not applicable, the MPO measuring instruments used must be able to test and identify the following parameters:

- Length (must be measured by the device)
- Attenuation & budget
- 2 Wavelengths (MMF 850/1300 nm & SMF 1310/1550 nm)

Not many of these MPO testers are yet available on the market. The functional principle is the same as for LSPM measurement (see [chapter 5.3.5](#)). There are differences in the limit values as these have not yet been defined in the standard. Since only a few IEEE applications are possible for MPO direct cabling up to now, their limits should be paid attention.

In practice, the maximum permissible length of the link and the maximum total attenuation are then defined as limit values. The meter then measures the effective values (length and attenuation) and indicates the attenuation reserve.

Direct MPO measurements with OTDR

Certain precautions must be taken when measuring MPO cabling directly with an OTDR. At this time there are no OTDR measuring devices with MPO connection and MPO launch and tail reference leads. The following measurement variants are currently possible.

- Use fanouts or MPO cassettes on both sides and perform a conventional or loop measurement
- Use an OTDR MPO switch (manufacturers of OTDR devices offer such MPO switches)

In OTDR measurement of MPO direct cabling, the MPO connection is divided into individual fibers by the fanout or the MPO switch. A normal OTDR measurement is then performed (see [chapter 5.3.6](#)). For fanouts or MPO cartridges, the connector transitions (LC from fanout and MPO) are displayed as an event due to the meter's dead zone. If the events are to be displayed separately (i.e. as two individual events), the fanouts must be long enough and the pulse width of the tester adapted.

The MPO switch is connected between the OTDR and the feed and controls the individual fibers of the MPO trunk. On the other hand, a fanout or MPO cassette must be used so that the trailing fiber can be inserted. If MPO launch and tail cords are available, they can be used and the use of the fanout or the cassette is not necessary.

For MPO connections it is particularly important that the connector surfaces are inspected and 100% clean before insertion. MPO is extremely susceptible to contamination as it affects several fibers at the same time. In addition, the loss/attenuation budgets are very strict and allow for little tolerance.

5.3.2 Test link configurations

The warranty program provides for the following three test setups for fiber cabling.

General requirements and channel attenuation according to the current version of the standards.

Permanent Link

The permanent link measurement allows the measurement of the installed FO cabling, exclusive of the equipment cords. This test method is comparable with the PL testing configuration for copper cabling. The level of acceptable test system certainty and to incorporate the random mating fluctuation is defined at its reference planes. In the permanent link configuration the test cord connectors are included in the measurements. Following figure shows some examples of links and which connections are included in the test.

Reference cords must be used for all measurements

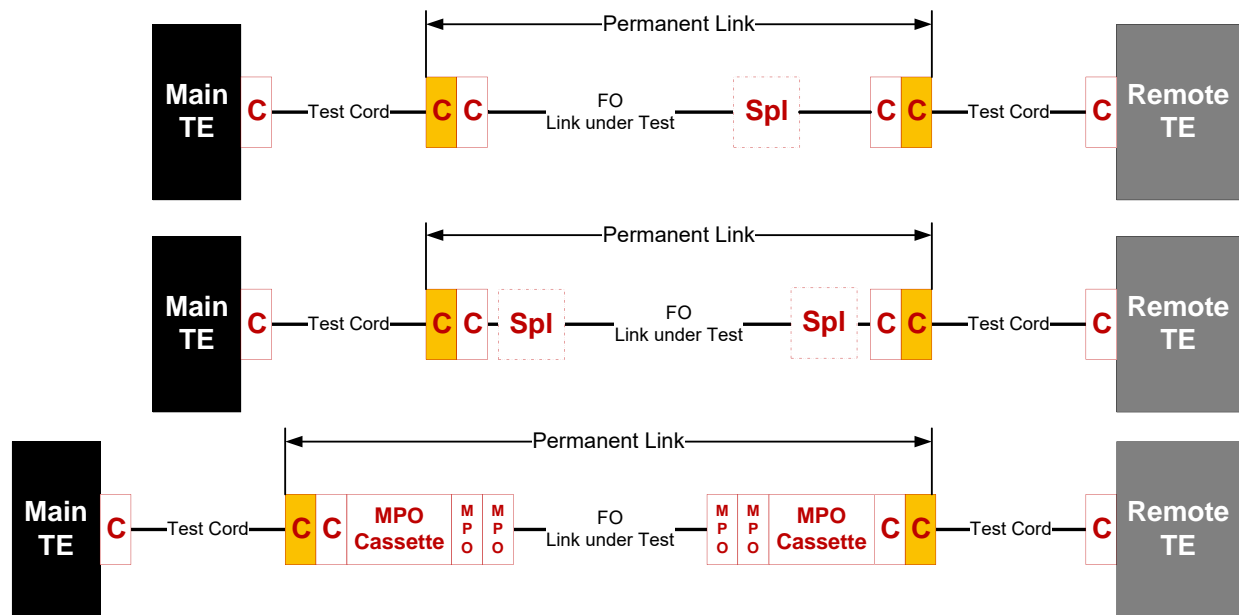

FO Cabling Permanent Link Configuration

C	Reference connector
C	Connector
Spl	Splice
TE	Test Equipment
MPO	Multifiber Push On

5. Post-installation

Channel

The channel measurement includes the testing of the equipment cords attached to the installed FO cabling. This means after a channel acceptance test the equipment cords need to stay in place. Here the reference planes include the equipment cords, but exclude the connectors attached to the test cords, as they will be attached to the equipment. Following figure shows the same examples as with the PL but measured in Channel.

Reference cords must be used for all measurements

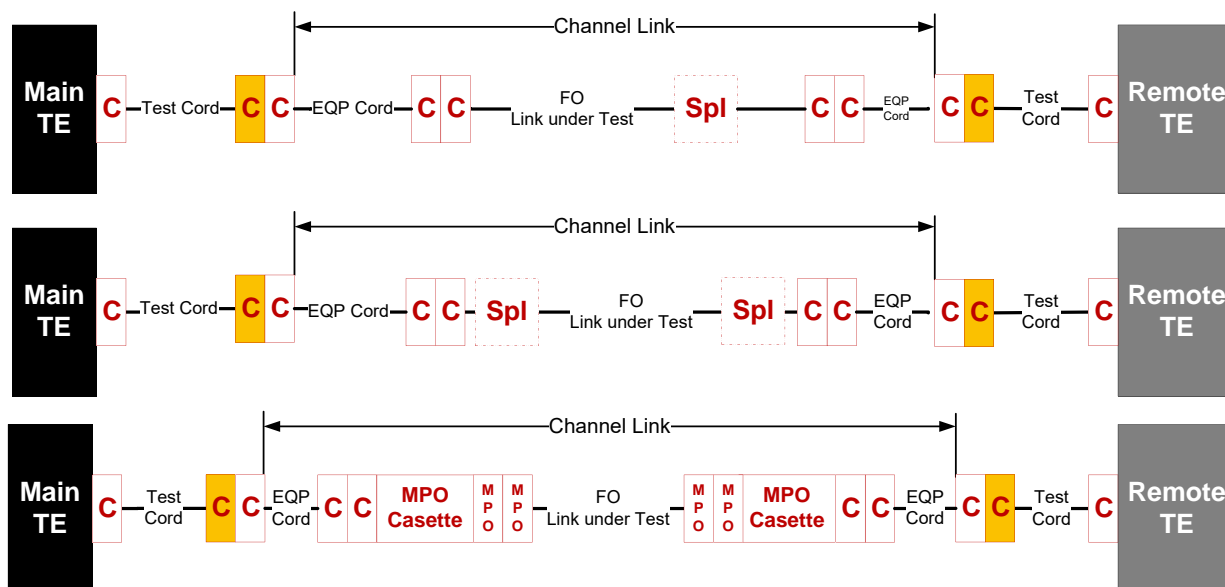

FO Channel test configuration

POLAN (Splitters)

When testing a POLAN-System, we recommend to test it in two parts. As it is not possible to test through a splitter, in both directions. To get a warranty for these kinds of system the links should be split. Do a test of the link in front and another test of the link after the splitter.

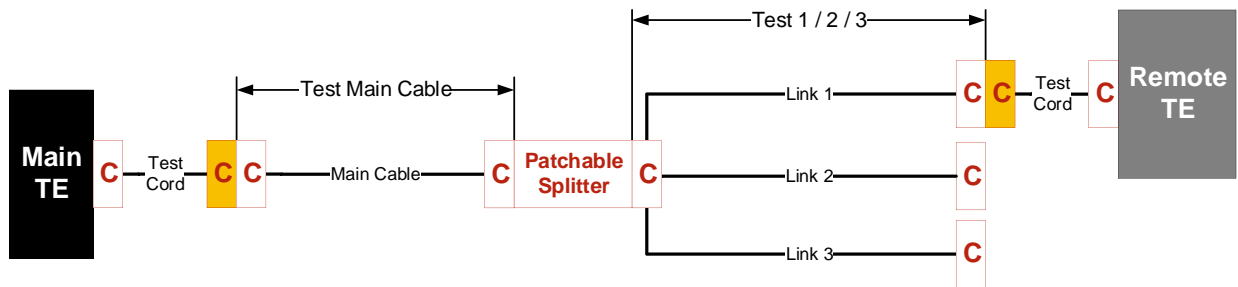

Direct test not possible through splitter

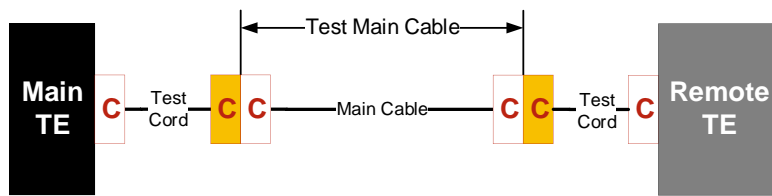

Split installation in two parts and test main cable

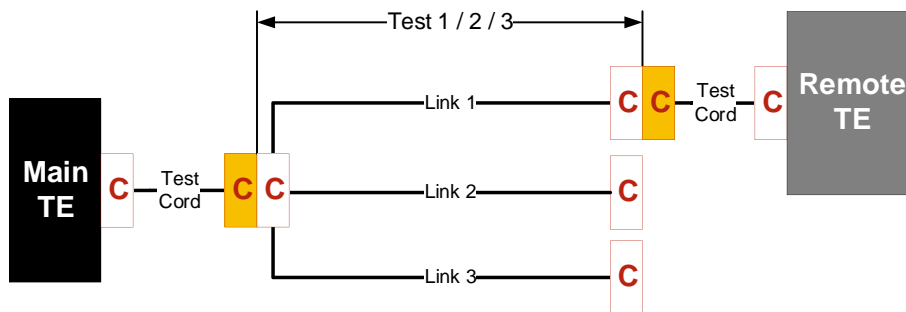

And each outlet individually

5. Post-installation

5.3.3 Inspection and cleaning

ICC

INSPECT, CLEAN (if necessary) then CONNECT

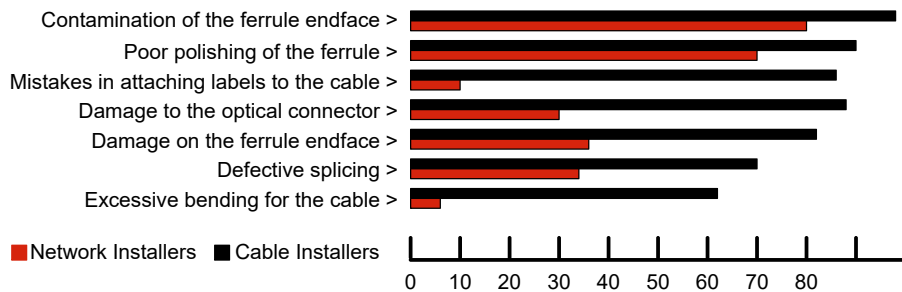

Most Common Faults in Fiber Optic Installations

The performance and reliability of an optical fiber system depends strongly on the cleanliness of the connection components. Small impurities like dirt, dust, etc. can possibly destroy a fiber optic connector. Therefore the following procedure is strongly recommended: Visual inspection of the surface (with microscope). Clean the surface following the instruction of the manufacturer. After cleaning inspect again the surface, if clean than make the connection.

What do the standards say

The ISO 14763-3 and TIA 568-D both refer to the ISO 61300-3-35 as part of the testing procedure. All the endfaces involved in the test setup should have been inspected according to and with equipment specified in the ISO 61300-3-35.

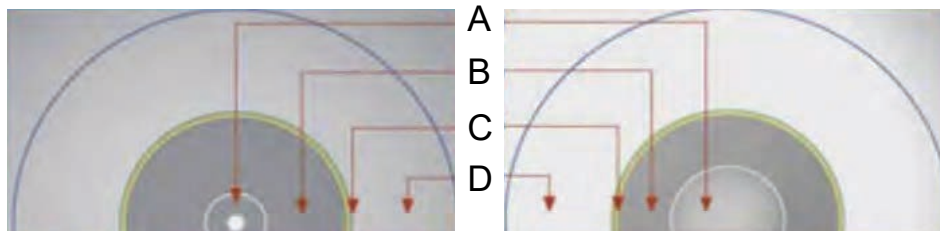

ISO 61300-3-35 SMF & MMF

Singlemode				Multimode		
Defects	Scratches	Zone		Zone	Scratches	Defects
None	None	Core (0-25µm)	A	Core (0-65µm)	None	4≤5µm None>5 µm
No limit <2µm 5 from 2-5µm None >5 µm	No limit ≤3µm None >3µm	Cladding (25-120µm)	B	Cladding (65-120µm)	No limit ≤3µm None >5µm	No limit <2µm 5 von 2-5µm None >5 µm
No limit	No limit	Adhesive (120-130µm)	C	Adhesive (120-130µm)	No limit	No limit
None ≥10 µm	No limit	Contact (130-250µm)	D	Contact (130-250µm)	No limit	None ≥10 µm

ISO 61300-3-35 criteria

Examples of good and two badly cleaned fiber optic connector surfaces (dust/dirt, grease/oil/finger prints)



Examples of cleaned fiber optic connector surfaces

If the endface of the connectors do not qualify according the above mentioned criteria, they should be cleaned and inspected until they do. Once both endfaces of a connection qualify according the ISO 61300-3-35 then they can be mated. Integrating this procedure into the testing process also avoids possible future arguments on who is to blame if a link is faulty due to contaminated or even broken connector endfaces.

When contaminants adhere to the core, they will cause increase in signal interruption and increase amount of insertion loss and degradation of return loss. Also, these kinds of contaminants can cause chips, pits, and scratches in the connector end face under the pressure of the physical connection. Large contaminants can result in gaps in the physical connection, resulting in increased loss. These kinds of contaminants can actually spread and migrate by the physical connection.

5. Post-installation

Examples of cleaning materials that must be used:

- Active microscope
- Lint-free rods
- Lint-free wipes
- Isopropyl alcohol, when using IPA to clean an end face, you need to apply a dry clean wide afterwards to avoid a residual film of the IPA on the endface.
- Dry cleaning tape
- IBC cleaner
- Cletop cleaner

A useful practice is to inform and instruct the end customers IT manager about best practices when working with fiber links and the need for cleaning the endfaces of the connector with each manipulation.



Fiber endface cleaning equipment



Fiber endface inspection tool

5.3.4 FO test conditions

In order to get reliable and repeatable measurements of FO cabling and its component it is important to use a good test system, adapters and reference connectors.

Inspect, Clean and Connect (ICC)

Any contamination of the end faces, be it those of the link under test or those of the test cords, will provide misleading results. Furthermore, there is a potential risk that the connectors may get irreparably damaged during the testing process.

The connector end faces of the test cords shall be inspected and cleaned if necessary according to [chapter 5.3.3](#), this means not only the connectors under test but also the reference connectors of the test cords.

If a connector is damaged it shall be replaced. For test cords this either means the cord needs to be completely replaced or returned to the manufacturer to be fitted with a new reference connector.

Launch conditions

The launch modal distribution conditions for LSPM and OTDR should reflect the optical characteristics for which the FO cabling is installed. If the test equipment does not provide this, then the cords should be adapted with a suitable mode controlling device.

For LSPM measurements this means that the light source used will be LED for MMF testing and Fabry Perot lasers for SMF testing. VCSEL light sources are excluded.

The measurement wavelength characteristics shall be according the IEC 61280-1-3, it could be that for SMF 2 coils or mandrel wraps of 35 mm to 50 mm are needed. Please check with the TE supplier.

Encircled Flux

This test will replicate light conditions which comes as close as possible to the «real modal environment» of a VCSEL transceiver. The VCSEL signal is used by future applications supporting 10G, 40G and 100G on MMF.

When using these test conditions the light source and mode control within the test cords will result in an output at the end of the launch test cord that conforms to the IEC 62614 and 61280-4-1.

Reference measurement cables

The measuring standard ISO 14763-3 stipulates that reference measuring cables must be used for measuring installations. These special cables are equipped with reference plugs on the end that is connected to the installation to be measured. Reference connectors have special properties and much smaller manufacturing tolerances. The fiber is perfectly centered in the ferrule of the connector for greater accuracy and repeatability when measuring fiber optic installations. If one would use normal (random) connectors with higher tolerances for measurement, one would have the problem that larger deviations occur. It is possible that with two connected plugs the cores are perfectly aligned and you get a very good measurement result. In the next case, the cores may be further apart due to the higher tolerances, which would result in a very poor result. For this reason, reference measurement cables must be used when measuring fiber optic installations.

5. Post-installation

Test cords and adapters

The components of test cords and the adapters used shall have the same or better performance specifications than those used in the link under test. The connectors on the test cords that will connect to the cabling under test will be reference connectors according to the specifications in ISO 14763-3. The following table shows the allowed maximum attenuation of 2 reference connectors mated against each other in a reference adapter.

Connector Type	Cylindrical connector style		Rectangular connector style	
	MMF	SMF	MMF	SMF
Mode				
Attenuation (dB)	≤ 0.10	≤ 0.20	≤ 0.10	≤ 0.20
Return Loss (dB)	≥ 35	≥ 45 (PC), ≥ 60 (APC)	≥ 35	≥ 45(PC), ≥ 60 (APC)

Reference-Reference mating loss budget

The test cords for LSPM measurements shall be no shorter than 2m, but not too long that the attenuation of the cords has a significant influence on the measurement. We recommend lengths between 2 m and 3 m.

According to ISO 14763-3, the test cables (launch, tail, loop) for OTDR measurements should not be shorter than 75m for MMF and 150m for SMF in order to reproduce a clearly visible measurement trace before and after the link to be measured. In other words, a nice clean line should be observed before the first and after the last connection to be tested.

How do I treat the power loss measured with reference connectors?

The link attenuation (Optical Power Loss) must be calculated for each FO cable. The attenuation power loss budget for the measurement is different as random connectors will be mated with reference connectors.

Connecting Attenuation	MMF		SMF	
	Random Mated	Against reference connector mated	Random Mated	Against reference connector mated
Grade Am&Bm	IL Mean ≤0.15 dB IL >95% ≤0.25 dB	≤ 0,30 dB		
Grade M	IL Mean ≤0.35 dB IL >95% ≤0.50 dB	≤ 0,50 dB		
Grade A&B			IL Mean ≤0.12 dB IL >97% ≤0.25 dB	≤ 0,50 dB
Grade C&D			IL Mean ≤0.25 dB IL >97% ≤0.50 dB	≤ 0,75 dB
Generic	IL 100% ≤0.75 dB		IL 100% ≤0.75 dB	

Reference/random mating loss budget

For links measured in channel there is no difference to the budget calculations according the ISO 11801, EN 50173 and TIA 568 if using R&Mfreenet connector grades.

For links measured as a permanent link the values in Table «R&Mfreenet connection attenuation» on page 169 «against reference connector» should be used. for the connections at the extreme end of the cabling under test.

Power Loss Limit can be calculated with the following formula:

$$\sum (2 \times \text{«against reference connector ATT»}) + \sum (\text{cable ATT}) + \sum (\text{embedded connection ATT})$$

Sample calculations

Assuming a 100m MMF link has two pigtails grade Bm connections, the measured power loss limit would be calculated in the following way.

Permanent Link:

$$\text{at 850 nm} = (2 \times 0,5) + (0,1 \times 3,5) + (2 \times 0,3) = 1,95 \text{ dB}$$

$$\text{at 1300 nm} = (2 \times 0,5) + (0,1 \times 1,5) + (2 \times 0,3) = 1,75 \text{ dB}$$

A SMF cabling infrastructure of a single sided Grade B OS2 preterm link of 500m with a grade B pigtail will have a maximum link loss limit of:

$$\text{at 1310 nm / 1550 nm} = (2 \times 0,75) + (0,5 \times 0,4) + (1 \times 0,3) = 2.0 \text{ dB}$$

5. Post-installation

5.3.5 LSPM testing

In order to get a system warranted by R&M, the optical system should be measured according to the requirements of ISO/IEC 14763-3 and equivalent standards. There is no difference in the procedures, but the test equipment may be different. LSPM and OLTS are basically the same type of testers, they just measure the effective loss of the link. The difference is that OLTS testers often have extended options, are more «intelligent» and more user friendly, while the LSPM testers basically just measure the loss. Note that older test limits, like e.g.

The OF-Classes are no longer standards compliant and should not be used anymore.

Many testers still give the possibilities to choose these older test limits.

Direction

For compliance testing of a channel or link, bi-directional testing MUST be conducted if the line is spliced or if there are multiple connectors.

If it is a pre-assembled line (fixed line with associated connectors), without splicing, unidirectional measurement is possible, provided that the test cables have the same fiber properties as the installed link.

Best general advice: TEST BI-DIRECTIONALLY

Reference Configuration

For LSPM testing only the «one jumper» method is accepted. The 2 & 3 jumper method is no longer allowed, because they are not standards compliant anymore. Make sure that all necessary adapters are available for the LSPM to test all possible connector types. Also a set of test reference cords for all possible connector type combinations should be utilized for testing. The «extended 3-jumper» method needs the same reference process, there are minor differences while measuring which are explained on the following pages.

Wavelength

Every link **MUST** be tested at the upper and lower frequency windows, i.e. MMF @ 850 nm & 1300 nm and SMF @ 1310 nm & 1550 nm. It can be that the end customer requires additional wavelengths to be tested.

Settings

Certain LSPM test equipment will allow the setting of link parameters in order to immediately check if the measured attenuation is within a certain standard's limit. Here is an overview of some of these parameters:

- Standard Limit: determines the loss budgets limits for a link
- Fiber type: this parameter will use the fiber loss parameters
- Bi-directional: Measuring from A-B and B-A, an average of these values shows a more precise, realistic result
- Number of adapters: this is the amount of adapters present in the link under test, for a pre-term link this will be 2, for a link with MPO trunk cables and cassettes this will be 4.
- Number of Splices: the amount of splices present in the link
- Connector type: The type of connector used in the link, this parameter is informative and has no bearing on the test limit calculation.
- Test method: for LSPM the R&Mfreenet warranty program requires the «one jumper» reference method for permanent link testing.

Index of refraction	850 nm	1300 nm	1310 nm	1550 nm	1625 nm
OM3/OM4/OM5	1,482	1,477			
OS2			1,467	1,467	1,468

FO cable index of refraction

5. Post-installation

Reference

For LSPM test methods a reference needs to be set between the light source and the power meter. The following referencing methods are accepted. The illustration shows the referencing and the measuring process with unidirectional (ignore faded connections) and with bidirectional (include faded connections) measuring devices.

«one jumper» method & «Extended 3-Jumper» method

The cords used to set the reference must fulfill the standards requirements.

To measure all possible connector types, you need all adapters for you LSPM to fit the connectors.

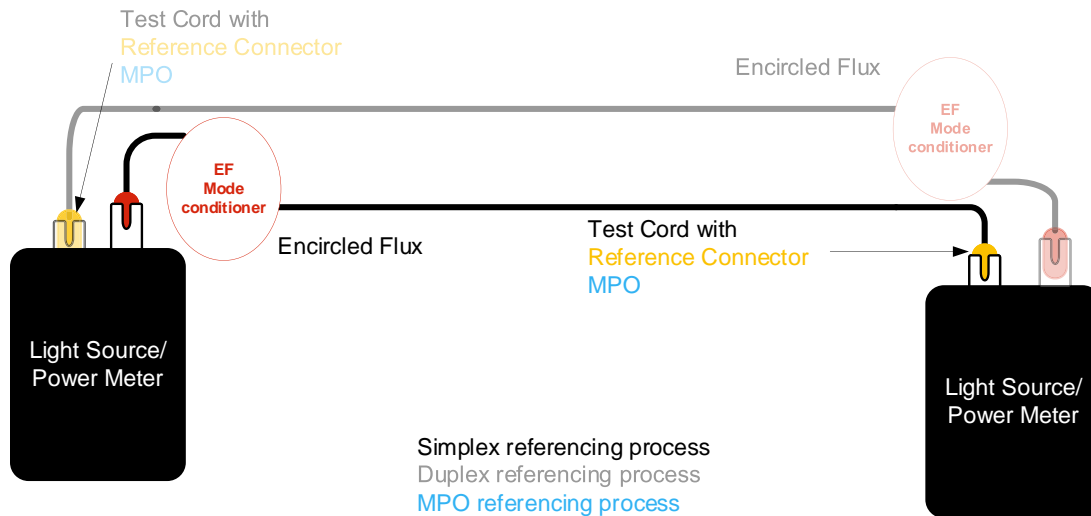

«one Jumper» reference method

Verification

After referencing the LSPM and lead calibration cord, the reference connectors on the lead and tail cords must be checked for quality. Make the following test setup and measure the link, this one needs to be **less than 0.1 dB for MMF and less than 0.2 dB for SMF**. Save the measured value and add it to the test documentation for the warranty application. Repeat this step after each reference setting or when the measurement results are deteriorating.

«One jumper» method:

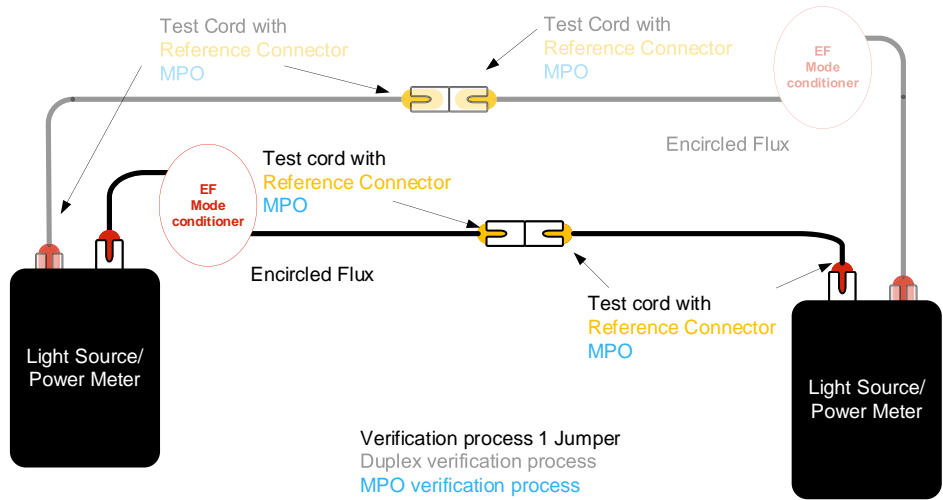

«one Jumper» method verification

«Extended 3-Jumper» method

This method is only allowed when the link has different connectors on each end. After doing the reference attach a substitution cord with matching reference connectors on each end. Check the loss on the power meter, it needs to be less than 0.2dB for MMF and less than 0.4dB for SMF.

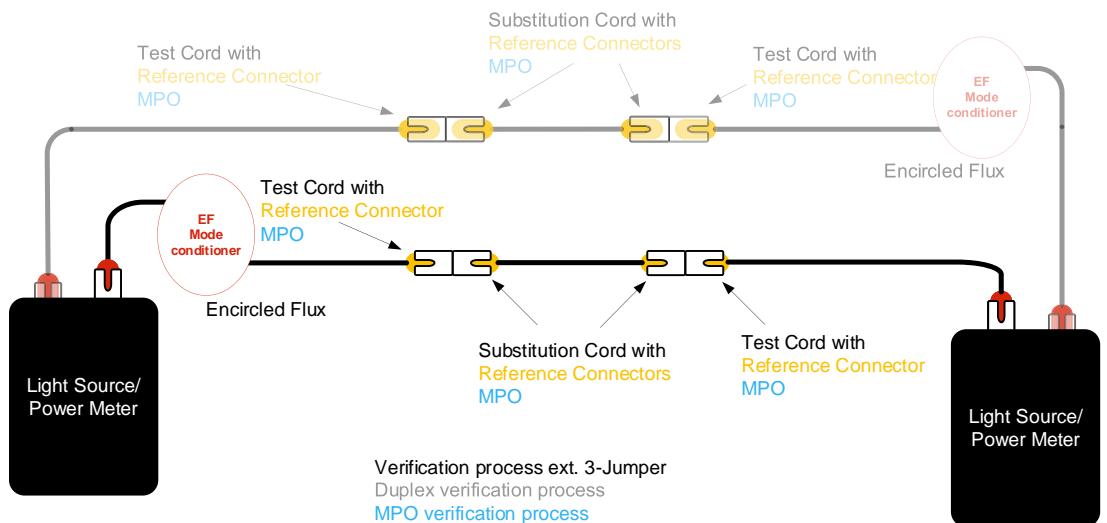

«extended 3-Jumper» method verification

Important: Don't do a new reference with the substitution cord (putting the power meter to 0dB) this step is only for verification if the connector quality is good enough.

5. Post-installation

Measuring

The «cabling under test» can now be measured by connecting the lead and tail test cord to each end of the link. When «Extended 3-Jumper» method was used for referencing and validation, remove the substitution cord and replace it with the link that should be tested.

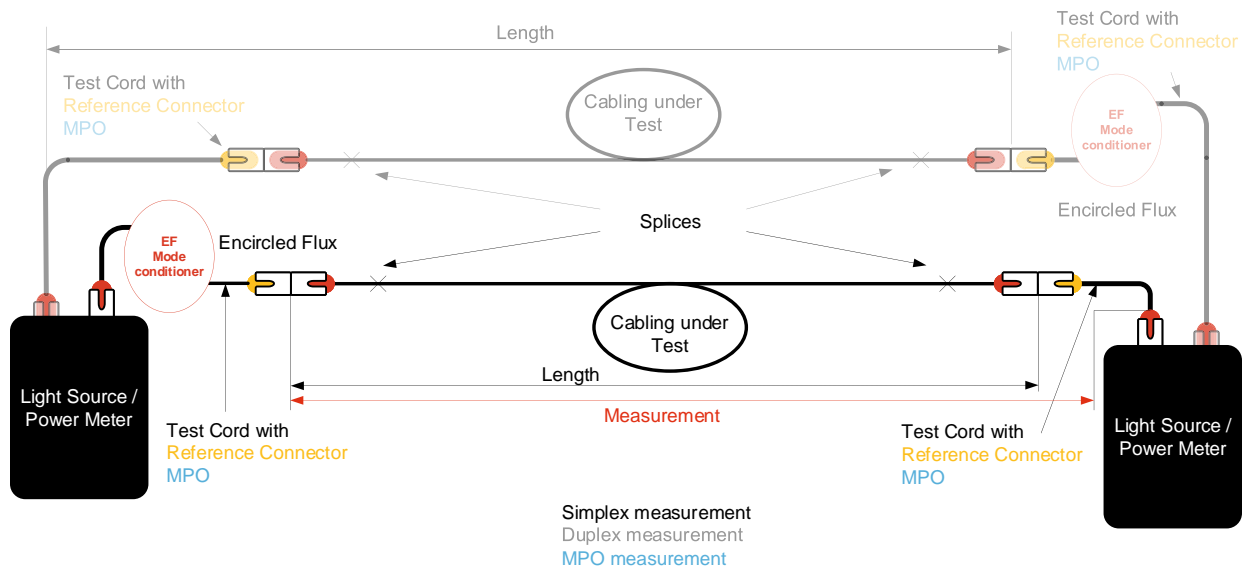

Measurement of a PL

An example for a channel measurement:

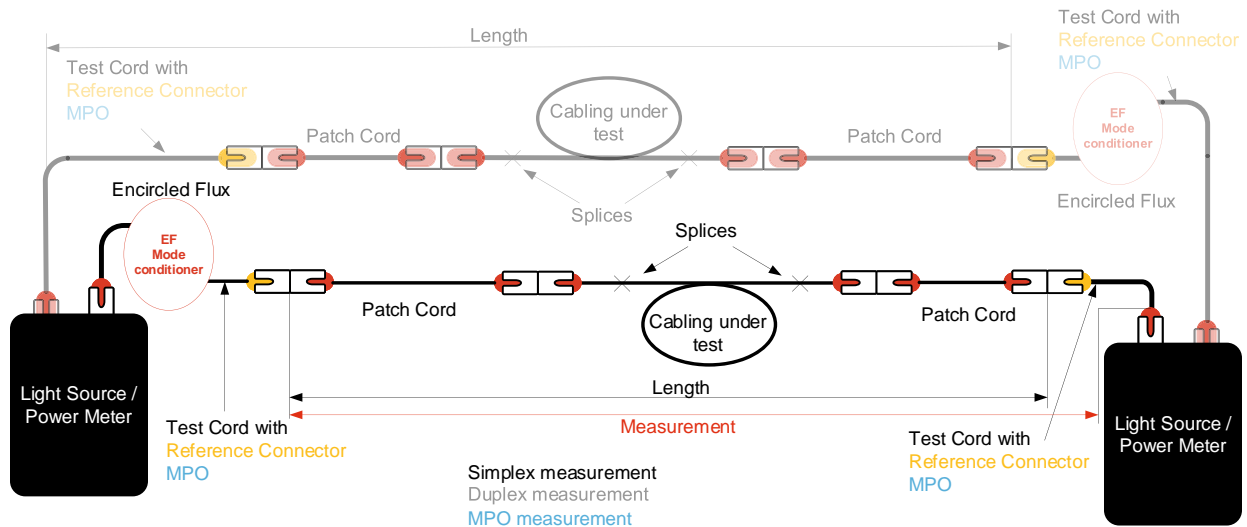

Measurement of a CH

Detailed Step description

Step 1

A low battery level can have a negative influence on the test results. This influence varies from test equipment to test equipment. It is therefore best practice to avoid low battery levels on your test equipment. Have the routine of charging the TE whenever there is a long break or at the end of the day. The LSPM test equipment needs about 15min of temperature acclimatization before the light source will have stable performance.

Step 2

Some test equipment allows the setting of parameters that will allow the TE to calculate the power budget for the link, these are the parameters set on the top, i.e. test limit, fiber type, amount adapters/splices, type of connector, index of refraction.

Step 3

Set the reference, i.e. the one jumper reference with one test cord between light source and power meter (reference connector).



Donald Chodeva – unsplash.com

Step 4/5

Remove the test cord from the power meter and add another test cord between the power meter and the first test cord for PL testing. Make sure both reference connectors are mated against each other with a SMF coupler.

This test is to verify the quality of the reference connectors on the test cords, they should be better than MMF IL ≤ 0.10 dB, SMF IL ≤ 0.20 dB, MMF/SMF PC RL $\geq 35/45$ dB, SMF APC RL ≥ 60 dB.

This step should be done regularly or when replacing any of the test cords. For channel testing remove the equipment cord from the power meter and add the other equipment cord to the power meter. No verification testing is needed for channel testing.

Step 6

ICC of the link end faces and test cord end faces. Measure the Link under test, while doing this make sure the nomenclature, direction and labeling is all conformant to the requirements and standards. Check if there are no apparent defects or broken parts.

Step 7

Analyze the test results and check if they are conformant to the projects requirements and the known component performances. For channel testing both equipment cords should be left connected to the link and the mop should be repeated from step 3.

Step 8

Save the good test results with the correct nomenclature under the appropriate folder

Step 9

Create the project documentation for the customer including the organized test results (see [chapter 5.3.7](#))

5.3.6 OTDR testing

Direction

Multimode and singlemode fiber transmission links can be tested with OTDR testers. The difference here is that every single event of the link can be measured and controlled separately.

If splices or other plug connections are present on the installed line, bi-directional measurement is mandatory according to ISO/IEC 14763-3 & IEC 61280-4-1&2. In addition, with bidirectional measurements, the launch and tail fibers must be left plugged in and only the OTDR must be shifted so that a clean averaging of the values is possible.

The launch fiber of measurement A-B thus becomes the tail fiber of measurement B-A and vice versa. The difference in core diameter can lead to optimistic results on the one hand and negative results on the other, so that it is not possible to determine the actual loss of an event in unidirectional measurements.

Unidirectional measurements are only permitted if there are no splices or other plug connections on the measured distance. In addition, the launch fiber and tail fiber must have the same properties as the installed link.

Loop measurement

Loop measurements are allowed. Be aware that the loop fiber must have reference connectors on both sides and should have the same length as launch and tail cord. This means that one duplex link can be tested simultaneously, multiple loops are not permitted for warranty applications. However, it is important to realize that loop measurements do not warrant the polarity of the installed cabling and that any verification of this needs to be done separately.

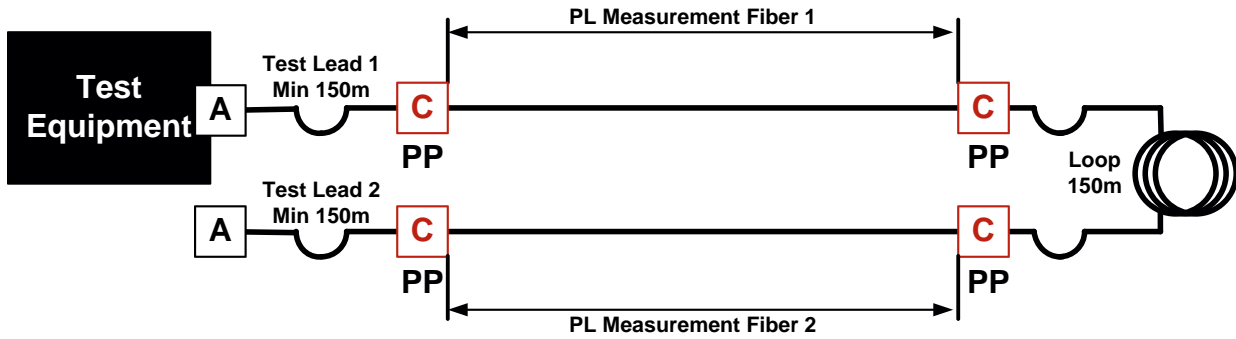

OTDR Loop measurement A to B

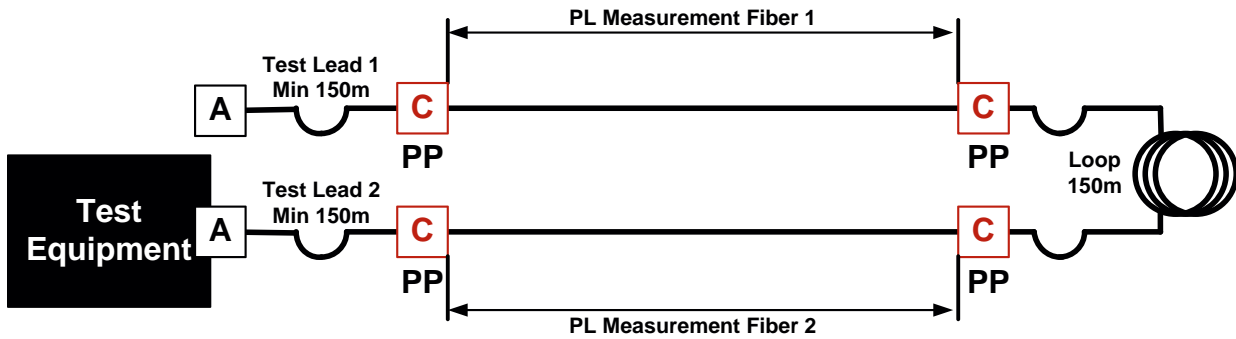

OTDR Loop measurement B to A

5. Post-installation

Settings

Range

The range shall be set in such a way it at least covers all test cords and the cabling under test, e.g. If there are 2 test cords of 500m and the longest link under test is 350m, the range will be at least 1350m.

Dynamic range

The dynamic range determines the maximum observable length of a fiber and is an OTDR specific parameter. It is an extrapolation of the backscatter trace compared to the noise level, the better the SNR the better the trace and event detection. If fibers with a high attenuation need to be tested, it is better to check with the TE manufacturer if the equipment is suited.

Wavelength

Every link **MUST** be tested at the upper and lower frequency windows, i.e. MMF @ 850nm & 1300nm and SMF @ 1310nm & 1550nm. It can be that the end customer requires additional wavelengths to be tested.

Pulse width

The pulse width gives an indication of the power sent into the fiber; the larger the pulse the more power is transmitted. A wide pulse will allow further travel along the fiber, but also means that the width of the reflections become wider. A wider reflection will also hide more of the backscatter signal, i.e. it will increase the event and attenuation dead zone.

The pulse width must be adapted to the cable length. If necessary, set the pulse width in the tester to «Automatic» and adjust the measuring range as accurately as possible to the cable length.

Averaging time

This function defines the time it takes to sample the link, the longer the time the better the SNR and characterization of the trace. The time chosen should allow good analysis of the cabling under test. This time is dependent upon the equipment but the general accepted min time is 20s. If the distances are less than 100m, 10 seconds can be set, for distances over 100m, at least 20 seconds must be set. With SMF it is generally recommended to measure at least 20 seconds

Index of refraction for R&Mfreenet FO cables

Index of refraction	850nm	1 300nm	1310nm	1550nm	1625nm
OM3/OM4/OM5	1,482	1,477			
OS2			1,467	1,467	1,468

FO cable index of refraction

Verification Test of the test cords

In order to comply with the fiber optic test conditions verification is required that the test cords which are used (launch, tail and loop) to perform the tests are within the specifications stated in [chapter 5.3.4](#). This verification needs to be done **and recorded** at the start of each test sequence. Make sure that the lengths of the test cords are known, specially for APC testing.

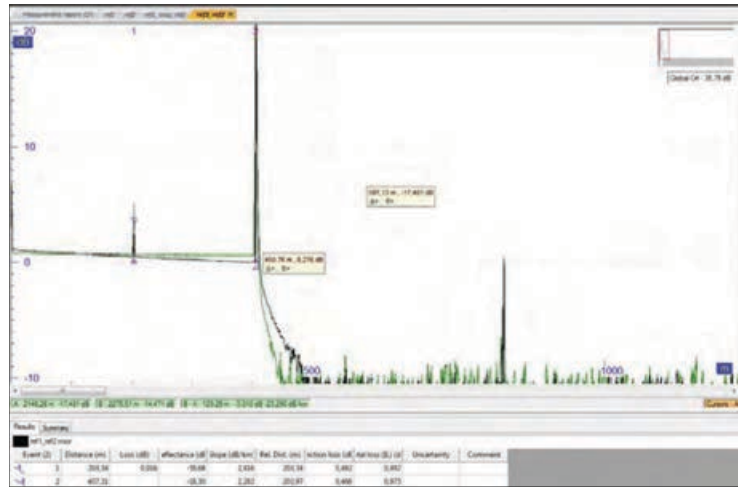

Test lead 1&2 reference connector verification

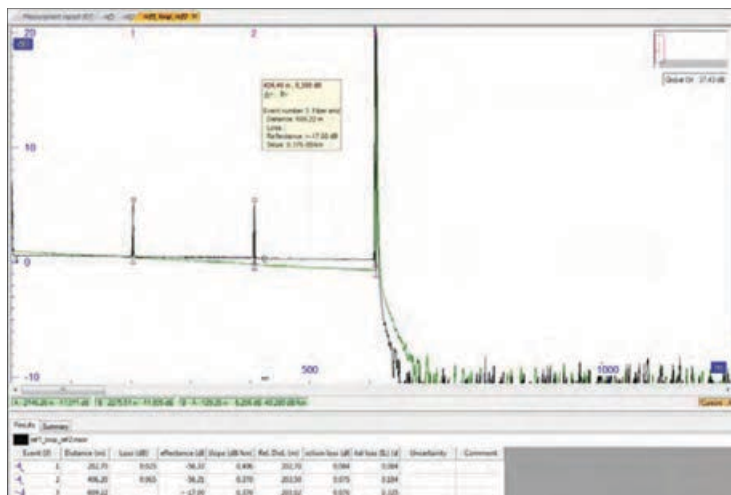

Test leads and loop reference connector verification

Make the following test setup and measure the connector losses, they need to be **less than 0.1dB for MMF and less than 0.2dB for SMF**. Save the measured value and add it to the test documentation for the warranty application. Repeat this step after each reference setting or when the measurement results are deteriorating.

5. Post-installation

When testing links with APC connectors it is very difficult to determine the start and end of the test cords and links under test. Therefore we require also the individual test trace of each test cords used in the warranty application. So the trace of the first and second test cords and the loop test cord if used, must be included in the application documentation. It is not as clearly visible as on picture 168 where the plug transitions are.

It is therefore particularly important that the measurement technician sets the events correctly when measuring with the OTDR. If there are several events (as is the case with a loop measurement,

for example) and the measuring device does not recognize all events automatically, the events must be set manually. The OTDR recognizes most events by itself, but this is not always the case with good APC connections. This simplifies the later evaluation and documentation of the measurements on the PC enormously.

In addition, we require reference measurements of each test cable used in the warranty request. Therefore, the traces of the first, second and loop test cable (where used) must be added to the documentation of the application.

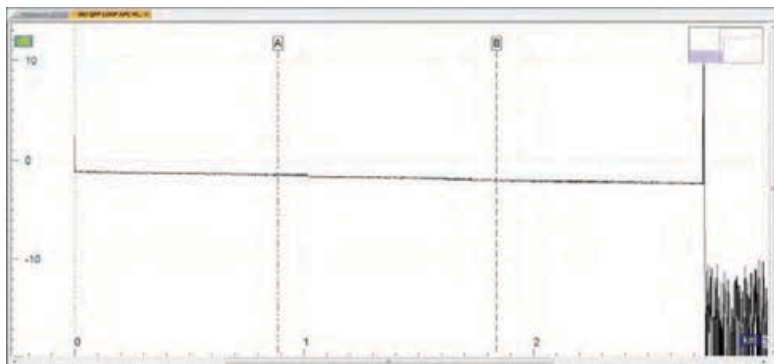

Test cables 1&2 and link 3 with APC connectors (events not set, i.e. not visible)

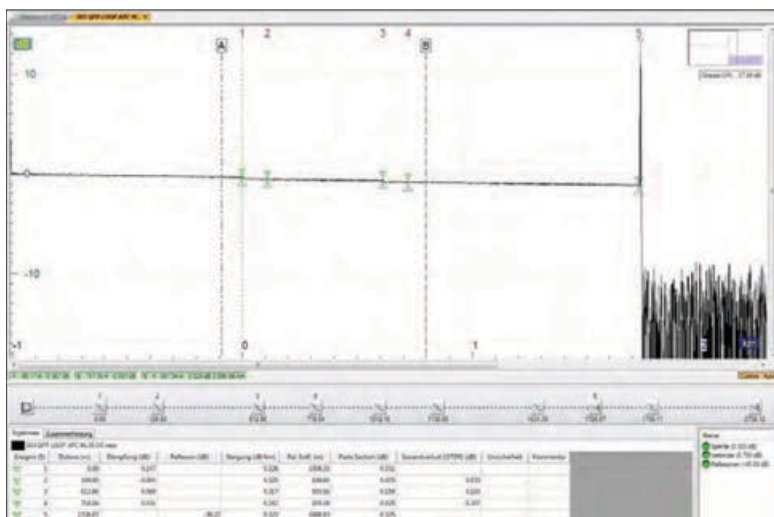

Test cables 1&2 and link 3 with APC connectors (events set and therefore visible)

Analysis of measurement results

Once the test conditions for the fiber link testing have been fulfilled it is important to analyze the results, more so when using an OTDR, as all of the elements in the link can be seen. There are 5 major elements need to be observed when analyzing an OTDR trace and if the following sequence is followed, detailed troubleshooting can be avoided where not needed. The following sequence reflects best practices and probability of most common failures.

1. Length

Check if the length of the trace is that of the combined length of the test cords and the link under test. This can already be done while the test is in progress and if the length of the trace is shorter then it is obvious the link is interrupted and faulty. If you have, for example there is a test link of 150 m and two test cords of 150m are being used then the trace should be circa 450 m. When the trace is only 300 m, there is a problem at the far side, either the polarity is wrong or there is a problem with the connector/splice. When there is a problem at this stage the testing can be stopped to solve the problem, there is no point in wasting time by running the complete test.

2. Landscape

In general high peaks in the trace should not be observed, the higher the peak the more return loss of the events there is, especially when testing a link with APC connectors. Also this analysis can be done while the test is running. If an unusually high peak is observed where there is a splice, then that splice needs to be redone. If an adapter displays a high peak this could either (and most often this is the case) indicate a dirty connector(s) or a damaged connector/adapter. Also here the test can be halted at this stage when a problem occurs.

3. Amount of events

Once the test is completed the individual events can then be viewed firstly, the amount of events need to correspond with the amount of links under test elements, i.e. amount of adaptors, splices (pigtail splices are often not detectable as they fall within the attenuation dead zone of the test equipment). Depending on the setting of the OTDR (pulse width), the attenuation dead zones become larger or smaller. For example, if there is a transmission path with pigtails at both ends and 3 events are detected, one of which is an attenuation in the middle of the transmission path, there is a problem.

5. Post-installation

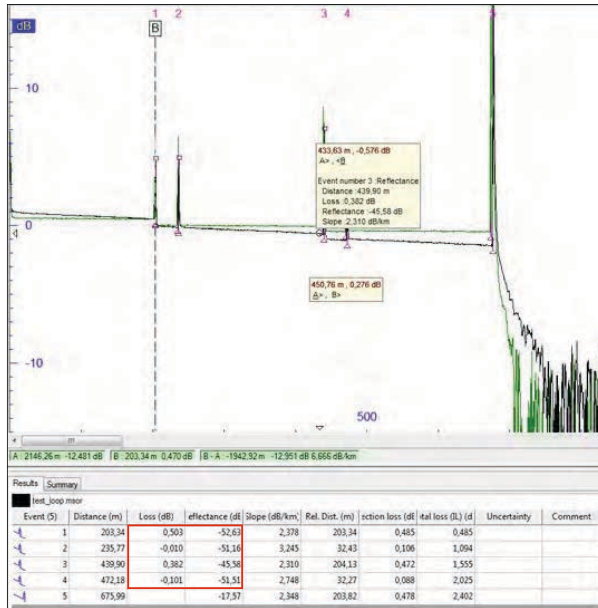

Unidirectional loop measurement

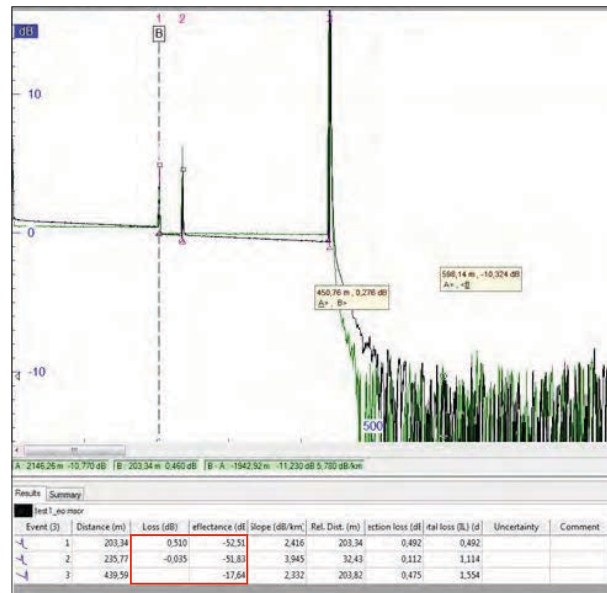

MMF measurement origin to end

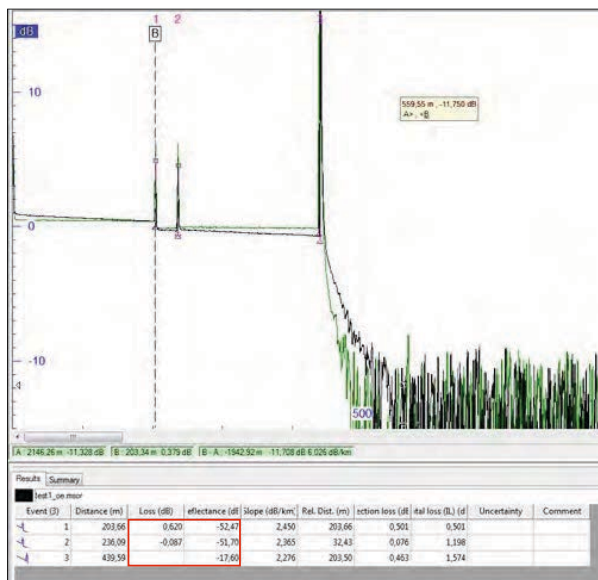

MMF measurement end to origin

4. Event Signature

Make sure that each event parameter corresponds with those given in the manufacturer datasheet. Keep in mind to take the average when performing bi-directional measurements, these are mandatory for all SMF links and allMMF links.

Measurement limits for fiber optic connectors (dB)		
Standard	ISO/IEC 11801-1 ISO/IEC 14763-3	ISO/IEC 11801-1 ISO/IEC 14763-3
Single-Mode	Attenuation (dB)	Return Loss (dB)
APC connector Reference – Reference	≤ 0.20	≥ 60
APC connector Reference – Random	≤ 0.75	≥ 60
APC connector Random – Random	≤ 0.75	≥ 60
PC connector Reference – Reference	≤ 0.20	≥ 45
PC connector Reference – Random	≤ 0.75	Not available Recommend ≥ 35
PC connector Random – Random	≤ 0.75	≥ 35
MPO Connector Random – Random	Not available Recommend ≤ 0.75	Not available Recommend ≥ 60
Multimode	Attenuation (dB)	Return Loss (dB)
PC connector Reference – Reference	≤ 0.10	≥ 35
PC connector Reference – Random	≤ 0.50	Not available Recommend ≤ 35
PC connector Random – Random	≤ 0.75	≥ 20
MPO connector Random – Random	Not available Recommend ≤ 0.75	Not available Recommend ≥ 26

R&Mfreenet connection attenuation

5. Post-installation

5. Cable

The last element to check is the cable attenuation; this might not always be possible for short links. If the link is too short to get a trustworthy reading of the cable attenuation, the total link attenuation can be considered to see if the link is ok. With SMF links, macro and micro bends will manifest themselves in increased attenuation at 1550nm and 1625nm compared to 1310nm trace signature.

Detailed Step description

Step 1

A low battery level can have a negative influence on the test results. This influence varies from test equipment to test equipment. It is therefore best practice to avoid low battery levels on the test equipment. Have the routine of charging the TE whenever there is a long break or at the end of the day. The OTDR test equipment needs about 15min of temperature acclimatization before the laser will have stable performance.

Step 2

The range shall be set in such a way it at least covers all test cords and the cabling under test, e.g. If there are 2 test cords of 500m and the longest link under test is 350m, the range will be at least 1350m or the next highest range, e.g. 2 km.

Step 3

The pulse width gives an indication of the power sent into the fiber; the larger the pulse the more power is transmitted. A wide pulse will allow further travel along the fiber, but also means that the width of the reflections becomes wider. A wider reflection will also hide more of the backscatter signal, i.e. it will increase the event and attenuation dead zone. For R&M *freenet* warranty applications it needs to be smaller than 20ns.

Step 4

The measuring time defines the time it takes to sample the link, the longer the time the better the SNR and characterization of the trace. The time chosen should allow good analysis of the cabling under test. This time is dependent upon the equipment but the general accepted min time is 20s.

Step 5

Index of refraction	850 nm	1300 nm	1310 nm	1550 nm	1625 nm
OM3/OM4/OM5	1,482	1,477			
OS2			1,467	1,467	1,468

OTDR Testing Procedure Step 5

Step 6

Save an OTDR trace of the test cords mated against each other. This test is to verify the quality of the reference connectors on the test cords, they should be better than MMF IL $\leq 0.10\text{dB}$, SMF IL $\leq 0.20\text{dB}$, PC mm/SM RL $\geq 45\text{dB}$, APC SM RL $\geq 60\text{dB}$. This step should be done daily or when replacing any of the test cords.

Step 7

Measure the Link under test, while doing this make sure the nomenclature, direction and labeling is all conformant to the requirements and standards. Check if there are no apparent defects or broken parts. It is extremely important that the file naming functions of the tester (Cable ID, Fiber number, Lambda, Direction etc.) are used and not simply rename the file name on the PC afterwards. Most OTDRs store this information in the measurement file. When renaming on the PC, this can lead to problems when evaluating via OTDR software, since without the above-mentioned file information there are difficulties in assigning the measurement results.

Step 8

Analyze the test results and check if they are conformant to the projects requirements and the known component performances. Confirm there are no defective or damaged parts. ICC of the link end faces and test cord end faces.

Step 9

Save the good test results with the correct nomenclature under the appropriate folder.

Step 10

Create the project documentation for the customer including the organized test results (see [chapter 5.3.7](#))

5.3.7 Documentation of fiber optic measurements

Unfortunately, it is often the case that the project managers or the measurement technicians think that the work is done after the measurements have been saved on the device. Unfortunately, this is not the case with fiber optic measurements, as the measurements must then be documented on the PC with the analysis software. Otherwise there is only raw data with which the customer cannot really do much.

Using Fluke as an example, the associated software for evaluation is the familiar linkware. The measured files are loaded from the device to the PC and processed with Linkware. The software now enables the measurements to be checked and is in a clean order with documentation of the measured project.

The multitude of fiber optic measuring instruments available today also brings with it a multitude of evaluation software. Basically, the purchase of a fiber optic measuring device should be accompanied by the appropriate evaluation software. Even more important is training on how to use this software correctly. Please contact the instrument vendor if training has not been received on the appropriate evaluation software or contact them directly if a new instrument is purchased.

Documentation procedure of fiber optic measurements

The measurements are to be imported from the instrument into the software. Once the measurements have been made as described in [chapter 5.3.5](#), most of the work has already been done. When documenting OTDR and LSPM measurements, the following points must be observed. For LSPM measurements, various steps of the procedure listed below can be neglected.

Step	Description
1.	Import the measurement data and open with the editing software.
2.	Set the limits required by the standard in the software or set the limits according customer-specific limit values. For warranty requests we require that at least the limit values of the measuring standard ISO/IEC 14763-3 and ISO/IEC 11801-1 are observed.
3.	Check the events and edit them if necessary. In OTDR measurements, it can happen that the OTDR does not recognize all events automatically. Singlemode APC connections are often so good that no event is detected.
4.	See that for bi-directional measurements the averaging of the measured values can be done. If the events are not set in the correct place, the program cannot carry out the averaging of the values. In this case, repeat step 3 for the relevant measurements.
5.	Place the cursor A-B / B-A at the beginning and end of the measured link. Start = transition from launch lead to fiber link / end = transition from fiber link to tail lead
6.	Perform steps 3-4 for each fiber tested. Most evaluation diagrams can take over the events of one fiber for another to save time, as long as they have the same properties and events.
7.	Check that all fibers meet the required set limits.
8.	Use the software to create a report of the project being worked on. Practically all evaluation programs can generate PDF's and EXCEL tables. Use this function to provide the customer with clean documentation.
9.	Add the desired project descriptions and company information to the report. Create a title page or a general overview as desired or specified by the customer.
10.	Create a collective directory or a zip in which you collect the measurement files and the documentation of the project. Hand them over to the customer and to R&M for the warranty claims.

Fiber optic documentation procedure

6. Glossary

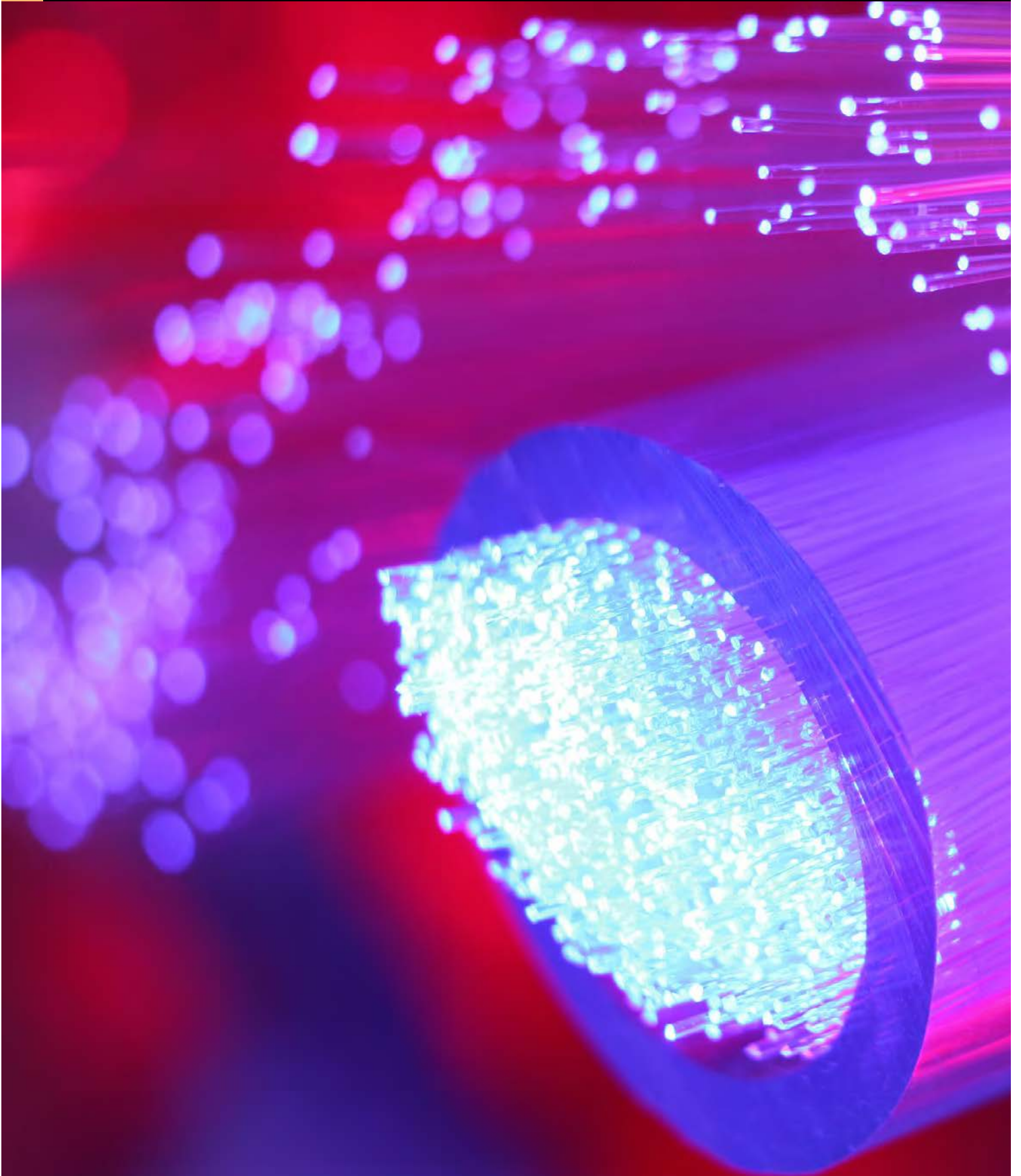

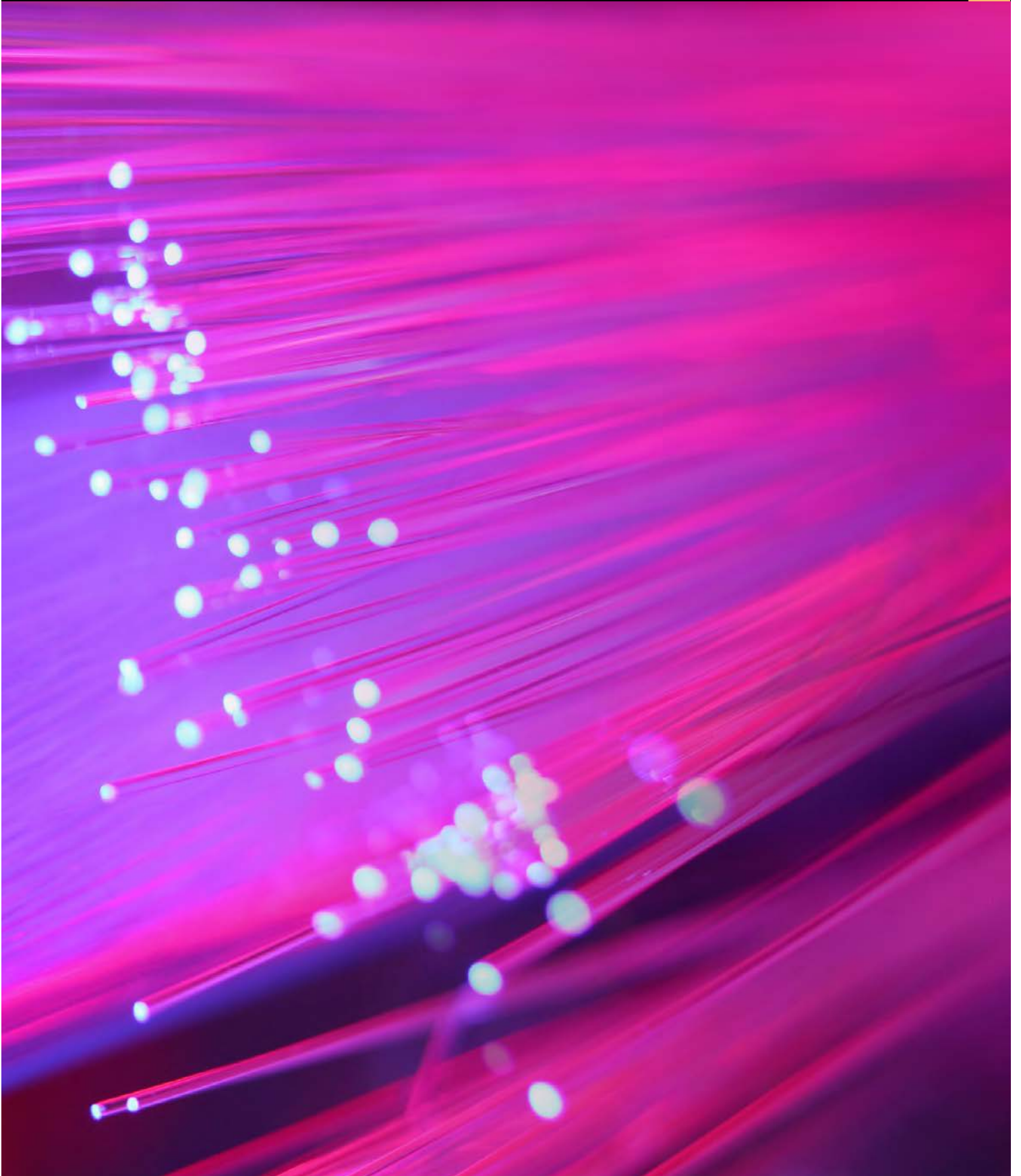

6. Glossary

A

ACR (Attenuation to Crosstalk Ratio)

The difference between NEXT and attenuation, measured in dB. A high ACR value indicates that the received signals are much stronger than crosstalk, corresponding to a high NEXT value and low attenuation.

American National Standards Institute (ANSI)

National standardization body of the U.S. ANSI develops and publishes standards, and is the American representative on and voting member of the ISO.

American Wire Gauge (AWG)

The U.S. American standard gauge to specify the diameters of conductors made of copper, aluminum and other materials.

AWG	18	19	20	21	22	23	24	25	26	27	28	29	30
Ø (mm)	1.013	0.866	0.772	0.688	0.610	0.546	0.485	0.432	0.384	0.358	0.318	0.284	0.251

Alien Near/Far End Crosstalk (ANEXT/AFEXT)

Alien crosstalk (AXT) is electromagnetic noise that can occur in a cable that runs alongside one or more other signal-carrying cables and is detected or measured at the near or far end of the victim link. The term «alien» arises from the fact that this form of crosstalk occurs between different cables in a group or bundle, rather than between individual wires or circuits within a single cable

Application Independent Cabling

A structured telecommunications cabling system supporting many different applications. It is not necessary to know the applications when installing application independent cabling. It does not include application-specific hardware.

Attenuation

The decrease in magnitude of a signal as it travels through a transmission medium.

B

Bandwidth

The range of frequency available for the transmission of information over a channel. The value indicates the transmission capacity of a channel. The higher the bandwidth, the more information can be carried. It is expressed in Hertz (Hz) or Bit/s or MHz.km (with optical fibers).

Bending Radius

The radius of curvature that a fiber-optic or copper cable can bend before the risk of breakage or increased attenuation occurs.

Bit Error Rate (BER)

Measure to indicate the quality of a digital transmission link. The value is expressed as a percentage or ratio of received bits that are in error, typically 1 error in 10⁸ or 10⁹ transmitted bits. The less bit errors occur, the better the quality of the connection.

C

Cable Route

Determined cable route and/or attachment in false floors and ceilings.

Cabling System

A system of telecommunications cables, conduits and connecting hardware, interconnected via IT equipment.

Capacitance

The ability and dielectric behavior of conductors to store electric charge between two conductors separated by a dielectric material in case of potential difference. Capacitance is not welcome in copper cables because it interferes with the transmitted signals by impeding the intended current flow.

Category 3

Industry standard for cables and connecting hardware with transmission parameters specified up to 16 MHz, mainly for data rates of up to 10 Mbit/s.

Category 5, 5e

An enhanced version of Category 5, since 1999, specifying additional parameters to allow full-duplex transmission over 4 conductor pairs. Enhanced Category 5 for cables and connecting hardware with transmission parameters specified up to 100 MHz, to support data rates of up to 1000 Mbit/s.

Category 6

Industry standard for cables and connecting hardware with transmission parameters specified up to 250 MHz, for data rates of up to 1 Gbps and above.

Category 6_A

Industry standard for cables and connecting hardware with transmission parameters specified up to 500 MHz, for data rates of up to 10 Gbps and above.

Category 7

For cables and connecting hardware with transmission parameters specified up to 600 MHz. Category 7 specifies only cables and requires new plugs to allow unimpeded transmission at the above mentioned frequencies.

Category 7_A

For cables and connecting hardware with transmission parameters specified up to 1000 MHz. Category 7A specifies only cables and requires new plugs to allow unimpeded transmission at the above mentioned frequencies.

Category 8.1 & 8.2

Industry standard for cables and connecting hardware with transmission parameters specified up to 2000MHz.

CENELEC

The European Committee for Electro technical Standardization.

CENELEC EN 50173

European standard, developed by CENELEC, for the planning and installation of information technology cabling systems.

Channel

The end-to-end transmission path between two points at which application specific equipment is connected. The connection cables of the technical equipment and the workplace are also part of the channel.

Connection Cable

A patch cable connecting terminal equipment and the workplace outlet.

Consolidation Point

A point of interconnection between horizontal cables, mainly for convenience reasons, when furniture is rearranged

6. Glossary

Cross-Connect

A cable cross-connect facility within a structured cabling system, where the communication connections are administered (i.e. where the adding and reconfiguring of connections by means of patch cables is carried out).

Crosstalk

Mutual electromagnetic influencing of two physically separated current circuits of a system, when a signal in one circuit creates a noise voltage in the adjacent circuit disturbing the transmitted signals there.

D

Decibel (dB)

The unit for measuring the relative increase/decrease of a signal, voltage or current, expressed as a logarithmic ratio.

Delay Skew

The difference in propagation delay between two pairs of the same cable.

E

Electromagnetic Compatibility (EMC)

EMC, electromagnetic compatibility, denotes the capability of electronic equipment, an installation or a system, to function satisfactorily in an electromagnetic environment. In addition, this equipment (installation, system) should not cause any electromagnetic interference that would be intolerable for any devices, systems and installations in this environment.

Equal Level Far End Crosstalk (ACR-F)

Identical to FEXT with the exception that the coupled signal at the far end is related to the attenuated signal at the far end of the conductor pair, into whose near end the signal was fed.

Equipment Outlet

Fixed connecting device for terminating the zone distribution cabling and providing the interface to the equipment cabling

Equipment Room (ER)

Room dedicated to housing distributors and application specific equipment

F

Far End Crosstalk (FEXT)

Describes the unwanted coupling of signals from the transmitting conductor pair to the receiving conductor pair at the far end of the line. FEXT is also expressed in dB. Its value is only important for selected applications. In general, near end crosstalk, NEXT, is more important.

Fixed zone distribution cable

Cable connecting the zone distributor to either the equipment outlet or, if present, the local distribution point

Frequency

The number of times a periodic action occurs within a certain time. Expressed in hertz (Hz).

H

Hertz (Hz)

The standard unit of frequency, one cycle per second.

Horizontal Cable

The cable connecting the floor distributor to the telecommunications outlets.

I

Impedance

A frequency-dependent resistance (characteristic impedance) in a transmission link indicating the total opposition offered to the flow of current.

Interference

Any signal distortion caused by an extraneous, undesired signal.

ISO/IEC 11801

The international standard for application independent cabling systems.

J

Jacket

The flexible, outer covering of a cable, protecting the color-coded conductors inside.

L

Lay Length

The lay length measures the twisting of twisted pair cables. Two individual conductors are twisted into a pair. A change in the lay length can improve the NEXT values.

Local Area Network (LAN)

A data communications system consisting of host computers and other computers interconnected with terminal equipment (e.g. PCs). Frequently cabled with twisted-pair or coaxial cables. A LAN allows several users shared access to data and resources. A LAN is usually restricted to one building.

Local distribution point

Connection point in the zone distribution cabling subsystem between a zone distributor and an equipment outlet

Local distribution point link

Transmission path between a local distribution point and the interface at the other end of the fixed zone distribution cable including the connecting hardware at each end

M

Main distribution cable

Cable connecting the main distributor to the zone distributor

Main distributor

Distributor used to make connections between the main distribution cabling subsystem, network access cabling subsystem and cabling subsystems specified in ISO/IEC 11801 and active equipment

N

Near End Crosstalk (NEXT)

The disturbing signal coupling from the transmitting pair to the receiving pair, at the same end (= near end) of the link. NEXT is expressed in dB. It is an indication of how well the pairs are decoupled from each other.

6. Glossary

Network

The local and long-distance telecommunications capability provided by common carriers for switch and private line telecommunications services. A system of software and hardware connected in a manner to support data transmission.

Network access cable

Cable connecting the external network interface to the main distributor or zone distributor

Network Architecture

Topology and structure of a network.

Noise

Referring to any extraneous signal, which interferes with the desired signal from a different source than the connected transmitter. Noise interference can degrade a signal as badly as making it unrecognizable for the receiver. The higher the data rate, the stronger the interference's effect.

Nominal Velocity of Propagation (NVP)

When signals travel down a physical medium their speed is below the speed of light and dependent on the medium's material and design. The NVP indicates the signals' speed in the physical medium relative to the speed of light in a vacuum. Typically, copper cable results show 60% to 85% of the speed of light.

P

Pair (Conductor Pair)

Two conductors, paired together (mostly by twisting) and color-coded. See also Symmetrical Twisted Pair Cable.

Permanent Link

The transmission link between two interfaces of an application independent cabling system, excluding connection cable and workplace cable.

Power Sum

A procedure of crosstalk testing and measuring in multi-pair cables, referring to the summing of various forms of disturbing crosstalk, with all the other pairs active.

Propagation Time Delay

A signal that travels from one point of a transmission link to another experiences a certain time delay. It is calculated on the basis of the cable length and the velocity of propagation specified for the transmission medium.

R

Resistance

The characteristic of a conductor defining the current flow generated at a given potential difference. It opposes the current flow and causes loss of performance in the form of heat. Resistance is measured in ohms.

Return Loss

Return loss indicates impedance regularity along the cable as well as in plug connector and patch cable.

S

Shield

A metallic cover around the insulated conductors of a shielded cable. The shield can be a cable's metallic jacket or the metallic layer of a metal-free jacket. Also referred to as screen.

Shielded Twisted Pair Cable (STP)

Generic term for a copper data transmission cable that incorporates metallic shielding either around 4 twisted pairs of insulated copper wires, or individually around each twisted pair in a cable (or a combination of both).

Symmetrical Twisted Pair Cable

A cable consisting of at least one symmetrical cable (twisted pair or star-quad).

T

Telecommunications Outlet (TO)

The term to denote the data outlets installed at workplaces within a structured cabling system. Either copper or fiber connectivity may be used for supporting numerous different services (e.g. voice, video and data).

Telecommunications Room

Enclosed space for housing telecommunications equipment, cable terminations, interconnect and cross-connect

Tensile Force

The force measured in Newton (N) that a cable is exposed to during installation (10N ~1 kg)

TIA

Telecommunications Industry Association, North American standardization organization.

TIA 568x

The North American standard for telecommunications cabling in office buildings.

U

Unshielded Twisted Pair Cable (UTP)

Generic term for a copper data transmission cable using multiples of insulated twisted copper wires without further metallic shielding of the wire pairs or the cable as a whole

W

Wire Map Test

The wire map test checks if the connector modules' pin assignment is identical at both ends.

Workplace

A space in a building where users work at telecommunications terminals. A typical workplace measures 9 square meters.

Z

Zone distribution cable

Cable connecting the zone distributor to the equipment outlet(s) or local distribution point(s)

Zone distributor

Distributor used to make connections between the main distribution cabling subsystem, zone distribution cabling subsystem, network access cabling subsystem and cabling subsystems specified in ISO/IEC 11801 series and active equipment

7. Abbreviations

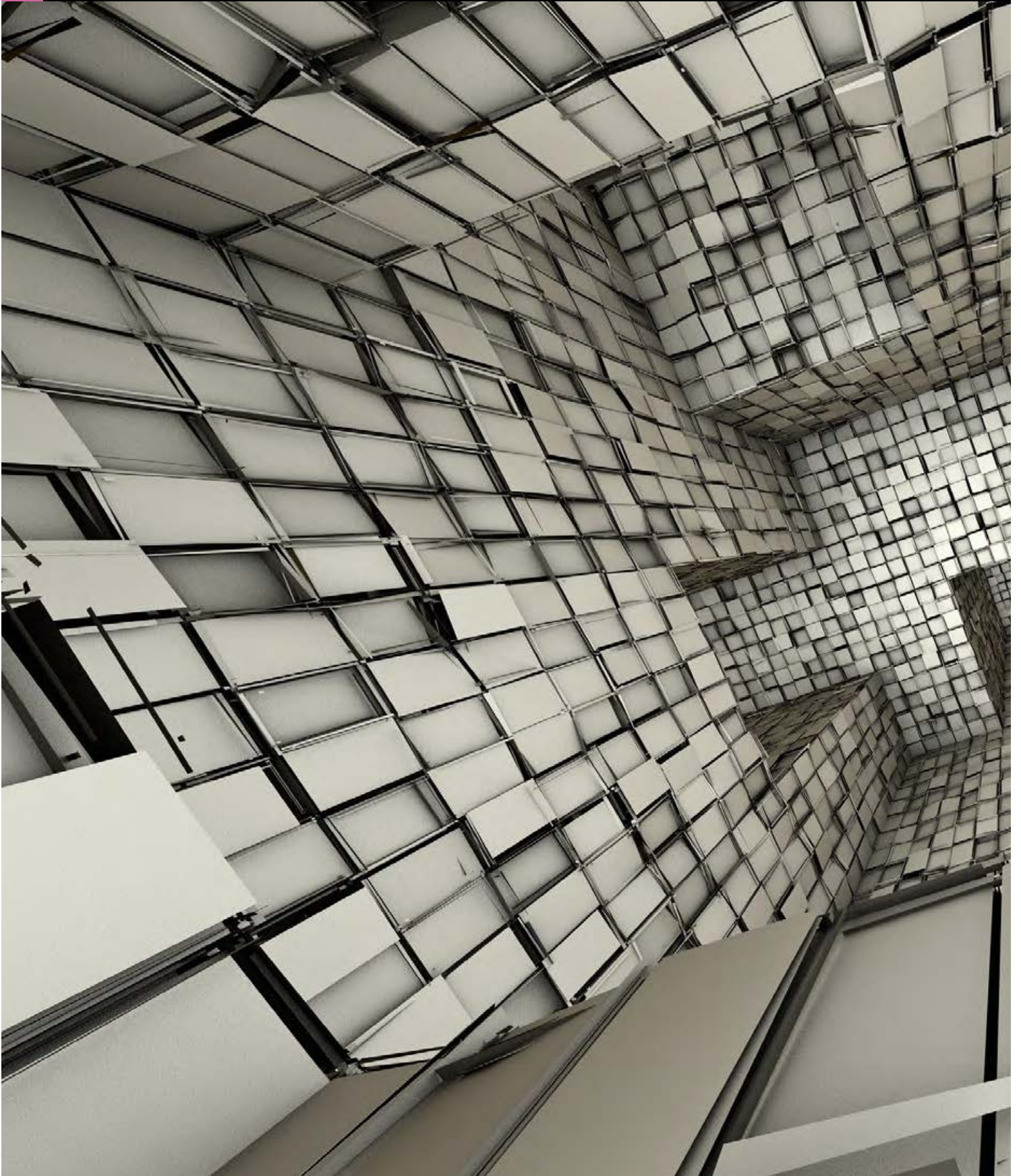

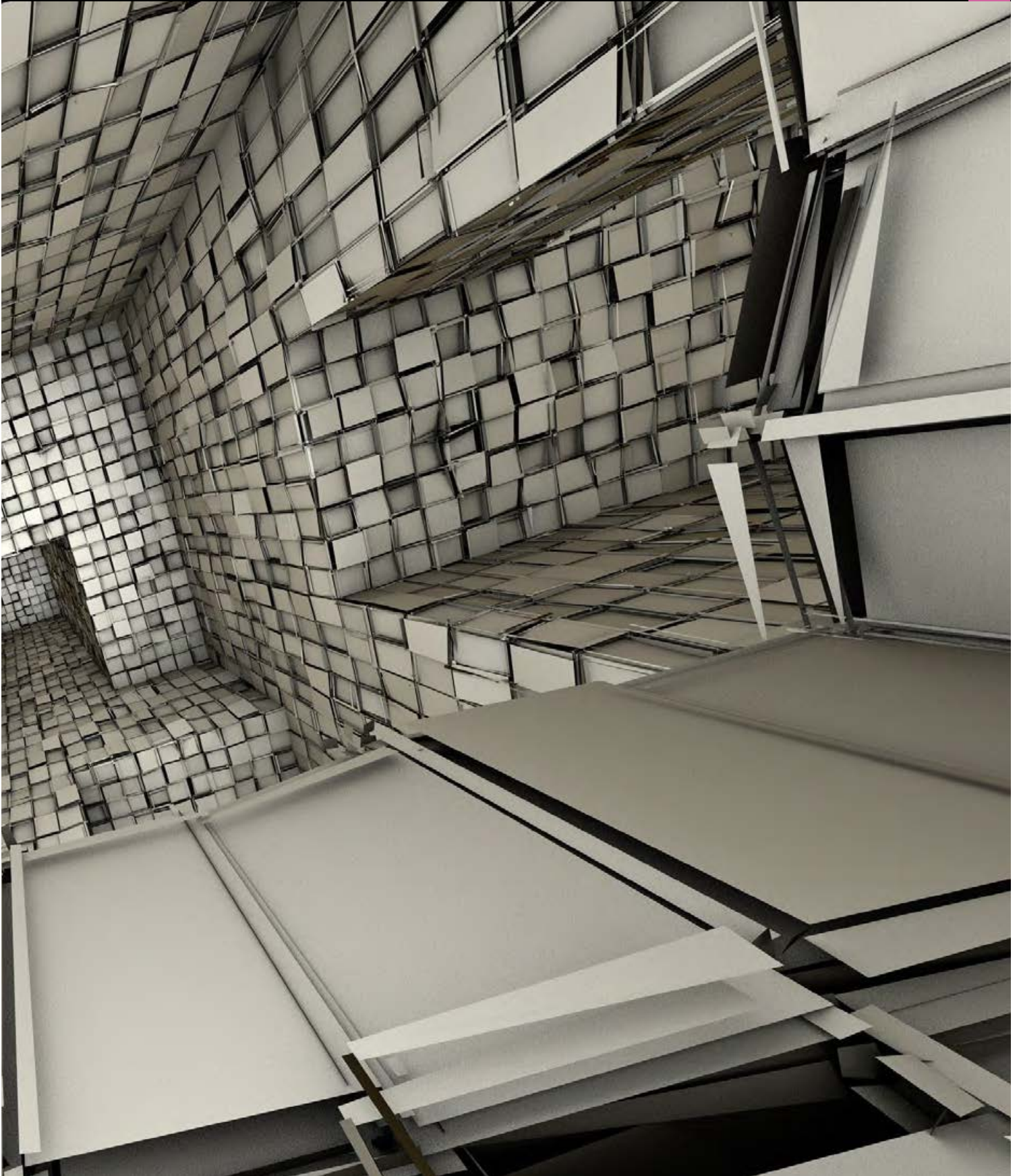

7. Abbreviations

Abbreviation	Description
AC	Alternate Current
APC	Angled Physical Contact
BN	Bonded Network
CBN	Central Bonded Network
CRAC	Computer Room Air Conditioner
DC	Direct Current
DC-I	DC Isolated distribution system
DC-C	DC Common distribution system
EMC	Electro-Magnetic Compatibility
ER	Equipment Room
HF	High Frequency
ICC	Inspect Clean Connect
MEP	Mechanical, Electrical and Plumbing
MMF	Multi Mode Fiber
MPO	Multi-fiber Push-On connector
OLT	Optical Line Terminal
OTDR	Optical Time Domain Reflectometer
LSPM / OLTS	Light Source Power Meter / Optical Loss Test Set
ONT	Optical Network Terminal
OTO	Optical Telecommunication Outlet
PC	Physical Contact
PE	Protective Earth
PoE	Power over Ethernet
RCD	Residual-Current Device or residual-current circuit breaker (RCCB)
SMF	Single Mode Fiber
SNR	Singal to Noise Ratio

Abbreviation	Description
TN-C	A combined PEN conductor fulfils the functions of both a PE and an N conductor
TN-C-S	Part of the system uses a combined PEN conductor, which is at some point split up into separate PE and N lines
TN-S	PE and N are separate conductors that are connected together only near the power source
TT	In a TT (Terra-Terra) earthing system, the protective earth connection for the consumer is provided by a local earth electrode, and there is another independently installed at the generator
UPS	Uninterruptible Power Supply

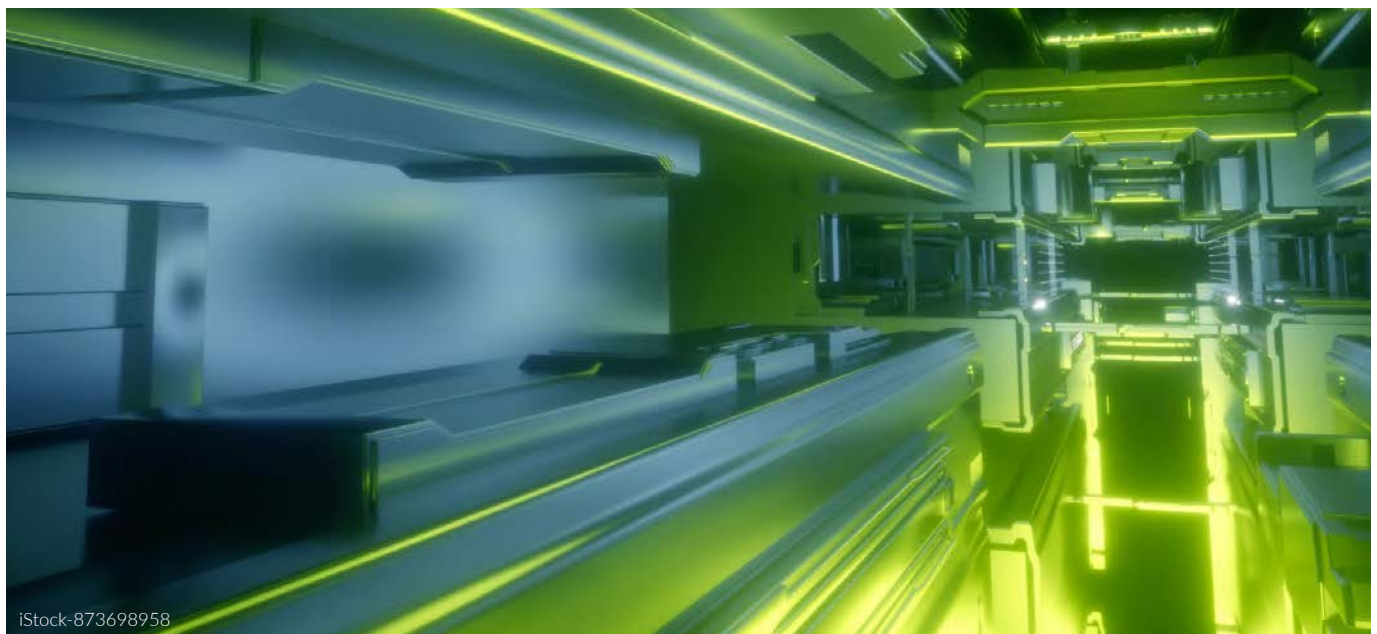

iStock-873698958

8. Picture Key

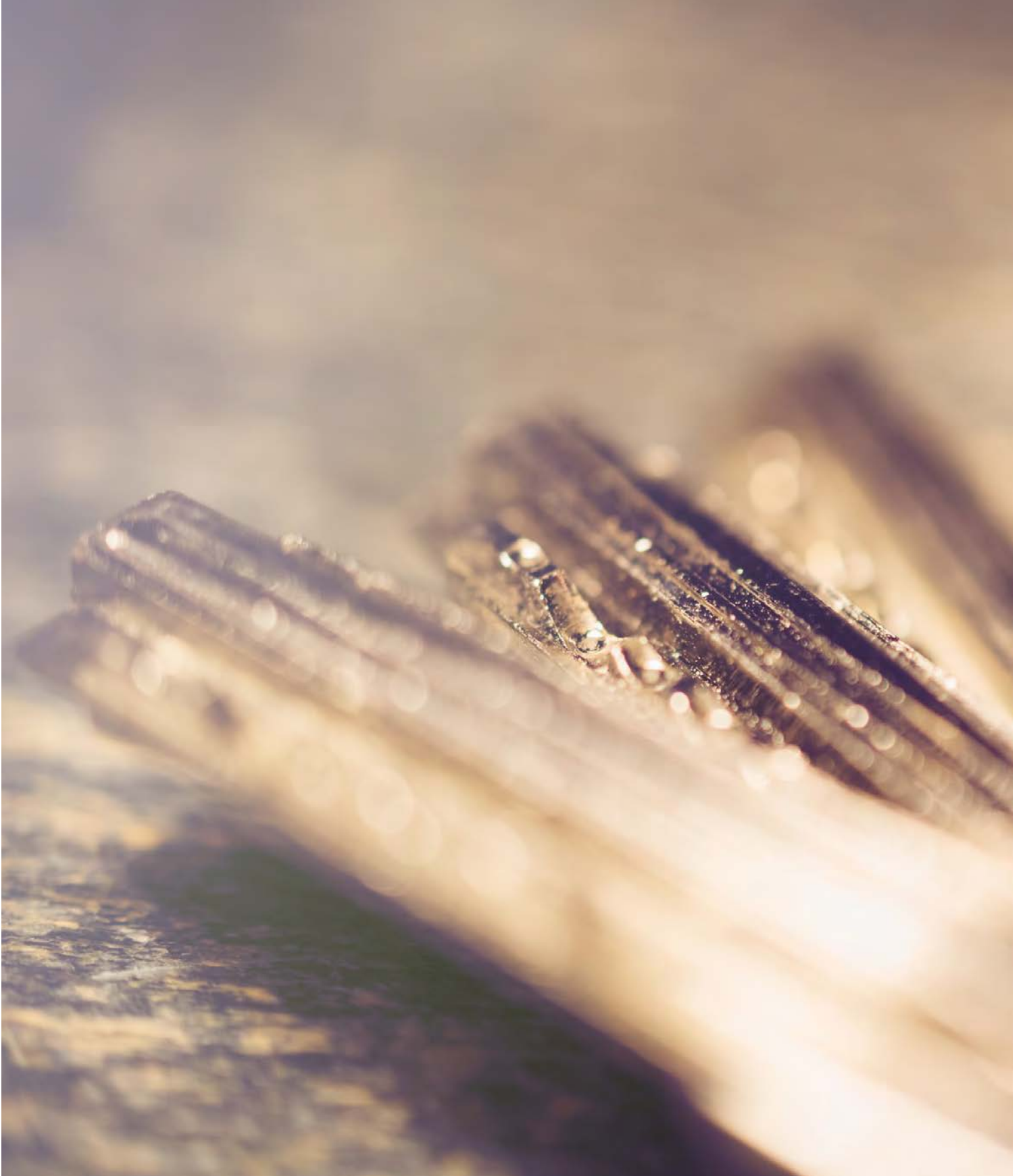

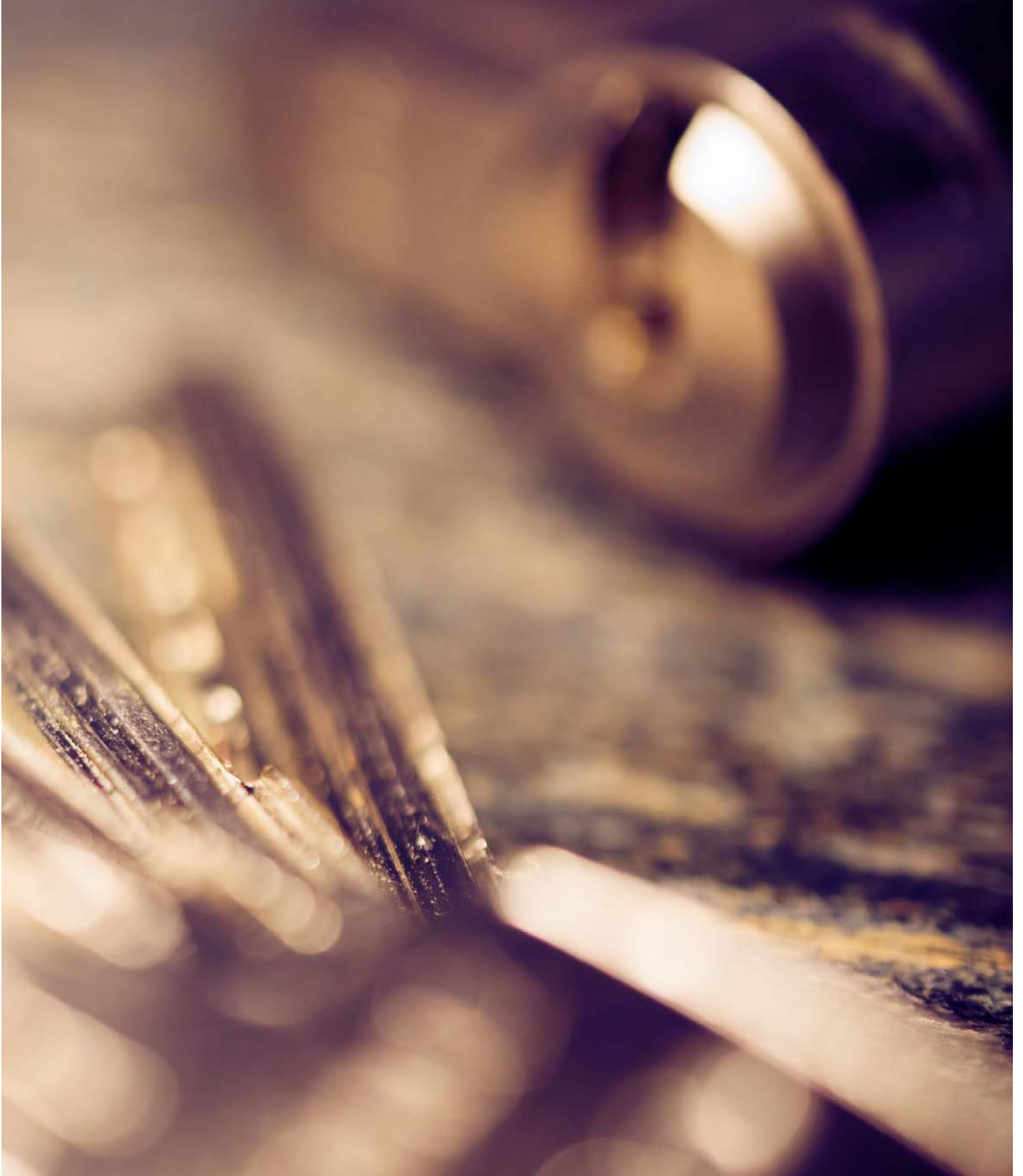

8. Picture Key

Key	Description
A	Adapter
BD	Building Distributor
C	Connection / Connector
CD	Campus Distributor
Core	Core Switch Equipment
CP	Consolidation Point
EF	Encircled Flux
EO	Equipment Outlet
EQP	Active Equipment
FD	Floor Distributor
J	Joint (R&M Cable Coupler)
LDP	Local Distribution Point
MD	Main Distributor
MPO	MPO Connector
OLT	Optical network Line Terminal
ONT	Optical Network Termination
P	Plug
PP	Patch Panel
Rx	Receive
Spl	Splice
SVR	Server
TE	Terminal Equipment
TO	Telecommunication Outlet
Tx	Transmit
ZD	Zone Distributor

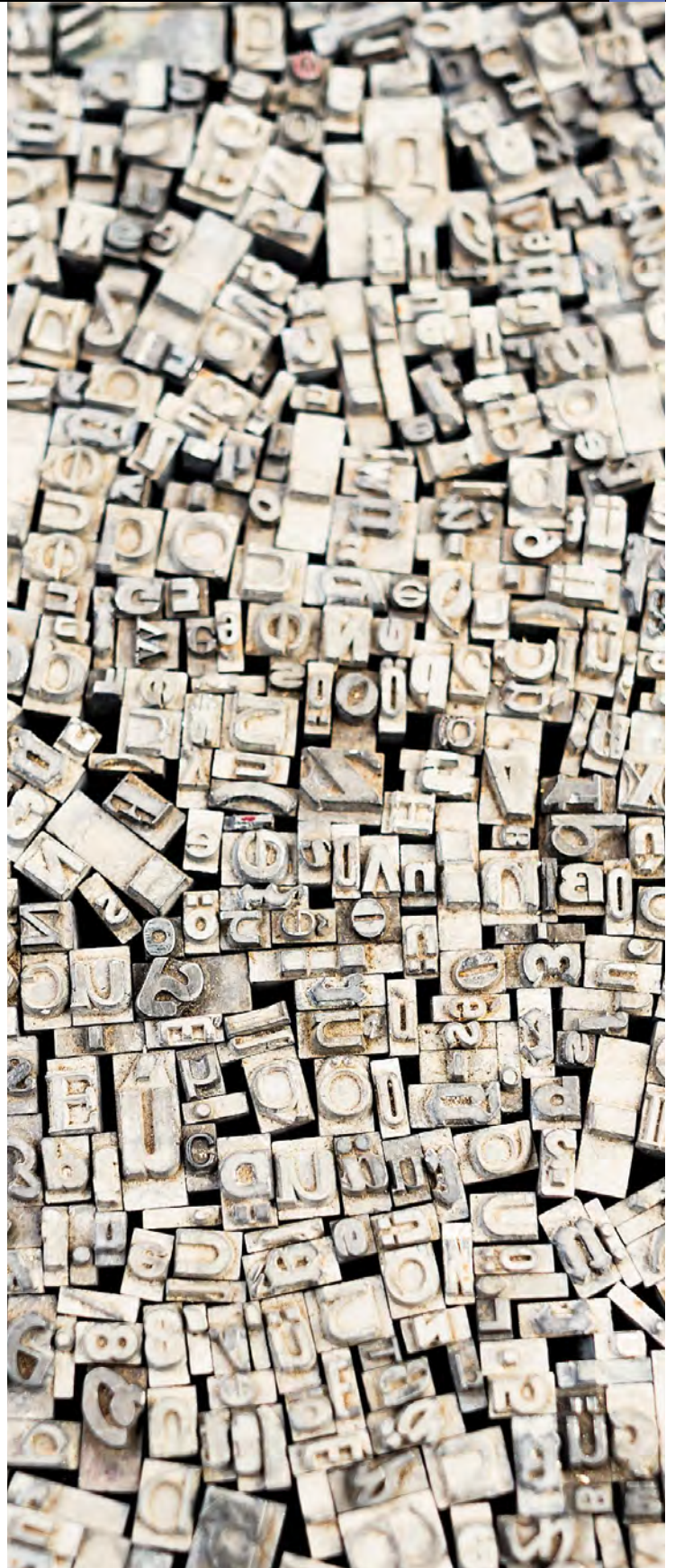

9. List of Tables

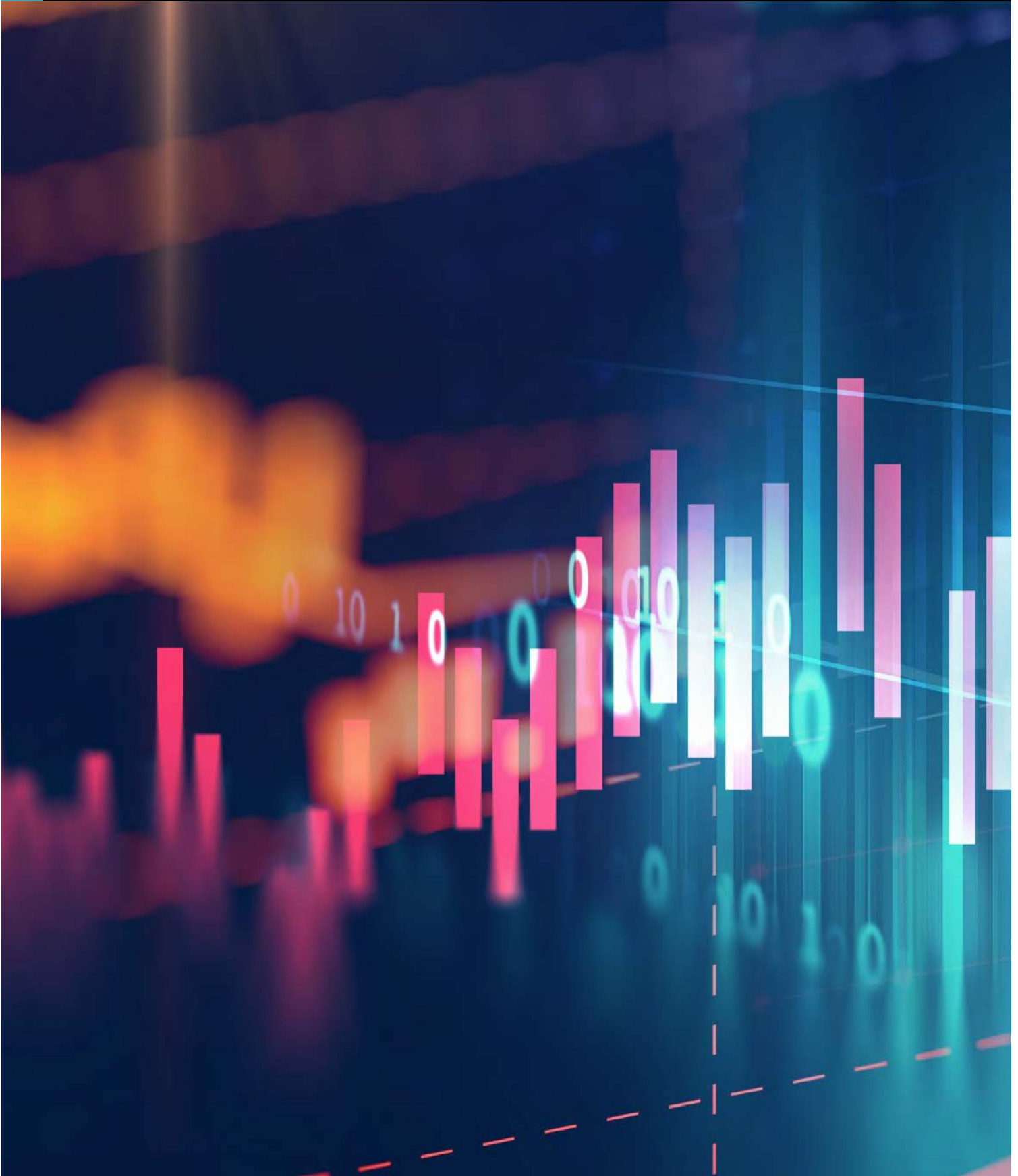



9. List of Tables

Project Quality Assurance, part 1	20
Project Quality Assurance, part 2	21
ISO Standard	24
TIA Standard	25
TIA Standard	25
EN Standard	26
CPR Classes & criteria	29
CPR Additional classes and fire protection levels	30
EMC power distribution	34
Standard differences	37
R&M <i>freenet</i> Connector Link Classification	37
TP cable structure	38
Example data sheet – copper cable	40
Horizontal cabling link equation	41
ISO/IEC 11801 reference cabling lengths	41
Interconnect-TO equation	42
Cross connect-TO equation	42
Interconnect-CP-TO equation	43
Cross connectCP-TO equation	44
Interconnect-EO equation	45
Cross connect-EO equation	45
Interconnect-LDP-EO equation	46
Cross connect-LDP-EO equation	46
Main distributor channel equation	47
R&M <i>freenet</i> AWG26 maximum horizontal length	48
R&M <i>freenet</i> IEEE maximum horizontal length	49
R&M <i>freenet</i> IEEE maximum horizontal length for custom cable	49
R&M <i>freenet</i> Cat. 6 _A ISO minimum horizontal length	50
R&M <i>freenet</i> Cat. 6 _A EL minimum horizontal length	50
One connector equation	51
One connector equation	52
BtB model equation	52
Cross-inter-cross model equation	53
Classification of information technology cables according EN 50174-2	60
Minimum separation S according EN 50174-2	60
Separation requirements between metallic cabling and specific EMI sources according EN 50174-2	61
Length restrictions for Class I / Cat. 8	73
Components requirements for standards	75

IEEE applications supported MMF (ISO/IEC 11801-1)	77
IEEE Applications supported SMF (ISO/IEC 11801-1)	78
FO connector types – part 1	79
FO connector types – part 2	80
FO connector types – part 3	81
Fiber adapter types – part 1	82
Fiber adapter types – part 2	83
IL Grades according IEC 61753-1	84
RL Grade according IEC 61752-1	84
FO connector IL vs RL	85
ISO11801-1 cable attenuation	85
R&M <i>freenet</i> FO cable loss	86
Fiber cable types	87
Fiber cable construction – part 1	88
Fiber cable construction – part 2	89
IEEE802.3 GPON power budget	95
R&M splitter performance	95
FO installation cable color codes	98
Sample copper cabling bending radius	116
Termination of modules	119
Laser class overview according to IEC 60825 Ed. 3.0:2013	123
Primary treatments Isopropanol & Hexane	125
FO cable tensile strength	127
FO cable bending radius	128
Test equipment measurement tolerance	136
Test equipment accepted for warranty applications	138
Test equipment standard selection	139
Test equipment adapter selection	140
ISO 61300-3-35 criteria	151
Reference-Reference mating loss budget	154
Reference/random mating loss budget	155
FO cable index of refraction	157
FO cable index of refraction	164
R&M <i>freenet</i> connection attenuation	169
OTDR Testing Procedure Step 5	170
Fiber optic documentation procedure	173

10. List of Figures

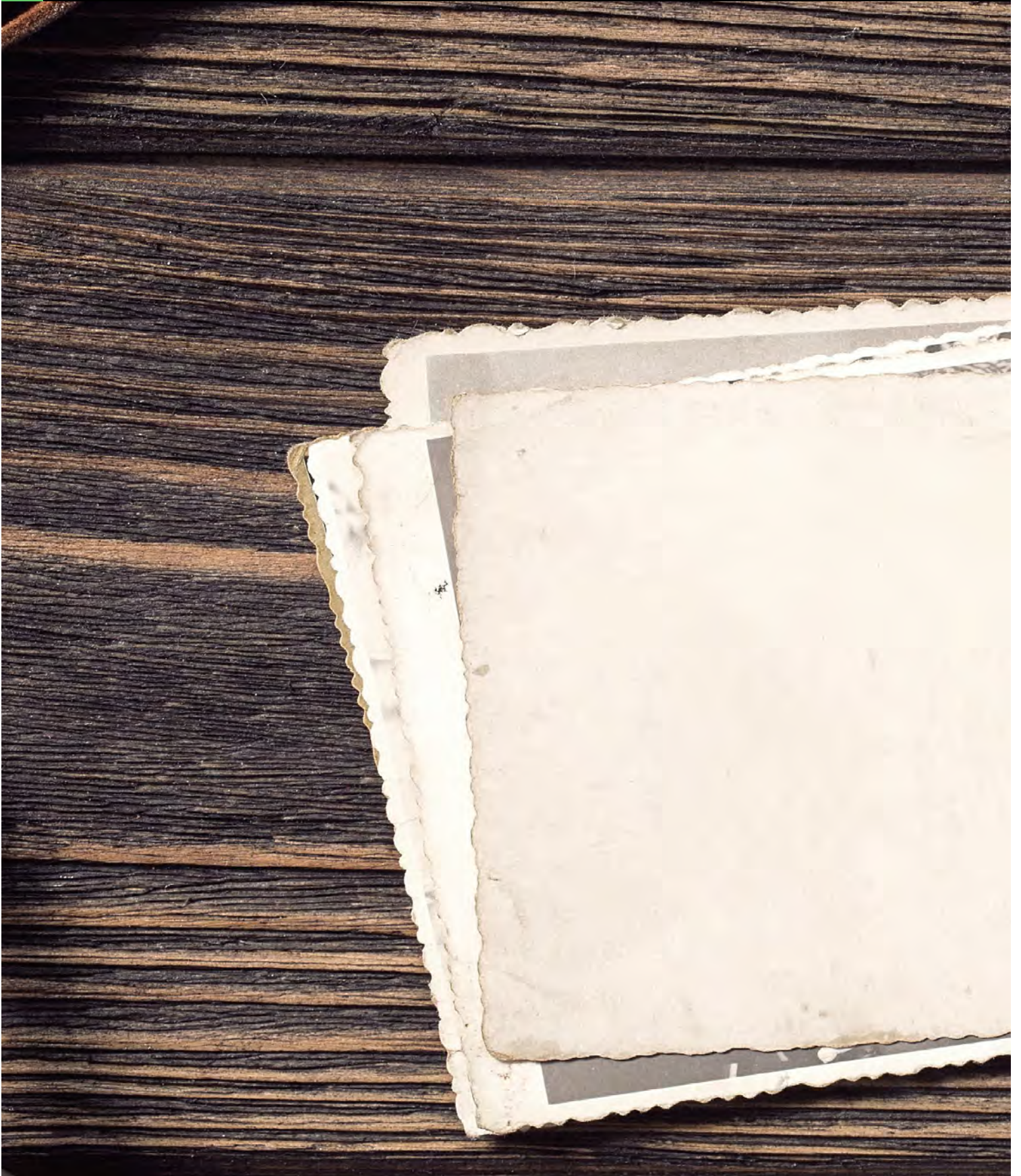

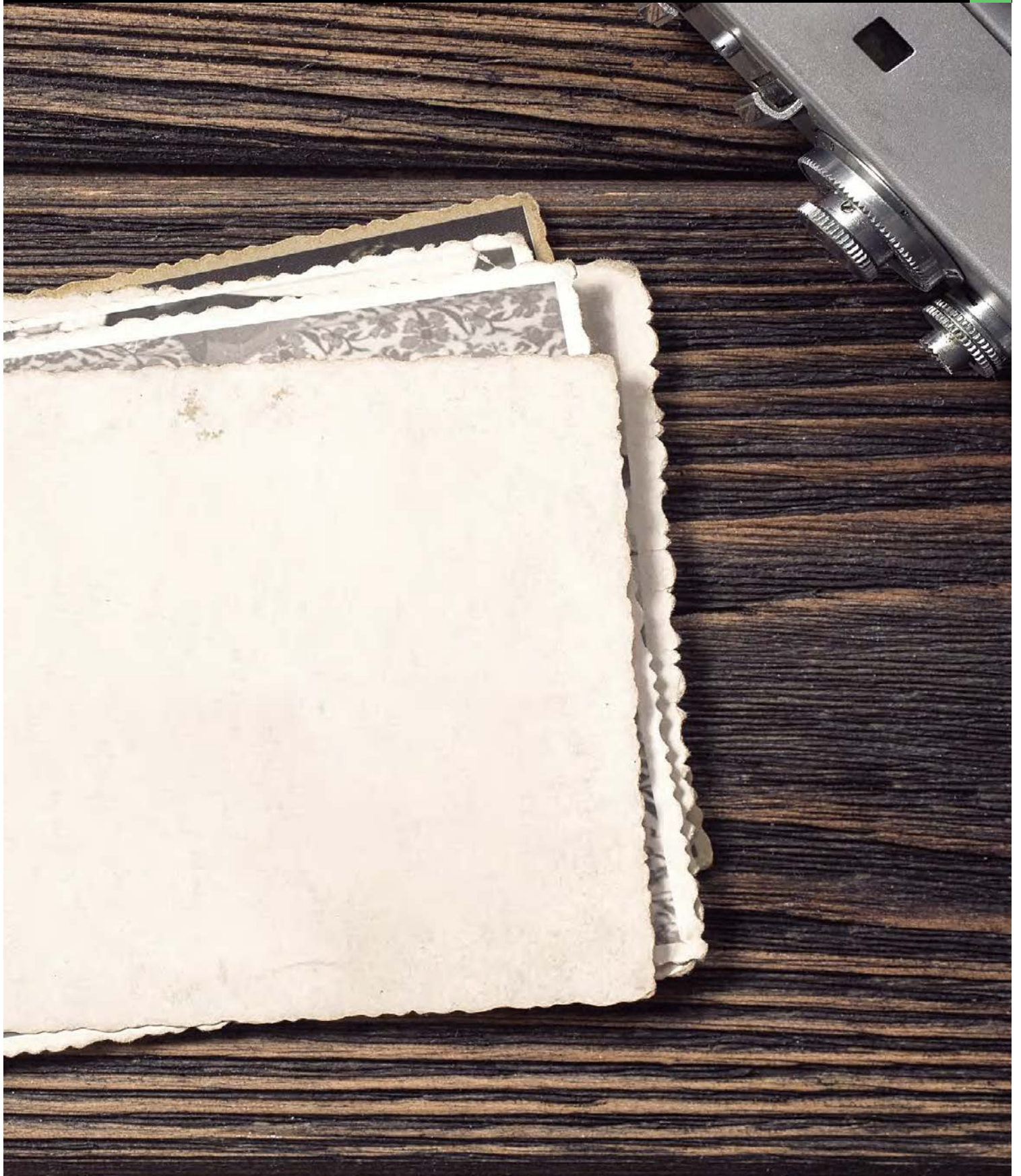

10. List of Figures

MICE classification	27
Premises earthing	32
EN 50310 Minimum	32
EN50310 Recommended	33
Bonding Concept R&M Panels	35
Interconnect-TO model	42
Interconnect-TO model	42
Interconnect-CP-TO model	43
Cross connect-CP-TP model	44
Interconnect-EO model	45
Cross connect-EO model	45
Interconnect-LDP-EO model	46
Cross connect-LDP-EO model	46
Main Distributor channel model	47
LAN one connector model	51
DC one connector model	51
OC/DC 1-Connector Model MPTL with Cable-Coupler	52
BtB interconnect model	52
Cross-inter-cross connection model	53
Interconnect TO/EO model with RJ45 Coupler	56
Coupled PL Indoor/Outdoor MPTL with Cable Coupler	56
Cross connect TO/EO model with RJ45 Coupler	56
Interconnect LDP EO model with RJ45 Coupler	57
Cross connect LDP EO model with RJ45 Coupler	57
Heat distribution with PoE	63
IPC contact	64
Resistance behavior	65
IDC contact	65
Spark when disconnection under load	66
Displacement contact point during plugging process	67
TCL influence	68
Good contact design	68
EMC radiation	69
Length restrictions 25G-ready	71
Sample test PL	72
Sample test 25G	72
Schematic representation of Cat. 8.1 channel with length specification	74
FO sample calculation LAN	90
FO sample Calculation DC	90

FO 3 Connector direct combined	91
FO 4 connector combined splice	91
FO 5 connector direct combined	92
Principal scheme for POLAN	93
POLAN sample configuration	94
POLAN calculation sample	96
Products for the realization of a POLAN	97
OF patch cord polarity	98
FO crossed backbone polarity	100
FO straight backbone polarity	101
Key Up and Key Down	102
MPO Type A and MPO Type B Cables	102
MPO polarity method A components	103
MPO polarity method A fan-out	103
MPO polarity method A 40/100G	104
MPO polarity method with R&M fan-out Trunk B	105
MPO polarity method R&M 40/100G Trunk B	105
MPO polarity method with R&M fan-out Trunk A	106
MPO polarity method R&M 40/100G Trunk A	106
Copper cable stored in good conditions	111
Copper cable stored in the wrong conditions	111
Unloading reel with bar	112
Correct lifting procedure	112
Correct cable routing	114
Proper direction for unrolling	115
Wrong direction for unrolling	115
Proper vertical riser installation	116
Correct fastening of vertical cables	116
Copper cable installation pulley	116
Cable management examples	117
Tools for terminating copper cables	118
Correct wiring	120
Incorrect wiring	120
Cabinet aisle protection	126
Efficient cable management	128
Tools for preparation and termination of fiber cables	129
LC APC connector FO Field	130
Assembled FO Field connector	131
Patch cable management with R&M ODF system	132

10. List of Figures

Patch cables with R&M's Netscale	132
Sample test link PL	141
Sample test link CH	141
Sample test link MPTL	141
Sample test link PL with CP Method 1	142
Sample test link PL with CP Method 2	142
Measurement Evaluation Analysis	143
FO Cabling Permanent Link Configuration	147
FO Channel test configuration	148
Direct test not possible through splitter	149
Split installation in two parts and test main cable And each outlet individually	149
Most Common Faults in Fiber Optic Installations	150
ISO 61300-3-35 SMF & MMF	150
Examples of cleaned fiber optic connector surfaces	151
Fiber endface cleaning equipment	152
Fiber endface inspection tool	152
«one Jumper» reference method	158
«one Jumper» method verification	159
«extended 3-Jumper» method verification	159
Measurement of a PL	160
Measurement of a CH	160
OTDR Loop measurement A to B	163
OTDR Loop measurement B to A	163
Test leads and loop reference connector verification	165
Test lead 1 & 2 reference connector verification	165
Test cables 1 & 2 and link 3 with APC connectors (events not set, i.e. not visible)	166
Test cables 1 & 2 and link 3 with APC connectors (events set and therefore visible)	166
Unidirectional loop measurement	168
MMF measurement end to origin	168
MMF measurement origin to end	168







Headquarters

Switzerland
Reichle & De-Massari AG
Binzstrasse 32
CH-8620 Wetzikon

www.rdm.com

Please choose your country
on our global website

R&M Blog Portal

www.blog.rdm.com



[/reichle-&-de-massari-ag](https://www.linkedin.com/company/reichle-&-de-massari-ag)



[/reichledemassari](https://www.instagram.com/reichledemassari)



[@reichledemassari](https://www.facebook.com/reichledemassari)



[/ReichleDeMassariAG](https://www.youtube.com/ReichleDeMassariAG)



[@reichle_massari](https://twitter.com/reichle_massari)

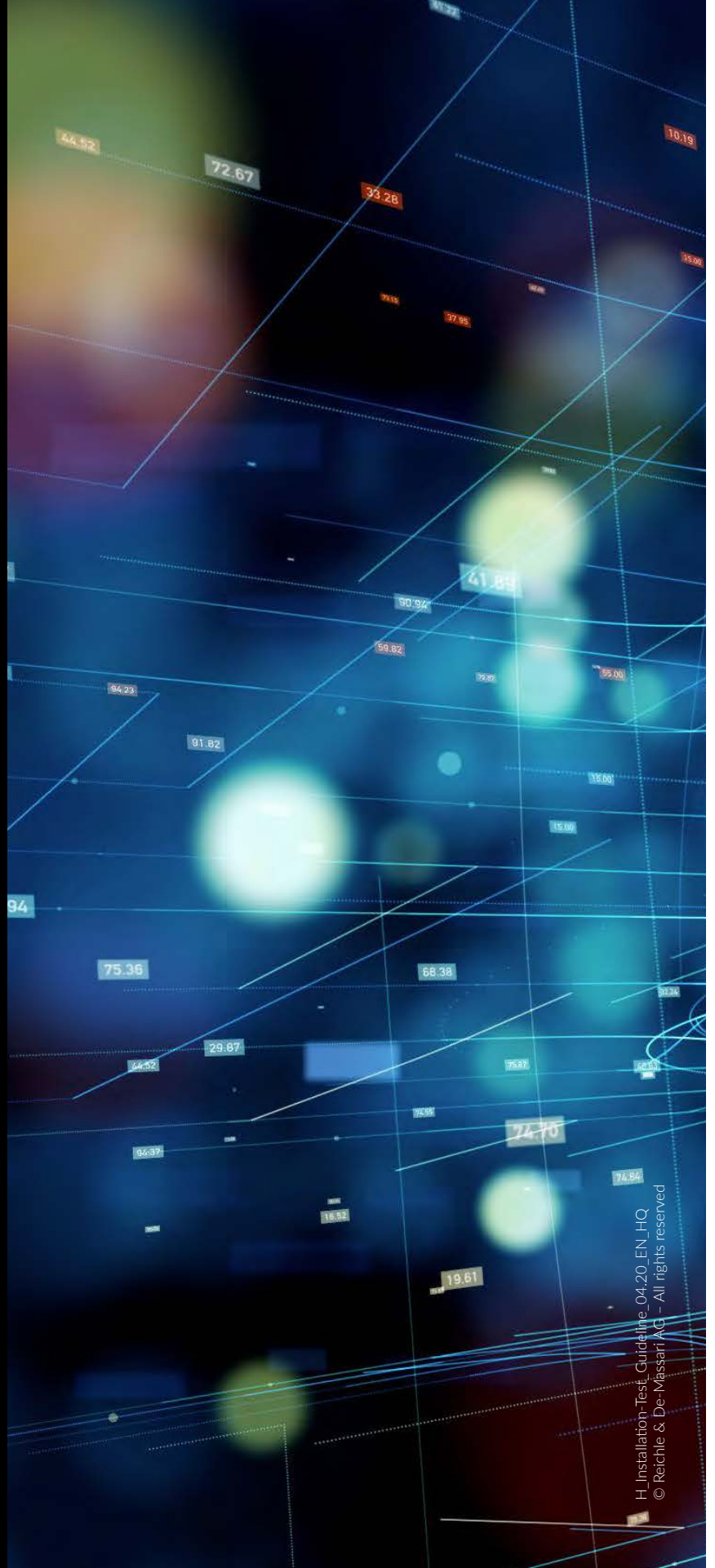

H:\Installation-Test_Guideline_04.20_EN_HQ
© Reichle & De-Massari AG – All rights reserved



We are represented by almost 3000 qualified partners worldwide.
Find your local partner at: www.rdm.com

